



# Operation and Maintenance Instructions

For EVAPCO Closed Circuit Coolers and Evaporative Condensers



**IARW** International Association of Refrigerated Warehouses



**AHRP** Air-Conditioning, Heating, and Refrigeration Institute

## Table of Contents

<b>3</b>	<b>Introduction</b>	<b>24</b>	<b>Cold Weather Operation</b>
<b>3</b>	<b>Safety Precautions</b>	24	Unit Layout
<b>3</b>	<b>Terminology</b>	24	Freeze Protection of Recirculating Water
<b>4</b>	<b>Initial Storage and/or Idle Period Recommendations</b>	26	Freeze Protection of Closed Circuit Cooler Coils
<b>5</b>	<b>International Building Code Provision</b>	27	Unit Accessories
<b>5</b>	<b>Initial and Seasonal Start-Up Checklist</b>	27	Cold Water Basin Heaters
6	General	27	Remote Sumps
6	Initial and Seasonal Start-Up	27	Electric Water Level Control
7	Recommended Maintenance Schedule	27	Vibration Cut Out Switches
9	Seasonal Shut-Down Checklist	27	Capacity Control Methods for Cold Weather Operation
<b>10</b>	<b>Basic Closed Circuit Cooler/Condenser Sequence of Operation</b>	27	Induced Draft Unit Capacity Control
<b>11</b>	<b>Fan System</b>	28	Forced Draft Unit Capacity Control
11	Fan Motor Bearings	28	Ice Management
11	Fan Shaft Ball Bearings	28	Induced Draft Units
12	Fan Belt Adjustment	28	Forced Draft Units
13	Fan Belt Adjustment – Induced Draft	<b>29</b>	<b>Troubleshooting</b>
14	Fan Belt Adjustment – Forced Draft	<b>32</b>	<b>Replacement Parts</b>
14	Gear Drives	33	Part Identification Drawings
14	Air Inlet	33	ATWB/eco-ATWB 3' Wide Units
14	Coil Inlet	34	ATC-E/ATWB/eco-ATWB 4'x4' & 4'x6' Wide Units
15	Fan System – Capacity Control	35	ATC-E/ATWB/eco-ATWB 4'x9' & 4'x12' Wide Units
15	Fan Motor Cycling	36	ATC-E/ATWB/eco-ATC-A/eco-ATWB 7' Wide Units
15	Sequence of Operation for Fan Motor Cycling	37	ATC-E/ATWB/eco-ATC-A/eco-ATWB 8' & 8.5' Wide Units
15	Variable Frequency Drives	38	eco-ATC-H/eco-ATWB-H 8.5' Wide Units
15	Sequence of Operations / Guidelines for Multi-fan Units with a VFD during Peak Load	39	eco-ATWB-E 8.5' Wide Units
16	Two-Speed Motors	40	ATC-E/ATWB/eco-ATC-A/eco-ATWB 10' & 12' Wide Units
16	Sequence of Operation for Two Fan Units with Two Speed Motors during Peak Load	41	eco-ATC-H/eco-ATWB-H 10' & 12' Wide Units
<b>17</b>	<b>Recirculated Water System – Routine Maintenance</b>	42	eco-ATWB-E 10' & 12' Wide Units
17	Suction Strainer in Cold Water Basin	43	ESW4 8.5' Wide Units
18	Cold Water Basin	44	ESW4 12' Wide Units
18	Operating Level of Water in Cold Water Basin	45	ESW4 14' Wide Units
19	Water Make Up Valve	46	LSC-E/LSWE/eco-LSWE 4' Wide Units
19	Pressurized Water Distribution Systems	47	LSC-E/LSWE/eco-LSWE 5' Wide Units
20	Bleed-Off Valve	48	LSC-E/LSWE/eco-LSWE 8' Wide Units (Single Side Fans)
20	Pump (When Supplied)	49	LSC-E/LSWE/eco-LSWE 10' Wide Units
<b>21</b>	<b>Water Treatment and Water Chemistry</b>	50	LRC/LRWB/eco-LRWB 3' Wide Units
21	Bleed or Blowdown	51	LRC/LRWB/eco-LRWB 5' Wide Units
21	Galvanized Steel – Passivation	52	LRC/LRWB/eco-LRWB 8' Wide Units
22	Water Chemistry Parameters	53	PMC-E/eco-PMC 5' Wide Units
22	Control of Biological Contamination	54	PMC-E/eco-PMC 10' and 12' Wide Units
23	Gray Water and Reclaimed Water	55	PHC-S/PHC-L 12' Wide Single Side Air Inlet Units
23	Air Contamination	56	PHC-D 12' and 14' Wide Two Side Air Inlet Units

## Introduction

Congratulations on the purchase of your EVAPCO evaporative cooling unit. EVAPCO equipment is constructed of the highest quality materials and designed to provide years of reliable service when properly maintained.

Thoroughly clean road salt, dirt and debris from unit immediately after delivery. Residue left on product surfaces can cause damage that is not covered by any warranty.

Evaporative cooling equipment is often remotely located and periodic maintenance checks are often overlooked. It is important to establish a regular maintenance program and be sure that the program is followed. This bulletin should be used as a guide to establish a program. A clean and properly serviced unit will provide a long service life and operate at peak efficiency.

This bulletin includes recommended maintenance services for unit start up, unit operation and unit shutdown and the frequency of each. Please note: the recommendations of frequency of service are minimums. Services should be performed more often when operating conditions necessitate.

Become familiar with your evaporative cooling equipment. Refer to the isometric drawings located on pages 31-52 for information on the arrangement of components in your equipment.

If you should require any additional information about the operation or maintenance of this equipment, contact your local EVAPCO sales representative. You may also visit [www.evapco.com](http://www.evapco.com) for more information.

## Safety Precautions

Qualified personnel should use proper care, procedures and tools when operating, maintaining or repairing this equipment in order to prevent personal injury and/or property damage. The warnings listed below are to be used as guidelines only.



**This equipment should never be operated without fan screens and access doors properly secured and in place.**



**A lockable disconnect switch should be located within sight of the unit for each fan motor associated with this equipment. Before performing any type of service or inspection of the unit make certain that all power has been disconnected and locked in the "OFF" position.**



**The top horizontal surface of any unit is not intended to be used as a working platform. No routine service work is required from this area.**



**Building water systems receive potable and non-potable water from either a public or private entity for their water supply. This water supply for the building water system can contain various waterborne pathogens, including Legionella bacteria, which can cause or contribute to various illnesses if aspirated, ingested or inhaled. Since evaporative cooling equipment uses the same building water, there is some potential that these pathogens might propagate in the equipment. Therefore, careful consideration should be undertaken with respect to equipment location and the implementation of effective water management, inspection and cleaning protocols. (See Control of Biological Contaminants in these Operation and Maintenance Instructions.)**

## Terminology

Throughout this manual, the terms "Induced Draft" and "Forced Draft" are used. Below is a list of EVAPCO Closed Circuit Cooler and Condenser products offerings and associated terminology.

**Induced Draft** equipment includes the following EVAPCO Product Models:

- **ESW4 - Closed Circuit Cooler**
- **AT Product Lines**
  - ATWB - Closed Circuit Cooler
  - ATC-E - Evaporative Condenser

- eco-ATWB - Closed Circuit Cooler
- eco-ATWB-E - Wet/Dry Closed Circuit Cooler
- eco-ATWB-H - Wet/Dry Closed Circuit Cooler
- eco-ATC-A - Wet/Dry Evaporative Condenser
- eco-ATC-H Wet/Dry Evaporative Condenser

#### ■ PHC - Parallel Hybrid Evaporative Condenser

**Forced Draft** equipment includes the following EVAPCO Product Models:

#### ■ LR Product Lines

- LRWB - Closed Circuit Cooler
- LRC - Evaporative Condenser
- eco-LRWB - Wet/Dry Closed Circuit Cooler

#### ■ LS Product Lines

- LSWE - Closed Circuit Cooler
- LSC-E - Evaporative Condenser
- eco-LSWE - Wet/Dry Closed Circuit Cooler

#### ■ PM Product lines

- PMC-E - Evaporative Condenser
- PMC-Q - Evaporative Condenser
- eco-PMC - Wet/Dry Evaporative Condenser

## Initial Storage and/or Idle Period Recommendations

If the unit will sit for idle periods of time it is recommended that the following be performed in addition to all component manufacturers recommended maintenance instructions.

- The fan/motor/pump bearings and motor bearings need to be turned by hand at least once a month. This can be accomplished by tagging and locking out the unit's disconnect, grasping the fan assembly (or removing the pump motor fan guard), and rotating it several turns.
- If unit sits longer than a few weeks, run gear reducer (if equipped) for 5 minutes weekly.
- If unit sits longer than 3 weeks, completely fill gear reducer with oil. Drain to normal level prior to running.
- If unit sits longer than one month, insulation test motor windings semi-annually.
- If fan motor sits idle for at least 24 hours while the spray pumps are energized distributing water over the coil, motor space heaters (if equipped) should be energized. Alternatively, fan motors may be energized for 10 minutes, twice daily, to drive any moisture condensation out of the motor windings.
- If coil sits longer than one month, nitrogen charge the coil.
- Energize fan motors space heaters.

## International Building Code Provisions

The International Building Code (IBC) is a comprehensive set of regulations addressing the structural design and installation requirements for building systems – including HVAC and industrial refrigeration equipment. The code provisions require that evaporative cooling equipment and all other components permanently installed on a structure must meet the same seismic design criteria as the building.

All items attached to EVAPCO Closed Circuit Coolers or Evaporative Condensers must be independently reviewed and isolated to meet applicable wind and seismic loads. This includes piping, ductwork, conduit, and electrical connections. These items must be flexibly attached to the EVAPCO unit so as not to transmit additional loads to the equipment as a result of seismic or wind forces.

## Initial and Seasonal Startup Checklist

### General

- 1. Verify that the overall installation reflects the requirements of the installation guidelines found in EVAPCO Bulletin 311 – Equipment Layout Manual available at [www.evapco.com](http://www.evapco.com).
- 2. Fan motor space heaters - To prevent any moisture buildup in the windings and bearings, space heaters are provided as standard on every fan motor. These should be wired prior to operation.
- 3. For multi-speed fan motors, verify that 30 seconds or greater time delays are provided for speed changes when switching from high to low speed. Also check to see if interlocks are provided to prevent simultaneously energizing high and low speed, and confirm both speeds operate in the same direction.
- 4. Verify all safety interlocks work properly.
- 5. For units operating with a variable frequency drive, make certain that minimum speed requirements have been set. Check with VFD manufacturer for recommended minimum speeds. See “Fan System - Capacity Control” section for more information, and recommendations on locking out resonance frequencies.
- 6. Verify that a water treatment plan has been implemented including passivation of galvanized steel units. See “Water Treatment” section for more details.
- 7. If the unit is going to sit idle for an extended period of time, follow all manufacturers’ fan motor and pump instructions for long term storage. Plastic sheets or tarps should never be used to protect a unit during storage. This practice can trap heat inside the unit, and could potentially cause damage to plastic components. See your local EVAPCO representative for additional information on unit storage.

**BEFORE BEGINNING ANY MAINTENANCE, BE CERTAIN THAT THE POWER IS TURNED OFF AND THE UNIT IS PROPERLY LOCKED AND TAGGED OUT!**

### Initial and Seasonal Start-Up

- 1. Clean and remove any debris, such as leaves and dirt from the air inlets.
- 2. Flush the cold water basin (with the strainer screens in place) to remove any sediment or dirt.
- 3. Remove the strainer screen, clean **and reinstall**.
- 4. Check mechanical float valve to see if it operates freely.
- 5. Inspect water distribution system nozzles and clean as required. Check for proper orientation.  
*(This is not required at initial start-up. The nozzles are clean and set at the factory).*
- 6. Check to ensure drift eliminators are securely in place and in the proper orientation.
- 7. Adjust fan belt tension as required. See “Fan Belt Adjustment” section.
- 8. Lubricate fan shaft bearings prior to seasonal start-up.

- 9. Turn the fan(s) and pumps by hand to insure it turns freely without obstructions.
- 10. Visually inspect the fan blades. Blade clearance should be approximately 3/8" (10mm) (1/4" [6mm] minimum) from tip of blade to the fan cowl. The fan blades should be securely tightened to the fan hub.
- 11. If any stagnant water remains in the system including "dead legs" in the piping, the unit must be disinfected prior to the fans being energized. Please refer to ASHRAE Guideline 12 and CTI Guideline WTP-148 for more information.
- 12. Manually fill the cold water basin up to the overflow connection.
- 13. For closed circuit coolers, fill the heat exchanger coil with the specified fluid and "burp" air from the system before pressurizing, using vents on coil inlets. Do not do this for evaporative condensers.

**NOTE:** Closed circuit coolers should only be used on sealed, pressurized systems. Continual aeration of the water in an open system can cause corrosion inside the tubes of the cooler leading to premature failure.

For closed circuit coolers with optional controls, see controls O&M for proper start up procedure.

**After the unit has been energized, check the following:**

- 1. Adjust mechanical float valve as required to the proper water level.
- 2. Unit basin should be filled to the proper operating level. See "Recirculating Water System Operating Levels" section for more details.
- 3. Verify fan(s) is rotating in proper direction.
- 4. Start the spray water pump(s) and check for proper rotation as indicated by the arrow on the front cover.
- 5. Measure voltage and current on all three power leads of pump and fan motor. The current should not exceed the motor nameplate full load amp rating taking the service factor into account.
- 6. Consult your qualified water treatment company to fine tune the minimum bleed necessary, see "Water Treatment and Water Chemistry" section.
- 7. See fan and pump motor manufacturer maintenance and long term storage instructions for more detailed information. The motors should be lubricated and serviced in accordance with manufacturer's instructions.
- 8. All new evaporative cooling equipment and associated piping should be precleaned and flushed to remove grease, oil, dirt, debris and other suspended solids prior to operation. Any precleaning chemistry should be compatible with the cooling equipment's materials of construction. Alkaline formulations should be avoided for systems which include galvanized materials of construction.

Closed hydronic systems connected to either a closed-circuit cooler or dry cooler should be precleaned and flushed to remove debris, grease, flash rust, oil, and other suspended solids prior to operation. EVAPCO recommends the use of inhibitor chemistry or inhibited glycol to minimize corrosion and scale during normal operation. EVAPCO recommends a minimum of 25% inhibited glycol to minimize corrosion.

## Recommended Minimum Maintenance Schedule

PROCEDURE	FREQUENCY
1. Clean pan strainer	Monthly or as needed
2. Clean and flush pan**	Quarterly or as needed
3. Check bleed-off valve to make sure it is operative	Monthly
4. Check operating level in pan and adjust float valve if necessary	Monthly
5. Check water distribution system and spray pattern	Monthly
6. Check drift eliminators	Quarterly
7. Check the fan blades for cracks, missing balancing weights loose weight port caps and open drain holes (Super Low Sound Fans) and vibrations	Quarterly
8. Check sheaves, bushings, fan shafts and fan hubs for corrosion. Scrape and coat with ZRC	Annually
9. Inspect lubrication lines to bearings	Quarterly
10. Lubricate fan shaft bearings*	Every 1000 hours of operation (or every three months)
11. Check belt tension and adjust	Monthly
12. Sliding motor base – Inspect and grease	Annually or as needed
13. Check fan screens, inlet louvers and fans. Remove any dirt or debris	Monthly or as needed
14. Inspect and clean protective finish - Galvanized: scrape and coat with ZRC - Stainless: clean and polish with a stainless steel cleaner.	Annually
15. Check water quality for biological contamination. Clean unit as needed and contact a water treatment company for recommended water treatment program**	Regularly

### OPTIONAL ACCESSORIES:

1. Gear Reducer – Check oil level with unit stopped	24 hours after start-up & monthly
2. Gear Reducer/Piping – Do visual inspection for oil leaks, auditory inspection for unusual noises and vibrations	Monthly
3. Gear Reducer – Replace oil	Semi-annually
4. Oil Pump – Do visual inspection for leaks and proper wiring	Monthly
5. Gear Reducer/Coupling – Check alignment of the system	24 hours after start-up & monthly
6. Coupling/Shaft – Inspect flex elements and hardware for tightness, proper torque & crack/deterioration	Monthly
7. Heater Controller – Inspect controller and clean probe ends	Quarterly
8. Heater – Inspect junction box for loose wiring and moisture	One month after start-up and semi-annually

\* See maintenance manual for start-up instructions and lubrication recommendations.

\*\* Cooling Towers must be cleaned on a regular basis to prevent the growth of bacteria including Legionella Pneumophila.

## Recommended Maintenance Schedule (continued)

### OPTIONAL ACCESSORIES:

9. Heater – Inspect elements for scale buildup	Quarterly
10. Electronic Water Level Controller – Inspect junction box for loose wiring and moisture	Semiannually
11. Electronic Water Level Controller – Clean probe ends of scale build-up	Quarterly or as needed
12. Electronic Water Level Controller – Clean inside the standpipe	Annually
13. Solenoid Makeup Valve – Inspect and clean valve and strainer of debris	As needed
14. Vibration Switch (mechanical) – Inspect enclosure for loose wiring and moisture	One month after startup and monthly
15. Vibration Switch – Adjust the sensitivity	During startup and annually
16. Sump Sweeper Piping – Inspect and clean piping of debris	Semiannually
17. Water Level Indicator – Inspect and clean	Annually
18. SUN Solar Panels – Inspect for damage and clean with hose and soft brush	Semiannually

### DURING IDLE PERIODS:

Idle Period	Recommended Action	Frequency
Two or More Days	Energize motor space heaters - or run motors for 10 minutes	Twice daily
Few Weeks	Run gear reducer for 5 minutes	Weekly
Several Weeks	Completely fill gear reducer with oil. Drain to normal level prior to running.	Once
One Month or Longer	Rotate motor shaft/fan 10 turns	Bi-weekly
	Megger test motor windings	Semi-annually



## Seasonal Shutdown Checklist

---

When the system is to be shut down for an extended period of time, the following services should be performed.

- 1. The evaporative cooling unit cold water basin should be drained
- 2. The cold water basin should be flushed and cleaned with the suction strainer screens in place.
- 3. The suction strainer screens should be cleaned and re-installed.
- 4. The cold water basin drain should be left open.
- 5. The fan shaft bearings and motor base adjusting screws should be lubricated. This should also be performed if the unit is going to sit idle prior to initial start-up.
- 6. The makeup water supply, overflow and drain lines, as well as the recirculating pump and pump piping up to the overflow level must be heat traced and insulated to account for any residual water.
- 7. The finish of the unit should be inspected. Clean and refinish as required.
- 8. The fan, motor and pump bearings need to be turned at least once a month by hand. This can be accomplished by making sure the unit's disconnect is tagged and locked out, and grasping the fan assembly, rotating it several turns.
- 9. Energize fan motor space heaters.
- 10. Closed Circuit Coolers only - If the recommended minimum fluid flows through the heat transfer coil cannot be maintained, and an anti-freeze solution is not in the coil, the coil must be drained immediately whenever the system pumps are shut down or flow stops during freezing conditions. This is accomplished by having automatic drain valves and air vents in the piping to and from the cooler. Care must be taken to ensure that the piping is adequately insulated and sized to allow the water to flow quickly from the coil. This method of protection should be used only in emergency situations and is neither a practical nor recommended method of freeze protection. Coils should not be drained for an extended period of time, as internal corrosion may occur. See Cold Weather Operation section of this document for more details.

**See fan and pump manufacturer maintenance and long term storage instructions for more detailed instructions.**

# Basic Closed Circuit Cooler/Condenser Sequence of Operation for Wet or Evaporative Mode

## System Off / No Load

The system pumps and fans are off. If the basin is full of water a minimum basin water temperature of 40°F (4°C) must be maintained to prevent freezing. This can be accomplished with the use of optional basin heaters. See the “Cold Weather Operation” section of this bulletin for more details on cold weather operation and maintenance.

## System/Condensing Temperature Rises

The recirculation pump turns on. The unit will provide approximately 10% cooling capacity with only the pump running. If the unit has positive closure dampers they should be fully opened before the pumps turn on.

If the system temperature continues to rise, the unit fan is cycled on. For a variable speed controller, the fans are turned on to minimum speed. See the “Fan System – Capacity Control” section of this bulletin for more details on fan speed control options. If the system temperature continues to rise, then the fan speed is increased as required, up to full speed.

**NOTE:** *During sub-freezing weather the minimum recommended speed for variable speed controllers is 50%. ALL FANS IN OPERATING CELLS OF MULTIPLE CELL UNITS MUST BE CONTROLLED TOGETHER TO PREVENT ICING ON THE FANS.*

## System/Condensing Temperature Stabilizes

Control the leaving fluid temperature (closed circuit coolers) or condensing temperature (evaporative condensers) by modulating the fan speeds with variable speed drives or by cycling fans on and off with single or two-speed drives.

## System/Condensing Temperature Drops

Decrease the fan speed, as required.

## System Off / No Load

The system pump turns off. The starter interlock will energize any optional basin heaters in cold weather.

The recirculation pump should not be used as a means of capacity control, and should not be cycled frequently. Excessive cycling can lead to scale build-up, and reduce wet and dry performance.

## Dry Operation

During colder winter months it is possible to turn off the spray pump, drain the cold water basin, and just cycle the fans. Be sure to leave the basin drain open during this time to prevent collection of rain water, snow, etc. If the unit has positive closure dampers they should be fully opened before the fans turn on. If dry operation will be used on a centrifugal fan, forced draft unit, be sure to verify that the motor and drives have been properly sized to handle the reduction in static pressure experienced when the spray water is turned off.

**NOTE:** *Minimum control point for process fluid should never be lower than 42° F (6°C).*

**NOTE:** *When a unit is provided with a discharge damper assembly, the control sequence should cycle the dampers open and closed once a day regardless of capacity requirements to prevent the assembly from seizing. The fan motor should be shut off whenever the dampers are closed.*

**NOTE:** *ESW4/A or PHC product lines should not operate dry.*

**NOTE:** *The eco-ATW/eco-ATWE sequence of operation is unique and is explained in detail in the Sage<sup>2</sup>, Sage<sup>3</sup> Panel Control Manual.*

# Fan System

The fan systems of both centrifugal and axial driven units are rugged; however, the fan system must be checked regularly and lubricated at the proper intervals. The following maintenance schedule is recommended.

## Fan Motor Bearings

EVAPCO evaporative cooling units use either a totally enclosed air over (TEAO) or a totally enclosed fan cooled (TEFC) fan motor. These motors are built to "Cooling Tower Duty" specifications. They are supplied with permanently lubricated bearings and special moisture protection on the bearings, shaft and windings. After extended shutdowns, the motor should be checked with an insulation tester prior to restarting the motor.

## Fan Shaft Ball Bearings

For induced draft units, lubricate the fan shaft bearings every 1,000 hours of operation or every three months. For forced draft units, lubricate the fan shaft bearings every 2,000 hours of operation or every six months. Use any of the following synthetic waterproof, polyurea inhibited greases which are suitable for operation between -20°F (-29°C) and 350°F (177°C). (For colder operating temperatures, contact the factory).

Mobil – Polyrex EM

Chevron - SRI

Timken Pillowblock Grease

**Feed grease slowly into the bearings or the seals may be damaged. A hand grease gun is recommended for this process. When introducing new grease, all grease should be purged from the bearings.**

Most EVAPCO units are supplied with extended grease lines to allow easy lubrication of the fan shaft bearings as shown in Table 1.

Unit Description	Location of Lube Line Fittings
Induced Draft Units: 3', 4', 8', 8.5', 17' wide	Located just beside the fan casing access door
Induced Draft Units: 10', 12', 14', 24', 28' wide	Located inside the fan casing access door
Forced Draft Units	Located on the bearing support or on the side of the unit
PHC Units	Located inside access door at bottom of casing/ above the field seam

**Table 1** – Location of Grease Lube Line Fittings for Belt Driven Units

## Fan Belt Adjustment (Direct drive units do not require any adjustment)

The fan belt tension should be checked at start up and again after the first 24 hours of operation to correct for any initial stretch. To properly adjust the belt tension, position the fan motor so that the fan belt will deflect approximately 3/8" (10mm) when moderate pressure is applied midway between the sheaves. Figure 1 and Figure 2 show two ways to measure this deflection. Belt tension should be checked on a monthly basis. A properly tensioned belt will not "chirp" or "squeal" when the fan motor is started.

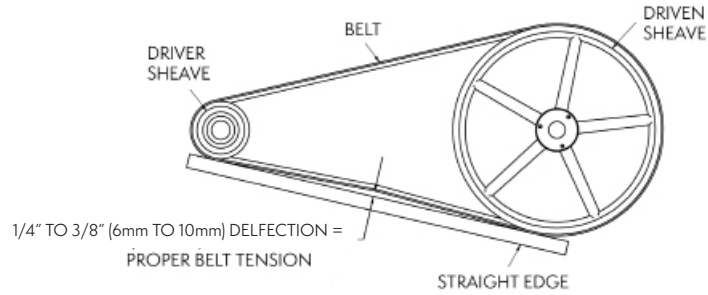


Figure 1 – Method 1

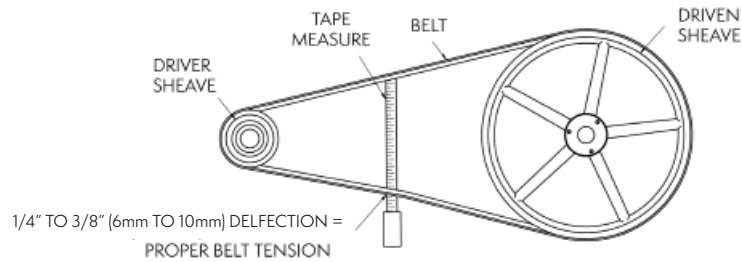
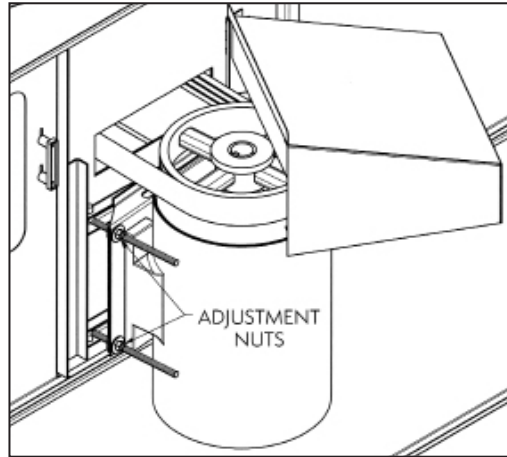


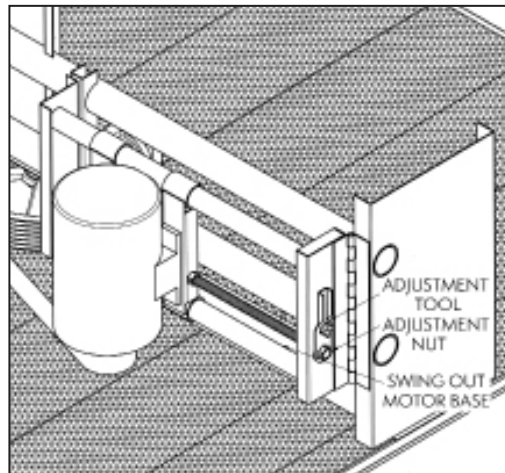
Figure 2 – Method 2

**Induced Draft** – On induced draft belt driven units provided with externally mounted motors, see Figure 3.

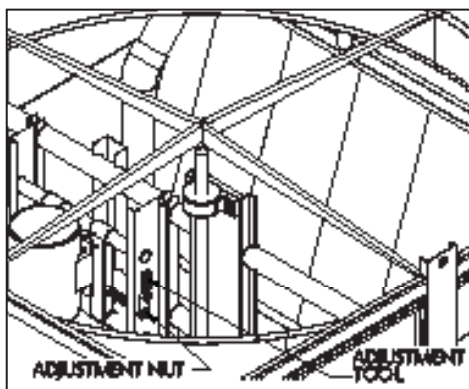


**Figure 3** – Externally Mounted Motor, Induced Draft

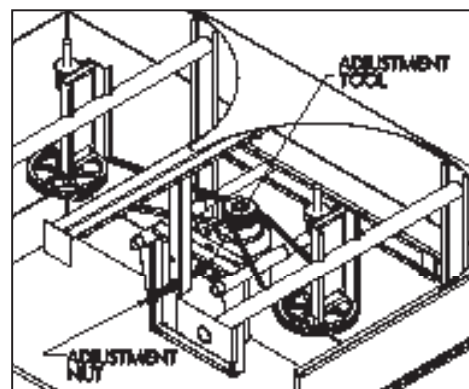
On induced draft belt driven units with internally mounted motors (10, 12, 14, 20, 24 and 28 foot wide units). PHC-S, L and D Units, a motor adjustment tool is provided on the adjustment nut. To use, place the hex end over the adjustment nut and tension the belt by turning the nut counterclockwise. When the belts are properly tensioned, tighten the lock nut.



**Figure 4** – Internally Mounted Motor, Induced Draft

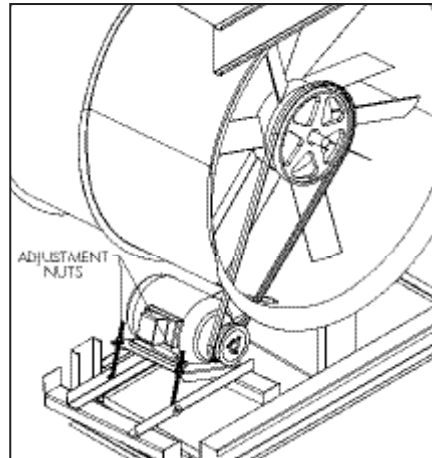


**Figure 5** – Internally Mounted Motor, PHC-D Unit

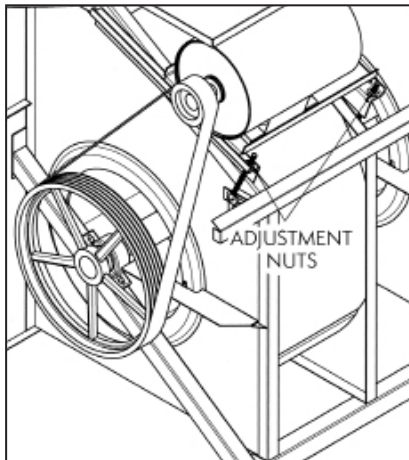


**Figure 6** – Internally Mounted Motor, PHC-S & L Tandem Fan Units

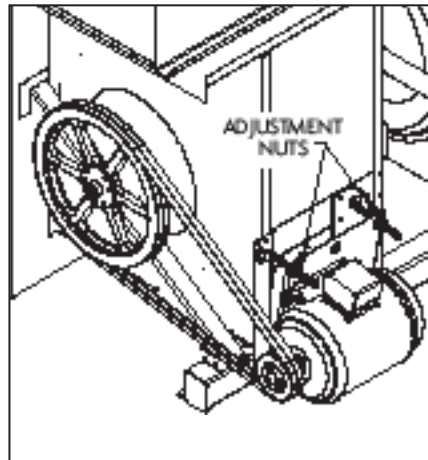
**Forced Draft** – LS and PM Style forced draft units, both J-type adjustment bolts on the adjustable motor base should have an equal amount of exposed thread for proper sheave and belt alignment.



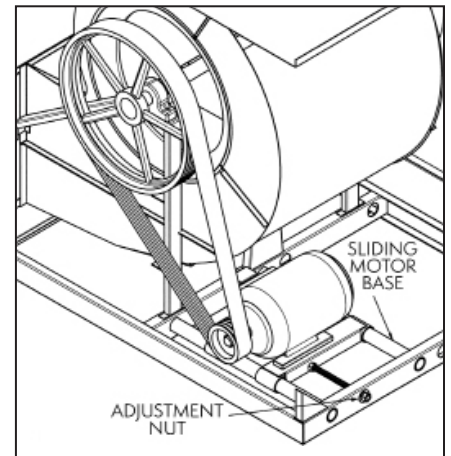
**Figure 7** – PM Style Motor Adjustment



**Figure 8a** – Externally Mounted Motor, Large LS, 8X & 3M Units



**Figure 8b** – Externally Mounted Motor, Small LS, 4X & 5X Units



**Figure 9** – LR Motor Adjustment

## **Gear Drives**

Induced draft units with gear drive systems require special maintenance. Please refer to the gear manufacturers recommended maintenance instructions. These will be enclosed and shipped with the unit.

## **Air Inlet**

Inspect the air inlet louvers (induced draft units) or fan screens (forced draft units) monthly to remove any paper, leaves or other debris that may be blocking airflow into the unit.

## **Coil Inlet**

Inspect the top coil, air inlet and spray section on all PHC units monthly.

## Fan System — Capacity Control

There are several methods for capacity control of the evaporative cooling unit. Methods include: Fan motor cycling, the use of two speed motors, and the use of variable frequency drives (VFD's).

Note: for the eco-ATW with Sage<sup>2</sup> and eco-ATWE with Sage<sup>3</sup> consult the manual.

### Fan Motor Cycling

Fan Motor Cycling requires the use of a single stage thermostat which senses the fluid temperature (closed circuit coolers) or condensing temperature (evaporative condensers). The contacts of the thermostat are wired in series with the fan motor's starter holding coil. For individual fan motor cyclings interlock fan motors before fan start to prevent issues with reversing idle fans.

### Sequence of Operation for Fan Motor Cycling

Fan Motor Cycling is often found to be inadequate where the load has a wide fluctuation. In this method, there are only two stable levels of performance: 100% of capacity when the fan is on, and approximately 10% of capacity when the fan is off. Please note that rapid cycling of the fan motors can cause the fan motor to overheat. Controls should be set to only allow a maximum of six start/stop cycles per hour. The recirculation pump may not be used as a means of capacity control and should not be cycled frequently. Excessive cycling can lead to scale build-up, resulting in reduced wet and dry performance.

### Variable Frequency Drives

The use of a variable frequency drive (VFD) provides the most precise method of capacity control. A VFD is a device that converts a fixed AC voltage and frequency into an adjustable AC voltage and frequency used to control the speed of an AC motor. By adjusting the voltage and frequency, the AC induction motor can operate at many different speeds.

The use of VFD technology can benefit the life of the mechanical components with fewer and smoother motor starts and built-in motor diagnostics. VFD technology has particular benefit on evaporative cooling units operating in cold climates where airflow can be modulated to minimize icing and reversed at low speed for de-icing cycles. Applications using a VFD for capacity control must also use an inverter capable motor built in compliance with NEMA standard MG-1.

**NOTE:** *Variable frequency drives (VFD) should not be used on pump motors. The pumps are designed to be operated at full speed and are not intended to be used as capacity control.*

The type of motor, manufacturer of the VFD, motor lead lengths (between the motor and the VFD), conduit runs and grounding can dramatically affect the response and life of the motor. Select a high quality VFD that is compatible with the fan motor(s) in the EVAPCO unit(s). Many variables in the VFD configuration and installation can affect motor and VFD performance. Two particularly important parameters to consider when choosing and installing a VFD are switching frequency and the distance between the motor and VFD often referred to as lead length. Consult the VFD manufacturer's recommendations for proper installation and configuration. The motor lead length restrictions can vary with the vendor. Regardless of motor supplier, minimizing lead length between the motor and drive is good practice.

### VFD Lockout Notification

#### Sequence of Operations / Guidelines for Multi-fan Units with a VFD during Peak Load

For eco-ATWE, see Sage<sup>2</sup>/Sage<sup>3</sup> control Panel O&M

1. Both fan motors off – Pump running on one cell.
2. Both fan motors off – Pump running on both cells.
3. Both VFDs turn on at the manufacturer's recommended minimum operating speed (25%) – Pump running on both cells.
4. Both VFDs speed up uniformly (they should be synchronized on start-up) – Pump running on both cells.
5. Both VFDs are on full speed – Pump running on both cells.

**NOTE:** *The VFDs need to have a preset shutoff to prevent water temperatures from becoming too cold and to prevent the drive from trying to turn the fan at near zero speed. Operating below 25% of motor speed achieves very little return in fan energy savings and capacity control. Check with your VFD supplier if operating below 25% is possible.*

## Variable Frequency Drive Lock-out Notification



**Qualified personnel should use proper care, procedures and tools when maintaining the Fan/Drive System in order to prevent personal injury and/or property damage.**



### **Identify and Lock-out Harmful Resonant Frequencies**

A Variable Frequency Drive (VFD) fan system, unlike traditional fixed-speed systems, is designed to operate between 25% (15Hz) and 100% (60Hz) speeds, which creates an opportunity for operation where resonant frequencies exist. Sustained operation at resonant frequencies may lead to excessive vibration, fatigue of structural components, and/or drive system noise and failure. Owners and operators must anticipate the existence of resonant frequencies and lock out frequencies during start-up and commissioning in order to prevent drive system operational problems and structural damage. As a part of the normal start-up and commission processes, resonant frequencies should be identified and locked-out in the VFD's software.

The unit's supporting structure, external piping, and accessories contribute to the overall harmonic make-up and stiffness of the system. The choice of VFD will also have a significant influence on how the system behaves. Consequently, not all resonant frequencies can be determined in advance at the manufacturer's factory during final inspection and testing. Relevant resonant frequencies (if they occur) can only be identified accurately after the unit installation in the system.

To check for resonant frequencies in the field, a run-up and run-down test must be performed. Additionally, VFD carrier frequencies should be adjusted to best align the VFD with the electrical system. Refer to your drive's start-up procedures for additional information and instruction.

The procedure of checking for resonant frequencies requires stepping through the VFD's operating range at (2) Hz intervals from the lowest operating frequency to full speed. At each step, pause long enough for the fan to reach steady-state. Note changes in unit vibration during this time. Repeat from full speed to minimum speed. Should vibration-inducing frequencies exist, the run-up and run-down test will isolate the resonant frequencies which then must then be locked-out in the VFD programming.

For more details on the use of variable frequency drives, please download a copy of EVAPCO's Engineering Bulletin 39 from [evapco.com](http://evapco.com).

## Two-Speed Motors

The use of a two-speed motor provides an additional step of capacity control when used with the fan cycling method. The low speed of the motor will provide approximately 60% of full speed capacity.

Two-speed capacity control systems require not only a two-speed motor, but also a two-stage thermostat and the proper two-speed motor starter. The most common two-speed motor is a single winding type. This is also known as a consequent pole design. Two-speed two-winding motors are also available. All multi-speed motors used in evaporative cooling units should be variable torque design.

**NOTE:** *When two-speed motors are to be used, the motor starter controls must be equipped with a decelerating time delay relay. The time delay should be a minimum of 30 seconds when switching from high speed to low speed.*

### **Sequence of Operation for Two Cell Units with Two Speed Motors during Peak Load**

For eco-ATWE, see Sage<sup>2</sup>/Sage<sup>3</sup> control Panel O&M

1. Both fan motors off – Pump running on one cell.
2. Both fan motors off – Pump running on both cells.
3. One fan motor on low speed, one fan motor off – Pump running on both cells.
4. Both fan motors on low speed – Pump running on both cells.
5. One fan motor on high speed, one fan motor on low speed – Pump running on both cells.
6. Both fan motors on full speed – Pump running on both cells.



# Recirculated Water System — Routine Maintenance

## Suction Strainer in Cold Water Basin

The pan strainer as shown in Figures 10 through 14 should be removed and cleaned monthly or as often as necessary. The suction strainer is the first line of defense in keeping debris out of the system. Make certain that the strainer is properly located over the pump suction, alongside the anti-vortexing hood.

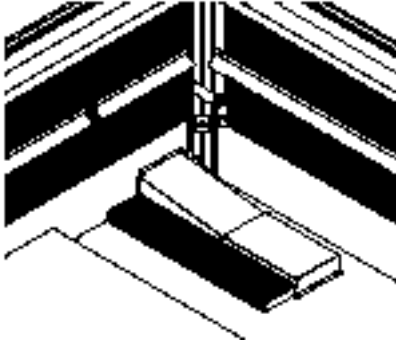


Figure 10 – ATC/W Single Strainer Assembly

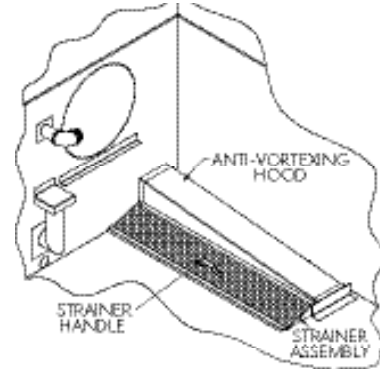


Figure 11 – LSWE/LSC-E/PMC-E Strainer Assembly

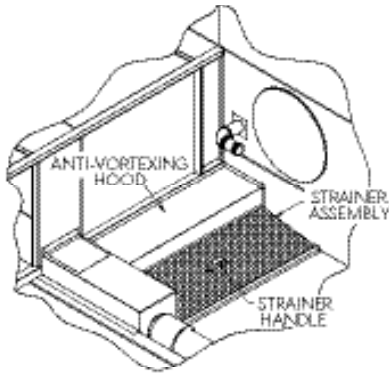


Figure 12 – LRWB/LRC Strainer Assembly

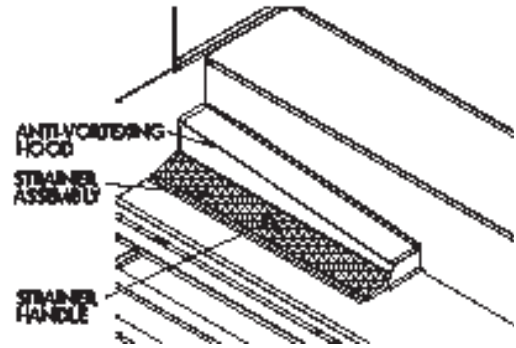


Figure 13 – PHC-S&L Strainer Assembly

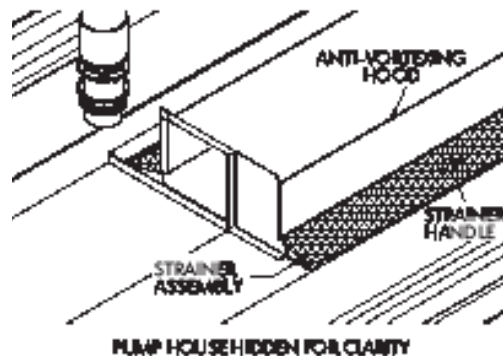


Figure 14 – PHC-D Strainer Assembly

## Cold Water Basin

The cold water basin should be flushed out quarterly, and checked monthly or more often if necessary, to remove any accumulation of dirt or sediment which normally collects in the basin. Sediment can become corrosive and cause deterioration of basin materials. When flushing the basin, it is important to keep the suction strainers in place to prevent any sediment from entering the system. After the basin has been cleaned, the strainers should be removed and cleaned before refilling the basin with fresh water.

## Operating Level of Water in Cold Water Basin

The operating level should be checked monthly to make sure the water level is correct. Refer to Table 3 for unit specific levels.

Evaporative Condenser Model Number	Closed Circuit Cooler Footprint	Operating Water Level* (inch)	Operating Water Level* (mm)
<b>ATC-E Products</b> 50E to 165E, 170E to 3714E	<b>ATWB, eco-ATW &amp; eco-ATWE Products</b> 3' and 4' wide units** 8.5' wide to "7' wide thru 24' wide"	9" 11"	229 279
<b>eco-ATC-H</b> 8.5' Wide to 24' Wide		11"	279
<b>eco-ATC Products</b> 122A to 3846A	<b>eco-ATWB-E</b> 8.5' wide thru 24' wide	11"	279
<b>LRC Products</b> 25 to 379	<b>LRWB Products</b> 3' wide thru 8' wide units	8"	203
<b>LSC-E Products</b> 36 to 170 185 to 385 400 to 515, 800 to 1030 550 to 805, 1100 to 1610	<b>LSW Products</b> 4'x6' thru 4'x12' 5.5'x12', 5.5'x18' 8'x12', 8'x24', 10'x12', 10'x24' 8'x18', 8'x36', 10'x18', 10'x36'	11" 11" 12" 15"	279 279 305 381
<b>PMC-E, eco-PMC</b> 175E to 375E, 183 to 387 332E to 2019E, 275 to 2191		10" 14"	254 356
—	<b>ESW4 Products</b> 8.5' and 14' wide units 12' wide unit	9" 10"	229 254
<b>PHC-S, L and D Products</b> S-208 to S-1182 L-464 to L-842 D-621 to D-2050		9" 9" 10"	229 229 254

\* Measured from lowest point on basin floor.

\*\* Not available on eco-ATWE.

† Measured from the overflow.

**Table 3** - Recommended Operating Water Level

At initial start up or after the unit has been drained, the unit must be filled to the overflow level. Overflow is above the normal operating level and accommodates the volume of water normally in suspension in the water distribution system and the riser piping.

The water level should always be above the strainer. Check by running the pump with the fan motors off and observing the water level through the access door or remove the air inlet louver.

## Water Make Up Valve

A mechanical float valve assembly is provided as standard equipment on the evaporative cooling unit (unless the unit has been ordered with an optional electronic water level control package or the unit is arranged for remote sump operation). The make up valve is easily accessible from outside the unit through the access door or removable air inlet louver. The make up valve is a bronze valve connected to a float arm assembly and is activated by a large foam filled plastic float. The float is mounted on an all-thread rod held in place by wing nuts. The water level in the basin is adjusted by repositioning the float and all-thread using the wing nuts. Refer to Figure 15 for details. The bottom center of the float should be set at 1" below the middle of the overflow. At its highest point, float arm should be parallel to the water level.

The make up valve assembly should be inspected monthly and adjusted as required. The valve should be inspected annually for leakage and if necessary, the valve seat should be replaced. The make up water pressure for the mechanical valve should be maintained between 20 and 50 PSIG (138 kPa and 345 kPa).

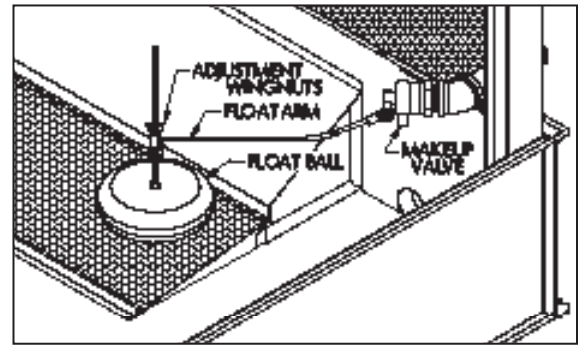


Figure 15 – Mechanical Water Make Up Valve

## Pressurized Water Distribution Systems

Check the water distribution system monthly to make sure it is operating properly. Always check the spray system with the pump on and the fans off. On forced draft models, remove one or two eliminator sections from the top of the unit and observe the operation of the water distribution system. On induced draft models, lifting handles are provided along the top layer of eliminators. Eliminators can be easily removed from the access door and the distribution system observed. The diffusers are essentially non-clogging and should seldom need cleaning or maintenance.

If the water diffusers are not functioning properly, it is a sign that the pan or system strainer has not been working properly and that foreign matter or dirt has accumulated in the water distribution pipes. The nozzles can be cleared by taking a small pointed probe and moving it rapidly back and forth in the diffuser opening.

If an extreme build-up of dirt or foreign matter occurs, remove the end cap in each branch to flush the debris from the header pipe. The branches or header can be removed for cleaning, but do so only if necessary. Check the strainer in the pan to make sure it is in good condition and positioned properly so that cavitation or air entrainment does not occur.

All Evaporative Condensers and Closed Circuit Coolers, except the ESW4 Closed Circuit Cooler, are supplied with ZMII® spray nozzles as standard. The ZMII® spray nozzles do not need to be oriented a specific way to achieve proper coil coverage. Figure 16 shows the standard orientation of the ZMII® spray nozzles.

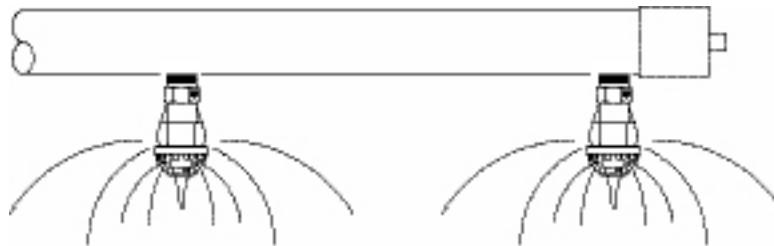
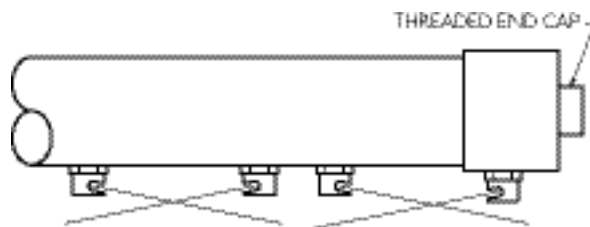
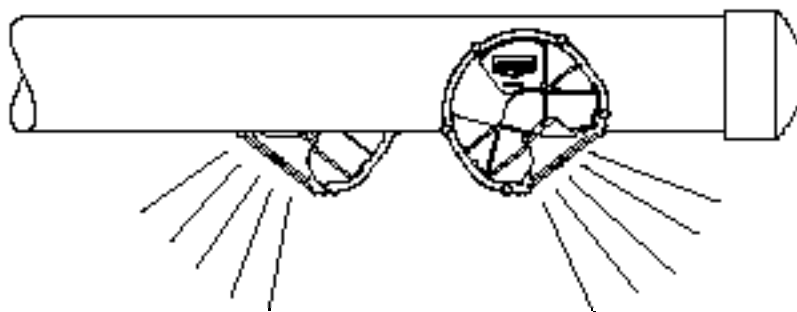


Figure 16 – ZMII® Spray Nozzle Orientation  
All Coil Products except the ESW4

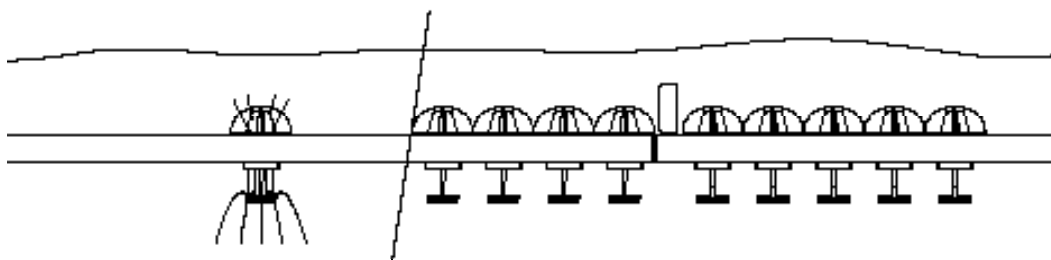
For the ESW4, wide orifice water diffusers are supplied, shown in figure 19. When inspecting and cleaning the water distribution system, always check that the orientation of the water diffusers is correct as shown in Figures 17 and 18. For EvapJet™ nozzles, make sure that the top edge of the “EVAPCO” logo is parallel to the top of the water distribution pipe.



**Figure 17** – Proper Water Diffuser Orientation (2A Nozzles)  
ESW4 Models



**Figure 18** – Proper Water Diffuser Orientation (EvapJet™)  
ESW4 Models



**Figure 19** – Gravity Fed Distribution Pan  
ESW4 Models Only

## Bleed-Off Valve

The bleed-off valve, whether factory or field installed, must be checked weekly to make sure it is functioning and set properly. Additional information can be found under “Water Treatment and Water Chemistry”.

## Pump (When Supplied)

The pump and pump motor should be lubricated and serviced in accordance with the pump manufacturer’s instructions as supplied with the unit. The recirculation pump should not be used as a means of capacity control, used with a VFD or be cycled frequently. Excessive cycling can lead to scale build-up, and reduce wet and dry performance. On 18’ long ESW4’s supplied with two pumps per cell, both pumps should be energized at the same time. One pump should not be on while the other pump is off.

The pump motor shaft and impeller should be turned by hand if the pump assembly sits idle (for a month or more).

Disconnect the power and lockout/tagout the pump disconnect. Remove the pump motor fan guard and rotate the pump fan/shaft several turns by hand. Reassemble the fan guard and return to service.

**NOTE:** For the eco-ATWE, please consult the Sage<sup>2</sup> and Sage<sup>3</sup> manual.

## Water Treatment and Water Chemistry

Proper water treatment is an essential part of the maintenance required for evaporative cooling equipment. A well designed and consistently implemented water treatment program will help to ensure efficient system operation while maximizing the equipment's service life. A qualified water treatment company should design a site specific water treatment protocol based on equipment including all metallurgies in the cooling system, location, makeup water quality, and usage.

### Bleed or Blowdown

Evaporative cooling equipment rejects heat by evaporating a portion of the recirculated water into the atmosphere as warm, saturated discharge air. As the pure water evaporates it leaves behind the impurities found in the system's makeup water and any accumulated airborne contaminants. These impurities and contaminants, which continue to recirculate in the system, must be controlled to avoid excessive concentration which can lead to corrosion, scale, or biological fouling.

Evaporative cooling equipment requires a bleed or blowdown line, located on the discharge side of the recirculating pump, to remove concentrated (cycled up) water from the system. EVAPCO recommends an automated conductivity controller to maximize the water efficiency of your system. Based on recommendations from the water treatment company, the conductivity controller should open and close a motorized ball or solenoid valve to maintain the conductivity of the recirculating water. If a manual valve is used to control the rate of bleed it should be set to maintain the conductivity of the recirculating water during periods of peak load at the maximum level recommended by the water treatment company.

$$\text{Bleedrate (GPM[l/s])} = \frac{\text{Evaporation Rate (GPM[l/s])}}{(\text{Cycles of Concentration} - 1)}$$

\*Cycles of Concentration is the ratio of the concentration of dissolved ions in the recirculating water, divided by the concentration of dissolved ions in the makeup water.

### Galvanized Steel – Passivation

'White Rust' is a form of premature corrosion of the protective zinc layer on hot dip or mill galvanized steel which can occur as a result of improper water treatment control during the start-up of new galvanized equipment. The initial commissioning and passivation period is a critical time for maximizing the service life of galvanized equipment. EVAPCO recommends that the site specific water treatment protocol includes a passivation procedure which details water chemistry, any necessary chemical addition, and visual inspections during the first six (6) to twelve (12) weeks of operation. During this passivation period, recirculating water pH should be maintained above 7.0 and below 8.0 at all times. Since elevated temperatures have a harmful effect on the passivation process, the new galvanized equipment should be run without load for as much of the passivation period as is practical.

The following water chemistry promotes the formation of white rust and should be avoided during the passivation period:

1. pH values in the recirculating water greater than 8.3.
2. Calcium hardness (as CaCO<sub>3</sub>) less than 50 ppm in the recirculating water.
3. Anions of chlorides or sulfates greater than 250 ppm in the recirculating water.
4. Alkalinity greater than 300 ppm in the recirculating water regardless of pH value.

Changes in water chemistry control may be considered after the passivation process is complete as evidenced by the galvanized surfaces taking on a dull gray color. Any changes to the treatment program or control limits should be made slowly, in stages while documenting the impact of the changes on the passivated zinc surfaces.

- Operating galvanized evaporative cooling equipment with a water pH below 6.0 for any period may cause removal of the protective zinc coating.
- Operating galvanized evaporative cooling equipment with a water pH above 9.0 for any period may destabilize the passivated surface and create white rust.
- Repassivation may be required at any time in the service life of the equipment if an upset condition occurs which destabilizes the passivated zinc surface.

For more information on passivation and white rust, please download a copy of EVAPCO's Engineering Bulletin 36A at [evapco.com](http://evapco.com).

### Water Chemistry Parameters

The water treatment program designed for evaporative cooling equipment must be compatible with the unit’s materials of construction. Control of corrosion and scale will be very difficult if the recirculating water chemistry is not consistently maintained within the ranges noted in Table 4. In mixed metallurgy systems, the water treatment program should be designed to ensure protection of all the components used in the cooling water loop.

If a chemical water treatment program is used, all chemicals selected must be compatible with the unit’s materials of construction as well

Property	G-235 (Z-725) Galvanized Steel	Type 304 Stainless Steel	Type 316 Stainless Steel
pH	7.0 – 8.8	6.0 – 9.5	6.0 – 9.5
pH During Passivation	7.0 – 8.0	N/A	N/A
Total Suspended Solids (ppm)*	< 25	< 25	< 25
Conductivity (Micro-mhos/cm) **	< 2,400	< 4,000	< 5,000
Alkalinity as CaCO <sub>3</sub> (ppm)	75 - 400	< 600	< 600
Calcium Hardness CaCO <sub>3</sub> (ppm)	50 - 500	< 600	< 600
Chlorides as Cl (ppm) ***	< 300	< 500	< 2,000
Silica (ppm)	< 150	< 150	< 150
Total Bacteria (cfu/ml)	< 10,000	< 10,000	< 10,000

\* Based on standard EVAPAK® fill

\*\* Based on clean metal surfaces. Accumulations of dirt, deposits, or sludge will increase corrosion potential

\*\*\* Based on maximum coil fluid temperatures below 120°F (49°C)

**Table 4** – Recommended Water Chemistry Guidelines

as other equipment and piping used in the system. Chemicals should be fed through automatic feed equipment to a point which ensures proper control and mixing prior to reaching the evaporative cooling equipment. Chemicals should never be batch fed directly into the basin of the evaporative cooling equipment.

EVAPCO does not recommend the routine use of acid due to the destructive consequences of improper feeding; however, if acid is used as part of the site specific treatment protocol, it should be prediluted prior to introduction into the cooling water and fed by automated equipment to an area of the system which ensures adequate mixing. The location of the pH probe and acid feed line should be designed in conjunction with the automated feedback control to ensure that proper pH levels are consistently maintained throughout the cooling system. The automated system should be capable of storing and reporting operational data including pH reading and chemical feed pump activity. Automated pH control systems require frequent calibration to ensure proper operation and to protect the unit from increased corrosion potential.

The use of acids for cleaning should also be avoided. If acid cleaning is required, extreme caution must be exercised and only inhibited acids recommended for use with the unit’s materials of construction should be used. Any cleaning protocol, which includes the use of an acid, shall include a written procedure for neutralizing and flushing the evaporative cooling system at the completion of the cleaning. Flume/equalizer DO NOT ensure proper controlled mixing of water in multiple cells. Operate multiple cells individually.

## Control of Biological Contamination

Building water systems receive potable and non-potable water from either a public or private entity for their water supply. This water supply for the building water system can contain various waterborne pathogens, including Legionella bacteria, which can cause or contribute to various illnesses if aspirated, ingested or inhaled. Since evaporative cooling equipment uses the same building water, there is some potential that these pathogens, including Legionella, might propagate in the equipment. As such, evaporative cooling equipment should be located at such a distance and wind direction to minimize the possibility of tower discharge air and associated drift being drawn into building fresh air intakes or near areas frequented by at-risk individuals. Purchasers should obtain the services of a licensed professional engineer or a registered architect to certify that the location of evaporative cooling equipment is in compliance with applicable building, fire and clean air codes. (See EVAPCO’s Equipment Layout Manual for more information.)

In addition, it is recommended that the building employ a site-specific water management program that is designed to minimize the risk of Legionellosis associated with building water systems. (see ANSI/ASHRAE Standard 188 for further details.) And effective water management program also can help promote heat transfer efficiency and limit corrosion potential. Various water treatment professionals are available to provide assistance with such measures.

During operation, off-line cleaning of evaporative cooling equipment should be undertaken on a regular basis. Inspections should be undertaken on a regular basis and should include both monitoring of microbial populations via culturing techniques and visual inspections for evidence of biofouling. Additionally, drift eliminators should be inspected and maintained in good operation condition. Service personnel must wear proper protective equipment (including approved respiratory protection equipment) while undertaking such cleaning efforts or any other maintenance efforts on evaporative cooling equipment. Requirements for such protection equipment include, but are not limited to, OSHA standards set forth in 29 CFR 1910.132 et seq..

## **Gray Water and Reclaimed Water**

The use of water reclaimed from another process as a source of makeup water for evaporative cooling equipment can be considered as long as the resultant recirculating water chemistry conforms to the parameters noted in Table 4. It should be noted that using water reclaimed from other processes may increase the potential of corrosion, microbiological fouling, or scale formation. Gray water or reclaimed water should be avoided unless all of the associated risks are understood and documented as part of the site specific treatment plan.

## **Air Contamination**

Evaporative cooling equipment draws in air as part of normal operation and can scrub particulates out of the air. Do not locate the unit next to smokestacks, discharge ducts, vents, flue gas exhausts, etc. because the unit will draw in these fumes which may lead to accelerated corrosion or deposition potential within the unit. Additionally, it is important to locate the unit away from the building's fresh air intakes to prevent any drift, biological activity, or other unit discharge from entering the building's air system.

## Cold Weather Operation

EVAPCO counterflow evaporative cooling equipment is well suited to operate in cold weather conditions. The counterflow design encases the heat transfer media (fill and/or coils) completely, and protects it from the outside elements such as wind which can cause freezing in the unit.

When the evaporative cooling unit is going to be used during cold weather conditions, several items need to be considered including unit layout, recirculating water, unit recirculating piping, unit heat transfer coils, unit accessories and capacity control of the units.

### Unit Layout

Adequate unobstructed air flow must be provided for both the intake and discharge from the unit. It is imperative that the equipment minimize the risk of recirculation. Recirculation can result in condensation freezing the inlet louvers, fans and fan screens. The buildup of ice on these areas can adversely affect air flow and in more severe cases, lead to failure of these components. Prevailing winds can create icing conditions on the inlet louvers and fan screens adversely affecting airflow to the unit.

For additional information on unit layout, please refer to EVAPCO's Equipment Layout Manual.

### Freeze Protection of Recirculating Water

The simplest and most effective way of keeping the recirculated water from freezing is to use a remote sump. With a remote sump, the recirculating water pump is mounted remotely at the sump and whenever the pump is shut off, all recirculating water drains back to the sump. Recommendations for sizing the remote sump tank and recirculating water pumps for coil products are presented for Evaporative Condensers and Closed Circuit Coolers in their respective catalog bulletin. The pressure drop through the water distribution system measured at the water inlet is as follows in Table 5.

If a remote sump cannot be used, basin heaters are available to keep the recirculating water from freezing when the pump is turned off. Electric heaters, hot water coils, steam coils or steam injectors may be used to heat the basin water when the unit is shut down. However, the basin heater will not prevent the external water lines, pump or pump piping from freezing. The make-up water supply, overflow and drain lines, as well as the pump and pump piping up to the overflow level must be heat traced and insulated to protect them from damage. Any other connections or accessories at or below the water level, such as electronic water level controllers, must also be heat traced and insulated.

A condenser or cooler cannot be operated dry (fans on, pump off) unless the water is completely drained from the pan. The pan heaters are sized to prevent pan water from freezing only when the unit is completely shut down.

**NOTE:** *Using basin heaters will not prevent the fluid in the coils, nor the residual water in the pump or pump piping from freezing.*



Evaporative Condenser Model Number		Closed Circuit Cooler Footprint	Required Inlet Pressure (psi)	Required Inlet Pressure (kPa)
<b>ATC-E Products</b>	<b>eco-ATC-A Products</b>	<b>ATWB, eco-ATW &amp; eco-ATWE Products</b>		
50E to 165E	122A to 263A	3' and 4' wide units**	2.0	13.8
170E to 247E	160A to 326A	8.5'x7.5'	2.0	13.8
218E to 305E	205A to 504A	8.5'x9'	2.0	13.8
246E to 473E	395A to 671A	8.5'x10.5', 8.5'x12', 8.5'x14'	2.0	13.8
486E to 630E	451A to 804A	8.5'x18'	3.0	20.7
508E to 755E	444A to 1013A	8.5'x21'	4.0	27.6
643E to 950E	441A to 988A	8.5'x24', 28'	2.5	17.2
639E to 926E	300-501A to 642-1002A	17'x12', 17'x14'	2.5	17.2
XE298E to XC462E, XE596E to XC925E	391-694A to 879-1388A	10'x12', 10'x24', 20'x12'	3.7	25.5
XE406E to XC669E, XE812E to XC1340E	325 to 632A, 408 to 685A, 432 to 923A	10'x18', 10'x36', 20'x18'	5.7	39.3
428E to 892E	650 to 1263A, 770 to 1369A, 1020 to 1847A	12'x12', 12'x14', 12'x18'	3.5	24.1
858E to 1784E	710 to 1264A, 816 to 1370A, 1021 to 1848A	12'x24', 12'x28', 12'x36'	2.5	17.2
857E to 1783E	1293 to 2515A, 1493 to 2654A, 2182 to 3583A	24'x12', 24'x14', 24'x18'	3.0	20.7
1879E to 3459E	585 to 1001A, 1120 to 1993A	24'x24', 24'x28', 24'x36'	2.5	17.2
791E to 967E, 1625E to 1925E	1159 to 1983A, 2247 to 3846A	12'x20', 12'x40'	3.5	24.1
1616E to 1915E, 2855E to 3714E		24'x20', 24'x40'	3.5	24.1
<b>CATC Products</b>		<b>CATW Products</b>		
181 thru 373		7.5'x8', 7.5'x12', 7.5'x14'	2.0	13.8
362 thru 504		7.5'x18'	3.0	20.7
<b>LRC Products</b>		<b>LRWB Products</b>		
25 to 72		3' wide units	1.0	6.9
76 to 114		5'x6'	2.0	13.8
108 to 183		5'x9'	2.0	13.8
190 to 246		5'x12'	2.0	13.8
188 to 379		8' wide units	2.0	13.8
<b>LSC-E Products</b>		<b>LSWE Products</b>		
36 to 80		4'x6'	1.5	10.3
90 to 120		4'x9'	1.5	10.3
135 to 170		4'x12', 4'x18'	1.5	10.3
185 to 385		5.5'x12', 5.5'x18'	2.0	13.8
400 to 1610		10'x12', 10'x18', 10'x24', 10'x36'	2.5	17.2
		8'x12', 8'x18', 8'x24', 8'x36'	3.0	20.7
		<b>ESW4 Products</b>		
		8.5'x6'	3.0	20.7
		8.5'x9'	2.5	17.2
		8.5'x12'	2.5	17.2
		8.5'x18'	3.0	20.7
		12'x12'	2.0	13.8
		12'x18'	3.0	20.7
		14'x22'	2.0	13.7
<b>PMC-E Products</b>	<b>eco-PMC Products</b>			
175E to 375E	183 to 387	-	2.0	13.7
332E to 1586E	275 to 1662		4.0	27.6
420E to 2019E	314 to 2191		3.5	24.1
<b>PHC Products</b>				
S208 to S411 (12'x12'), L403 to L842 (12'x24')			3.0	20.7
S416 to S822 (12'x24')			3.0	20.7
5373 to 5541 (12'x18'), 5746 to 51182 (12'x36')		-	4.0	27.6
D621 to D858 (12'x24'), D1241 to D1716 (24'x24')			5.0	34.5
D790 to D1025 (14'x26')			4.5	31
D1580 to D 2050 (28'x28')			4.5	31

Note: For multi-cell units, the inlet pressure shown is per cell.

\*\* Not available as eco-ATWE

**Table 5** - Required Recirculating Water Inlet Pressure for Remote Sump Application - Coil Products Only

## Freeze Protection of Closed Circuit Cooler Coils

The simplest and most effective way of protecting the heat exchanger coil from freezing is to use an inhibited ethylene or propylene glycol anti-freeze. If this is not possible, an auxiliary heat load and minimum flow rate must be maintained on the coil at all times so that the water temperature does not drop below 50°F (10°C) when the cooler is shut down. See Table 6 for recommended minimum flow rates.

If an anti-freeze solution is not used, the coil must be drained immediately whenever the pumps are shut down or flow stops. This is accomplished by having automatic drain valves and air vents in the piping to and from the cooler. Care must be taken to ensure that the piping is adequately insulated and sized to allow the water to flow quickly from the coil. This method of protection should be used only in emergency situations and is neither a practical nor recommended method of freeze protection. Coils should not be drained for an extended period of time, as internal corrosion may occur.

When the unit is in operation during freezing weather, some type of capacity control is normally required in order to keep water temperatures from dropping below 50°F (10°C). Operating dry with a remote sump is an excellent way of reducing unit capacity at low temperatures. Other methods of capacity control include two-speed motors, VFDs and fan cycling. These can be used individually or in combination with dry/remote sump operation.

Closed Circuit Cooler Footprint	Minimum Flows			
	Standard Flow GPM	Series Flow GPM	Standard Flow l/s	Series Flow l/s
<b>ATWB Products, eco-ATW &amp; eco-ATWE</b>				
3'x3' <sup>**</sup>	—	26	—	1.6
4' wide units <sup>**</sup>	74	37	4.7	2.3
7' wide units	140	70	8.8	4.4
8.5'x7.5'	148	74	9.3	4.7
8.5'x9' to 8.5'x21'	160	80	10	5
17'x12', 17'x14'	320	160	20	10
10'x12', 10'x18'	188	94	11.9	5.9
10'x24, 10'x36', 20'x12', 20'x18'	376	188	23.7	11.9
20'x24', 20'x36'	752	376	47.4	23.7
12'x12', 12'x14', 12'x18', 12'x20'	232	116	14.6	7.3
12'x24', 12'x28', 12'x36', 12'x40'	464	232	29.3	14.6
24'x12', 24'x14', 24'x18', 24'x20'	464	232	11	11
24'x24', 24'x28', 24'x36', 24'x40'	928	464	58.5	29.3
<b>LRWB Products</b>				
3' wide units	60	30	3.8	1.9
5' wide units	94	47	5.9	3
8' wide units	148	74	9.3	4.7
<b>LSWE Products</b>				
4'x6', 4'x9', 4'x12', 4'x18'	66	30	66	30
5.5'x12', 5.5'x18'	94	47	94	47
8'x12', 8'x18'	148	74	148	74
8'x24', 8'x36'	296	148	296	148
10'x12', 10'x18'	188	94	188	94
10'x24, 10'x36'	376	188	376	188
<b>ESW4 Products</b>				
8.5'x6'-LP	100	50	6.3	3.2
8.5'x9', 8.5'x12', 12'x12'-LP, 12'x12'-SP	160	80	10.1	5
8.5'x18', 12'x12'-LF, 12'x12'-SF, 12'x18'-LF, 12'x18'-X-SF	240	120	15.1	7.6
12'x18'-X-LP, 12'x18'-X-SP	320	160	20.2	10.1
12'x18'-X-LF, 12'x18'-X-SF	480	240	30.3	15.1
14'x22'	440	220	27.8	13.9

\*\* Not available as eco-ATWE

**Table 6** - Closed Circuit Cooler Minimum Recommended Flow Rate

## Unit Accessories

The appropriate accessories to prevent or minimize ice formation during cold weather operation are relatively simple and inexpensive. These accessories include cold water basin heaters, the use of a remote sump, electric water level control and vibration cut out switches. Each of these optional accessories ensures that the cooler or condenser will function properly during cold weather operation.

### Cold Water Basin Heaters

Optional basin heaters can be furnished with the unit to prevent the water from freezing in the basin when the unit is idle during low ambient conditions. The basin heaters are designed to maintain 40°F (4°C) basin water temperature at a 0°F (-18°C) ambient temperature. The heaters are only energized when the recirculating pumps are off and no water is flowing over the heat exchanger coil. As long as there is a heat load and water is flowing over the heat exchanger coil, the heaters do not need to operate. Other types of basin heaters to consider would include: hot water coils, steam coils or steam injectors.

### Remote Sumps

A remote sump located in an indoor heated space is an excellent way to prevent freezing in the cold water basin during idle or no load conditions because the basin and associated piping will drain by gravity whenever the recirculating pump is idle. EVAPCO units built for remote sump operation do not include recirculating water pumps.

### Electric Water Level Control

Optional electric water level control packages can be furnished to replace the standard mechanical float and valve assembly. The makeup water pressure for electronic water level control should be maintained between 5 and 100 psig (35 and 690 kPa). The electric water level control eliminates the freezing problems experienced by the mechanical float. In addition, it provides accurate control of the basin water level and does not require field adjustment even under varying load conditions. Please note: the standpipe assembly, make up piping and solenoid valve must be heat traced and insulated to prevent them from freezing.

### Vibration Cut Out Switches

During severe cold weather conditions, ice can form on the fans of cooling towers causing excessive vibration. The optional vibration switch shuts the fan off avoiding potential damage to or failure of the drive system.

## Capacity Control Methods for Cold Weather Operation

Induced draft and forced draft coolers or condensers require separate guidelines for capacity control during cold weather operation.

The sequence of control for a unit operating at low ambient conditions is much the same as a cooler or condenser operating under summer conditions provided that the ambient temperature is above freezing. When the ambient temperatures are below freezing, additional precautions must be taken to avoid the potential for damaging ice formation.

The most effective way to avoid ice formation in and on a closed circuit cooler or condenser during the winter is to run the unit DRY. In dry operation, the recirculation pump is turned off, the basin drained, and air passes over the coil. Instead of using evaporative cooling to cool the process fluid or condense the refrigerant, sensible heat transfer is utilized, so there is no recirculation water to freeze. If this method will be used on a forced draft unit, be sure to verify that the motor and drives have been properly sized to handle the reduction in static pressure experienced when the spray water is turned off.

It is very important to maintain close control of the cooler or condenser during winter operation. EVAPCO recommends that an absolute MINIMUM leaving water temperature of 42° F (6°C) must be maintained for cooler applications. The higher the leaving temperature from the cooler or condenser, the lower the potential for ice formation.

### Induced Draft Unit Capacity Control

The simplest method of capacity control is cycling the fan motor on and off in response to the leaving fluid temperature of the cooler or condenser. However, this method of control results in larger temperature differentials and longer periods of down time. During extremely low ambient conditions, the moist air may condense and freeze on the fan drive system. Therefore, fans must be cycled during extremely low ambient conditions to avoid long periods of idle time when water is flowing over the coil. The number of start/stop cycles must be limited to no more than six per hour.

A better method of control is the use of two-speed fan motors. This allows an additional step of capacity control. This additional step reduces the water temperature differential, and therefore, the amount of time the fans are off. In addition, two-speed motors provide savings in energy costs, since the cooler or condenser has the potential to operate on low speed for the reduced load requirements.

The best method of capacity control during cold weather operation is the use of a variable frequency drive (VFD). This allows the closest control of the leaving water temperature by allowing the fan(s) to run at the appropriate speed to closely match the building load. As the building load decreases, the VFD control system may operate for long periods of time at fan speeds below 50%. Operating a low leaving water temperature and low air velocity through the unit can cause ice to form. It is recommended that the minimum speed of the VFD be set at 50% of full speed to minimize the potential for ice to form in the unit.

## Forced Draft Unit Capacity Control

The most common methods of capacity control are cycling the single speed fan motors, using two-speed motors or pony motors and utilizing variable frequency drives to control the cooler or condenser fans. Although capacity control methods for forced draft units are similar to those used for induced draft units, there are slight variations.

The simplest method of capacity control for forced draft units is to cycle the fan(s) on and off. However, this method of control results in larger temperature differentials and periods of time with the fans off. When the fans are cycled off, the water falling through the unit can draw air flow into the fan section. During extremely low ambient conditions, this moist air may condense and freeze on the cold components of the drive system. When conditions change and cooling is needed, any amount of ice that has formed on the drive system can severely damage the fans and fan shafts. **Therefore, fans MUST be cycled during low ambient operation to avoid long periods of idle fan operation. Excessive cycling can damage the fan motors. Limit the number of cycles to a maximum of six per hour.**

Two speed or pony motors offer a better method of control. This additional step of capacity control will reduce water temperature differentials and the amount of time that the fans are off. This method of capacity control has proven effective for applications where load variations are excessive and cold weather conditions are moderate.

The use of a variable frequency drive provides the most flexible method of capacity control for forced draft units. The VFD control system allows the fans to run at nearly an infinite range of speeds to match the unit capacity to the system load. During periods of reduced load and low ambient temperatures, the fans must maintain enough speed to ensure positive air flow through the unit. This positive air flow in the unit will prevent moist air from migrating towards the cold fan drive components reducing the potential for condensation to form and freeze on them. The VFD control system should be implemented for applications that experience fluctuating loads and severe cold weather conditions.

## Ice Management

When operating an evaporative cooling unit in extreme ambient conditions, the formation of ice is inevitable. The key to successful operation is to control or manage the amount of ice that builds up in the unit. If extreme icing occurs, it can lead to severe operational difficulties as well as potential damage to the unit. Following these guidelines will minimize the amount of ice that forms in the unit leading to better operation during the cold weather season.

### Induced Draft Units

When operating an induced draft unit during the cold weather season, the control sequence must have a method to manage the formation of ice in the unit. The simplest method of managing the amount of ice buildup is by cycling the fan motors off while keeping the pump on. During these periods of idle fan operation, the warm water that is absorbing the building load flows thru the coil to help melt the ice that has formed in the coil, basin or louver areas.

**NOTE:** *Using this method during periods of high winds can cause blow through, resulting in splash-out and ice formation. To help prevent blow through and splash-out, maintain a minimum 50% fan speed.*

In more severe climates, the incorporation of a defrost cycle can be used to mitigate and/or eliminate any detrimental effects of ice in the unit. During the defrost cycle, the fans are reversed at **half speed** while the recirculating pump flows water through the unit's water distribution system. Operating the unit in reverse will melt any ice or frost that may have formed in the unit or on the air intake louvers. **The defrost cycle requires the use of two speed motors with reverse cycle starters or reversible variable frequency drives.** All motors supplied by EVAPCO are capable of reverse operation.

The defrost cycle should be incorporated into the normal control scheme of the cooler or condenser system. The control system should allow for either a manual or automatic method of controlling frequency and length of time required to completely defrost the ice from the unit. The frequency and length of the defrost cycle is dependent on the control methods and ambient cold weather conditions. Some applications will build ice quicker than others which may require longer and more frequent defrost periods. **Frequent inspection of the unit will help "fine-tune" the length and frequency of the defrost cycle.**

### Forced Draft Units

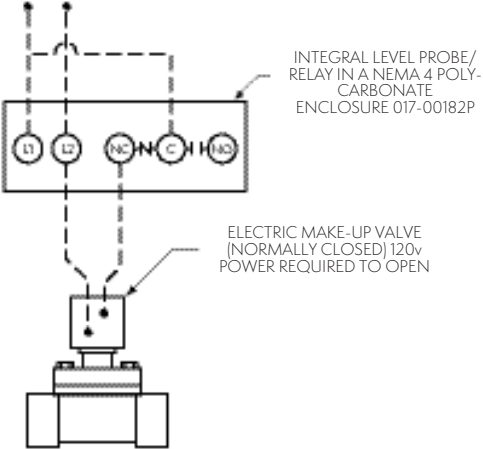
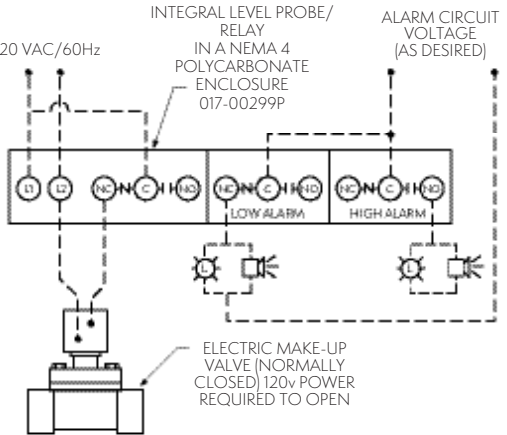
Defrost cycles are **NOT** recommended for forced draft units, since allowing the leaving water temperature set point to rise causes the fans to be off for very long periods of time. This is not recommended for forced draft coolers or condensers because of the potential for freezing the fan drive components. Therefore, the defrost cycle is an inappropriate method of ice management for forced draft units. However, low speed fan operation or variable frequency drives maintain a positive pressure in the unit which helps prevent ice formation on the fan drive components.

For more information on cold weather operation, please download a copy of EVAPCO's Engineering Bulletin 23 at [evapco.com](http://evapco.com)

# Troubleshooting

Problem	Possible Cause	Remedy
<b>Overramping Fan Motors</b>	Reduction in air static pressure	<ol style="list-style-type: none"> <li>1. On a forced draft unit verify that the pump is on, and water is flowing over the coil. If the pump is off, and the unit was not sized for dry operation, the motor may over-amp.</li> <li>2. If the forced draft unit is ducted, verify that the design ESP matches the actual ESP.</li> <li>3. Verify the correct pump rotation direction. If the pump is rotating incorrectly, it will result in less water flow, and therefore less overall static pressure.</li> <li>4. Check the basin water level against the recommended level.</li> </ol> <p><i>NOTE: Air density directly affects AMP reading. Low air density can cause the fans to spin faster, thus increasing the amp draw.</i></p>
	Electrical issue	<ol style="list-style-type: none"> <li>1. Check voltage across all three legs of the motor.</li> <li>2. Verify that the motor is wired per the wiring diagram, and connections are tight.</li> </ol>
	Fan rotation	Verify that the fan is rotating in the correct direction. If not, switch the leads so it runs correctly.
	Mechanical failure	Verify that the fan and motor turn freely by hand. If not, there may be damage to the internal motor components or bearings.
	Belt tension	Check for proper belt tension. Extreme belt tension can cause the motor to overamp.
<b>Unusual Motor Noise</b>	Motor running single-phase	Stop motor and attempt to start it. Motor will not start again if single phased. Check wiring, controls and motor.
	Motor leads connected incorrectly	Check motor connections against wiring diagram on motor.
	Bad bearings	Check lubrication. Replace bad bearings.
	Electrical unbalance	Check voltage and current of all three lines. Correct if required.
	Air gap not uniform	Check and correct bracket fits or bearing.
	Rotor unbalance	Rebalance.
	Cooling fan hitting end bell guard	Reinstall or replace fan.
<b>Incomplete Spray Pattern</b>	Nozzles clogged	Remove nozzles and clean. Flush water distribution system.
	Pump running backwards	Visually verify pump rotor rotation by turning pump off and then on. Verify amp draw.
	Inadequate pump flow for remote sump	Confirm inlet pressure at header meets required values.
	Strainer clogged	Check fan, fan shaft for proper alignment. Adjust cylinder to provide blade tip clearance.
<b>Fan Noise</b>	Blade rubbing inside of fan cylinder (induced draft models)	Check fan, fan shaft for proper alignment. Adjust cylinder to provide blade tip clearance.

Problem	Possible Cause	Remedy
<b>Scaled Inlet Louvers on AT Units</b>	Improper water treatment, insufficient bleed rates or excessive cycling of the fan motors, or high concentrations of solids in water.	Scale should not be removed using a power washer or wire brush because it could damage the louvers. Remove the louver assemblies and let them soak in the cold water basin of the unit. The water treatment chemicals in the unit will neutralize and dissolve the buildup of scale.  <i>NOTE: The time required for soaking the inlet louvers depends on the severity of the scale buildup.</i>  <i>NOTE: This assumes chemicals are being used.</i>
<b>Overramping Pump Motors</b>	Initial start-up	If the unit has only run for a few hours, the pump may overramp until the pump wear ring has worn in. In this case, it would only be small percentages, not 15 or 20%. Normally, after a few hours, the pump amp readings will reduce and level off.
	Mechanical failure	Verify that the pump can turn freely by hand. If not, pump most likely needs to be replaced.
	Electrical issue	Verify that the pump has been wired properly. Verify that the voltage supplying the pump is correct.
	Misconception of head increase or decrease	<i>NOTE: Increase or decrease in pump flow as a result of clogged or blown out nozzles or headers should NOT cause the pump to over amp.</i>
<b>Makeup Valve Will Not Shut Off</b>	Make-up water pressure too high	Mechanical makeup valve water pressure must be between 20 and 50psi (138 and 345 kPa). If pressure is too high, the valve will not close. A pressure reducing valve can be added to lower the pressure. For the 3 and 5 Probe Electronic Water Level Control Package, the electrical actuator has a 5 to 125 psi (34 to 862 kPa) water pressure requirement.
	Debris in solenoid	Clean out solenoid of any debris.
	Frozen float ball	Inspect, and if so, float or valve may need to be replaced.
	Float ball is full of water	Check ball for leaks and replace.
<b>Water Constantly Blowing Out Overflow Connection</b>	This can happen on forced draft units due to the positive pressure in the casing section. Overflow connection has not been piped at all or properly	Pipe the overflow with a P-trap to an appropriate drain.
	Incorrect water level	Verify actual operating level versus O&M recommended levels
<b>Water Intermittently Blowing Out Overflow Connection</b>	This is normal	This is normal. The bleed line for the unit is piped to the overflow connection.
<b>Cold Water Basin Overflowing</b>	Problem with makeup line.	Refer to Makeup Valve or Electronic Water Level section.
	If multi-cell unit, there may be an elevation problem.	Make sure that multi-cell units are installed level to one another. If they are not, it can cause overflowing in one cell.
<b>Low Pan Water Level</b>	Electronic Water Level Control	See EWLC Section
	Float Ball not set correctly	Adjust float ball up or down to obtain proper water level.  <i>NOTE: The float ball is set to the operating level at the factory.</i>

Problem	Possible Cause	Remedy
<b>Rusting Stainless Steel</b>	Foreign material on surface of SS	Rust spots that show up on the surface of the unit are typically not signs of the base stainless steel material corroding. Often, they are foreign material, such as welding slag, that has collected on the surface of the unit. The rust spots will be located around where there has been welding. These areas may include the coil connections, the cold water basin near the support steel, and around field erected platforms and catwalks. The rust spots can be removed with a good cleaning. EVAPCO recommends using either Naval Jelly or a good stainless steel cleaner, such as Mother's Wax in conjunction with a Scotch-Brite pad. Maintenance of the unit's surface should be done on a regular basis.
<b>Cracking Fluid Cooler Insulation</b>	Cracking paint	Most of the time, it is the paint that is cracking and not the insulation. If the paint is degrading, it should be touched up to maintain the finish on the insulation. It is recommended that maintaining the finish of the insulation paint be a part of the standard maintenance program. If the insulation is cracking, see your local Evapco representative for further guidance.
<b>Electric Water Level Control Not Working</b> 	The valve won't open or close	<ol style="list-style-type: none"> <li>1. Verify that water pressure is above 5psi (34 kPa) and below 100psi (689 kPa).</li> <li>2. Verify wiring with wiring diagram. Check supply voltage.</li> <li>3. Verify that there is not a blockage in the Y-Strainer</li> <li>4. Confirm the probes are not dirty.</li> <li>5. Check Red LED on circuit board. If it is on, the valve should be closed.</li> </ol> <p><b>For a 3-Probe Assembly:</b></p> <p><b>Simulate "Low Water Condition" - LED OFF</b>            After cleaning the probes, lift probe assembly out of the stand pipe. This will simulate a "low water condition". Check the contacts for proper position.</p> <ul style="list-style-type: none"> <li>- The contact between "C" and "NC" should now be closed and water makeup valve should be energized (valve open)</li> </ul> <p><b>Simulate "High Water Condition" - LED ON</b></p> <ul style="list-style-type: none"> <li>- Connect a jumper wire between the longest probe and the shortest probe. The contact between "C" and "NC" should now be open and the water makeup valve should be de-energized (valve closed)</li> </ul>
<b>Electric Water Level Control Not Working</b> 		<p><b>For a 5-Probe Assembly:</b></p> <p><b>Simulate "Low Water Condition"</b>            After cleaning the probes, lift probe assembly out of the stand pipe. This will simulate a "low water condition". Check the contacts for proper position.</p> <ul style="list-style-type: none"> <li>- Differential Contacts: C to NC - closed - Water make-up valve energized - <b>LED = OFF</b></li> <li>- High Alarm Contacts: C to NO - open - High alarm circuit de-energized - <b>LED = OFF</b></li> <li>- Low Alarm Contacts: C to NC - closed - Low alarm circuit energized - <b>LED = OFF</b></li> </ul> <p><b>Simulate "High Water Condition"</b>            Connect a jumper wire between the longest probe (ground) and all other probes (high limit, high alarm, and low alarm). Check the contacts for proper position.</p> <ul style="list-style-type: none"> <li>- Differential Contacts: C to NC - open - Water make-up valve de-energized - <b>LED = ON</b></li> <li>- High Alarm Contacts: C to NO - closed - High alarm circuit energized - <b>LED = ON</b></li> <li>- Low Alarm Contacts: C to NC - open - Low alarm circuit de-energized - <b>LED = ON</b></li> </ul>

## Replacement Parts

EVAPCO has replacement parts available for immediate shipment. Most orders ship within 24 hours from time of order!

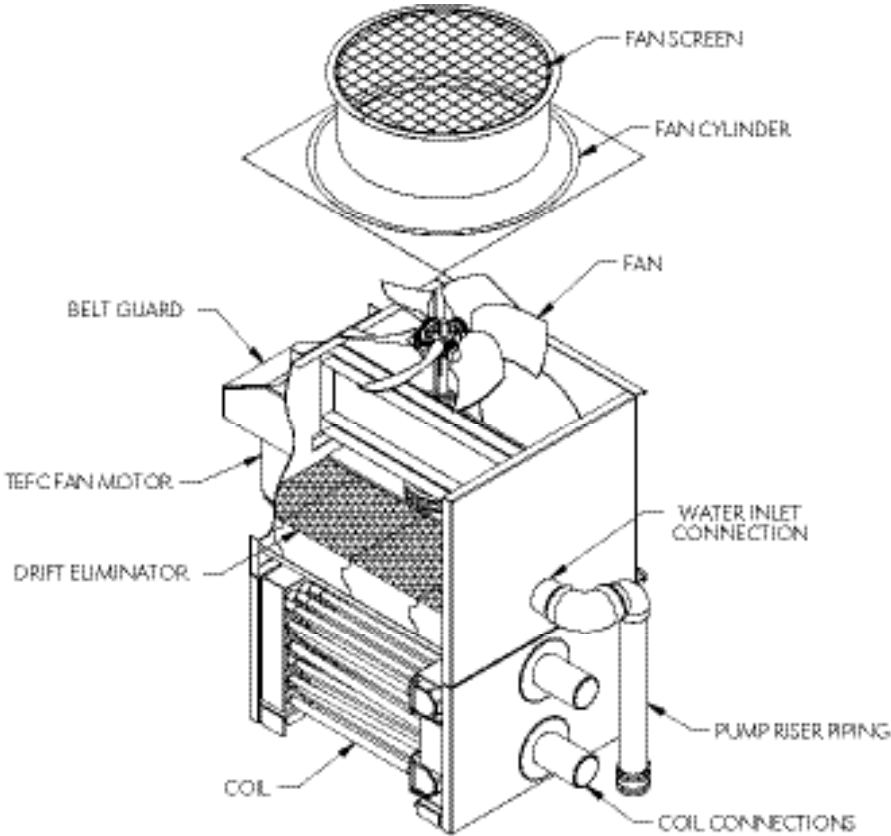
The following pages contain exploded view drawings of all current EVAPCO closed circuit coolers and condensers. Please use these drawings to help identify the major parts of your unit. To order replacement parts, please contact your local EVAPCO representative or Mr. GoodTower Service Center. The EVAPCO representative contact information is located on the unit's nameplate or can be found by visiting [www.evapco.com](http://www.evapco.com) ([www.evapco.eu](http://www.evapco.eu)).

Additionally, your local EVAPCO representative or Mr. GoodTower Service Center can provide FREE unit inspections to help ensure your equipment operates at peak performance regardless of the original manufacturer!

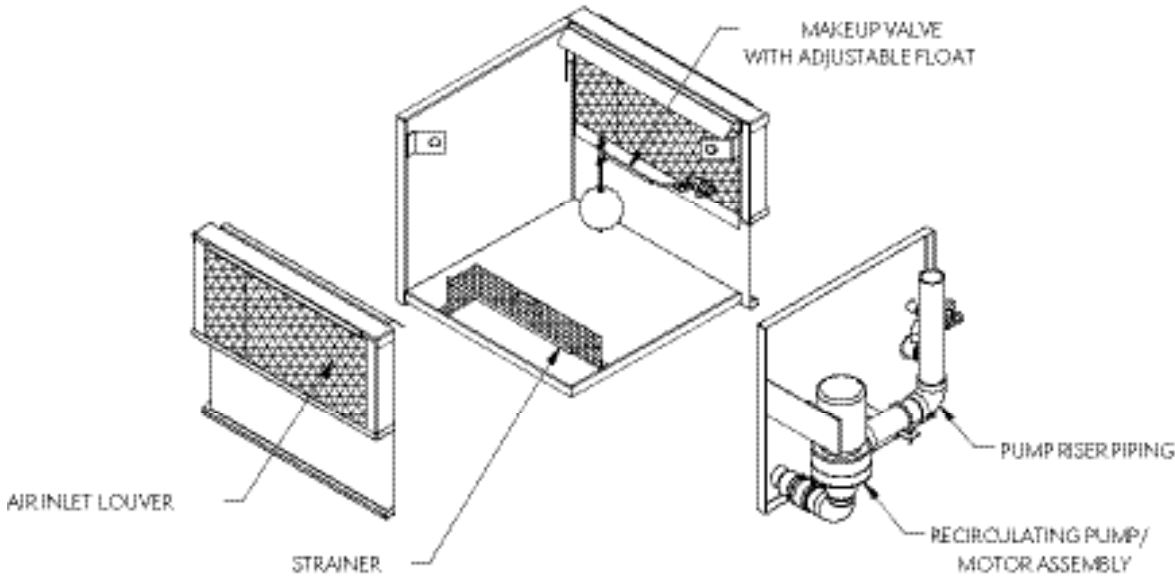


# ATWB & eco-ATWB 3' Wide Units

## FAN & COIL CASING SECTION

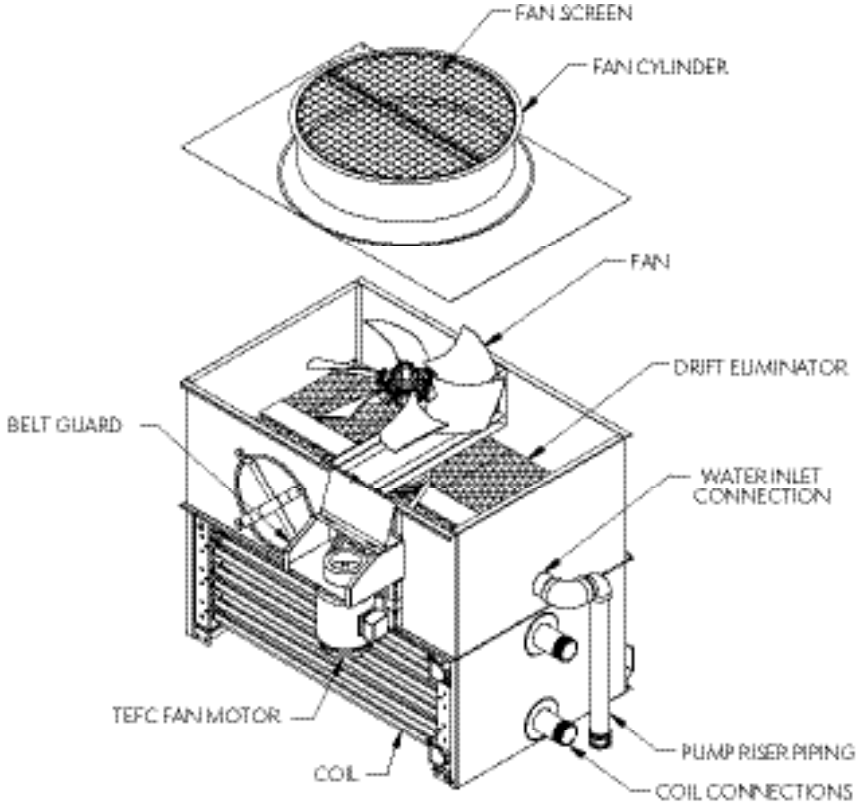


## PAN SECTION

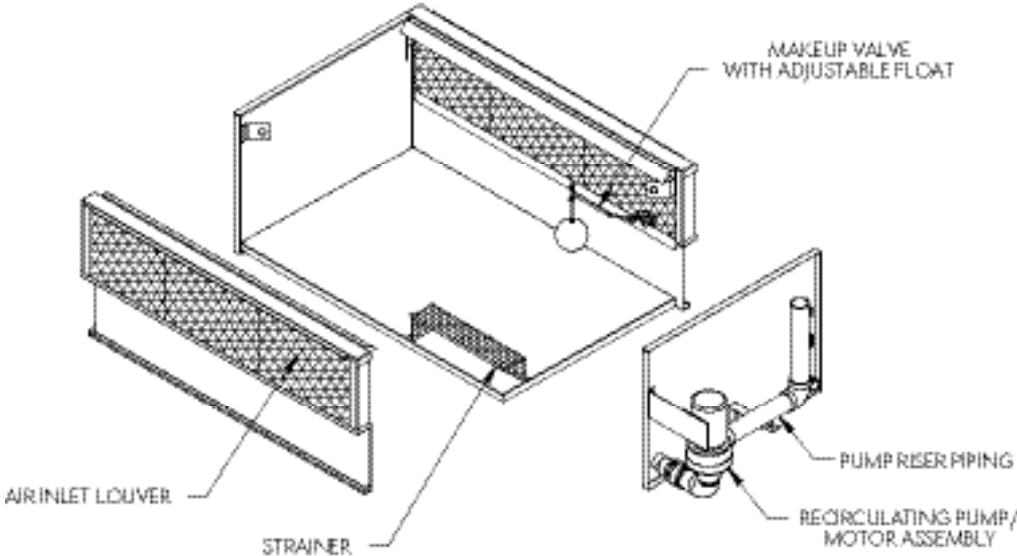


# ATC-E/ATWB/eco-ATWB 4'x4' & 4'x6' Wide Units

## FAN & COIL CASING SECTION

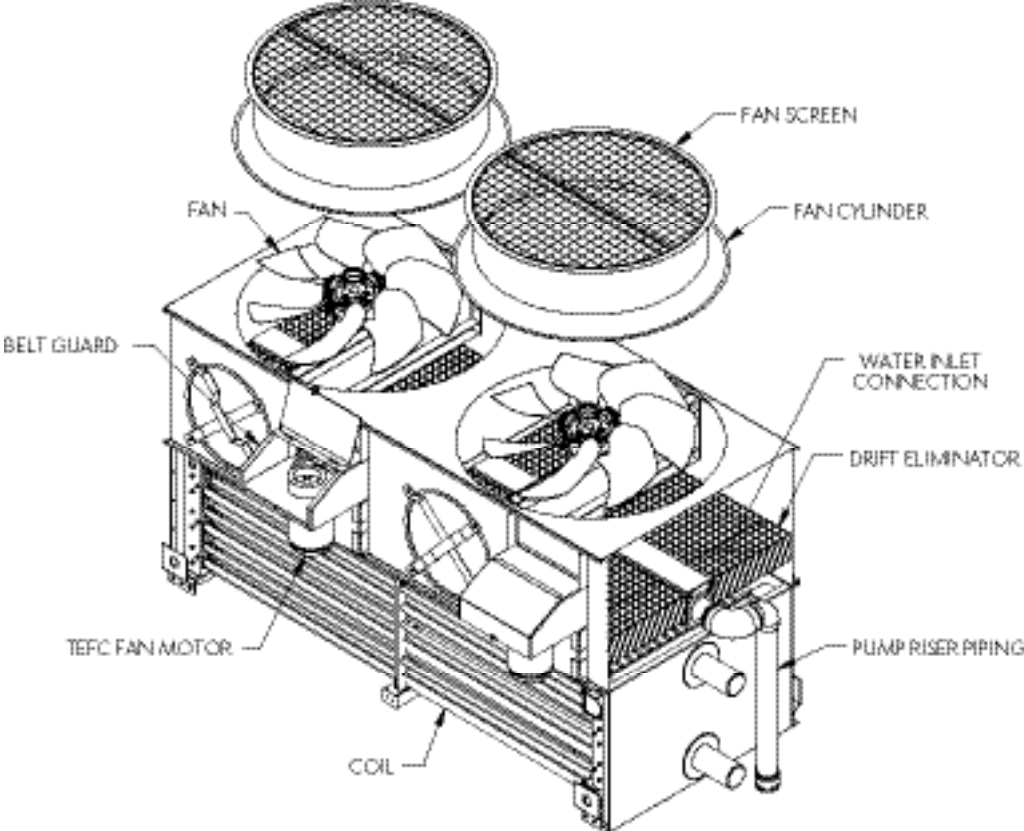


## PAN SECTION

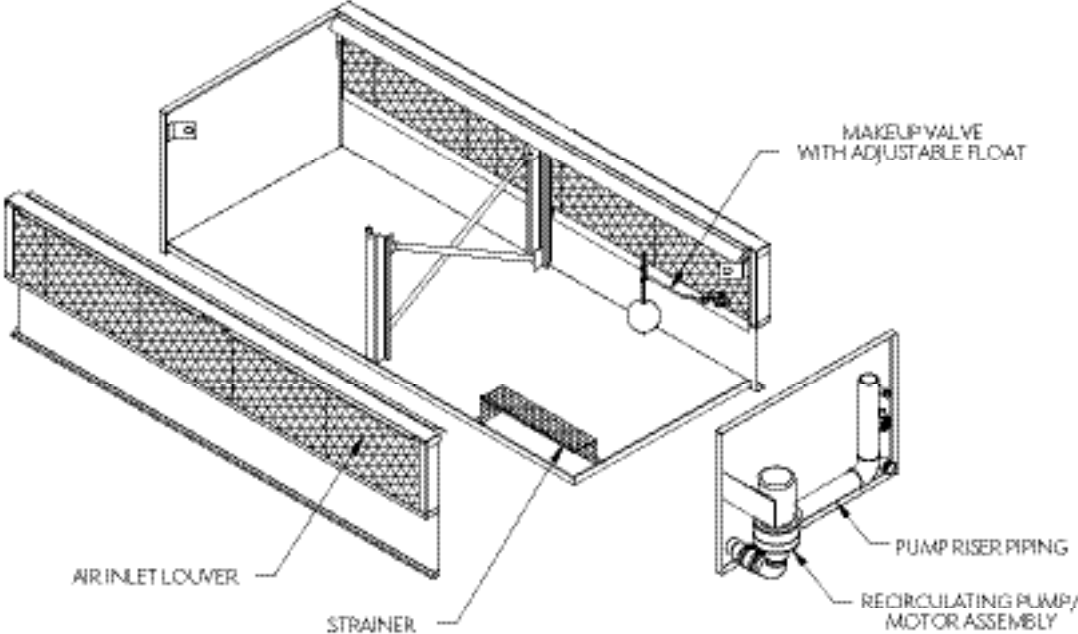


# ATC-E/ATWB/eco-ATWB 4'x9' & 4'x12' Wide Units

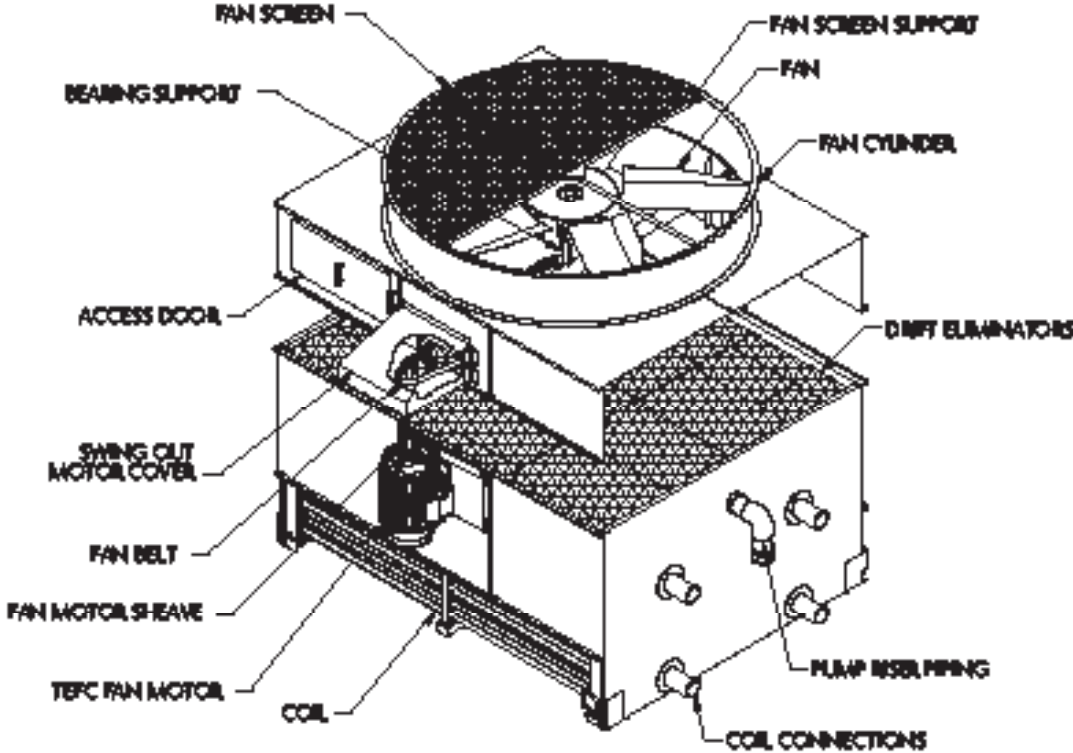
## FAN & COIL CASING SECTION



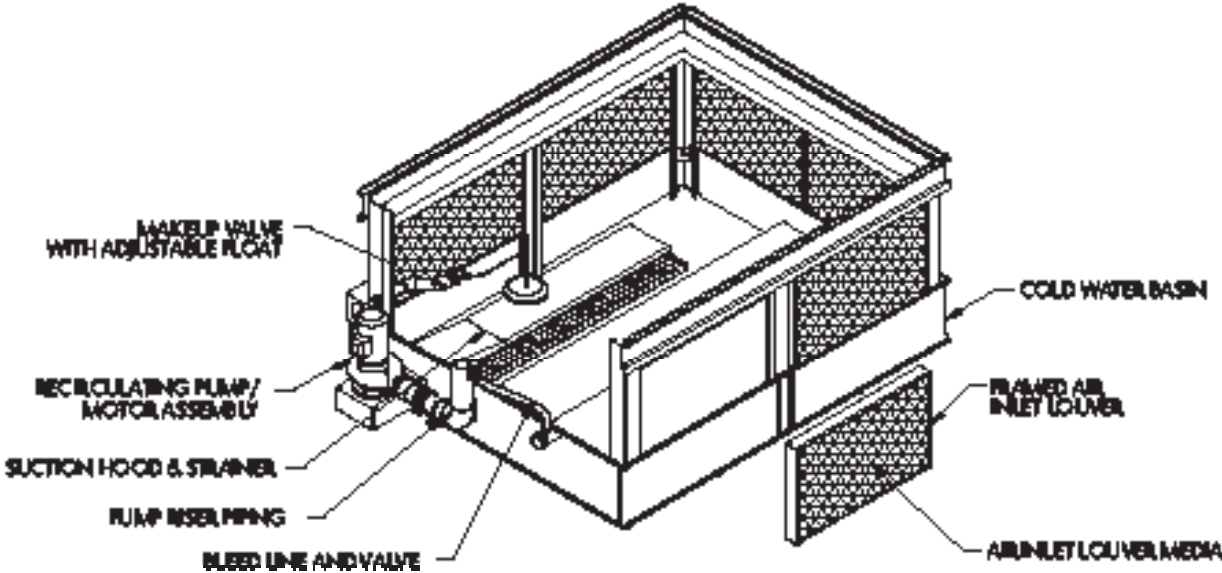
## PAN SECTION



FAN & COIL CASING SECTION

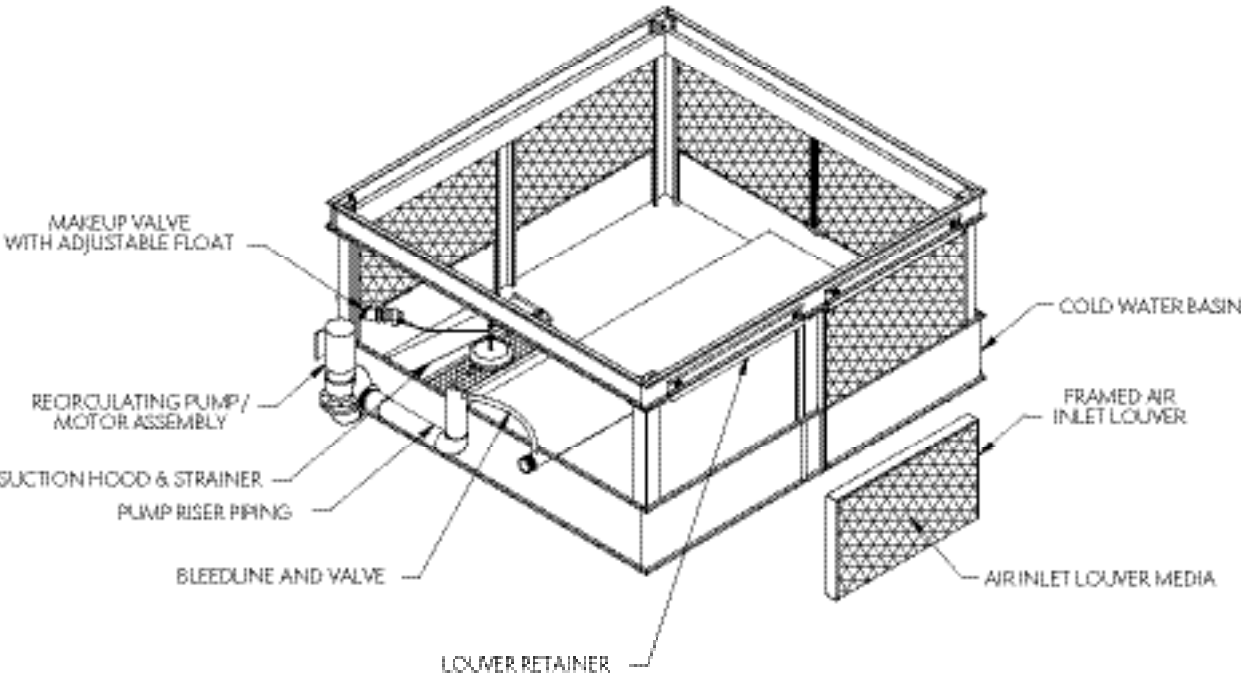
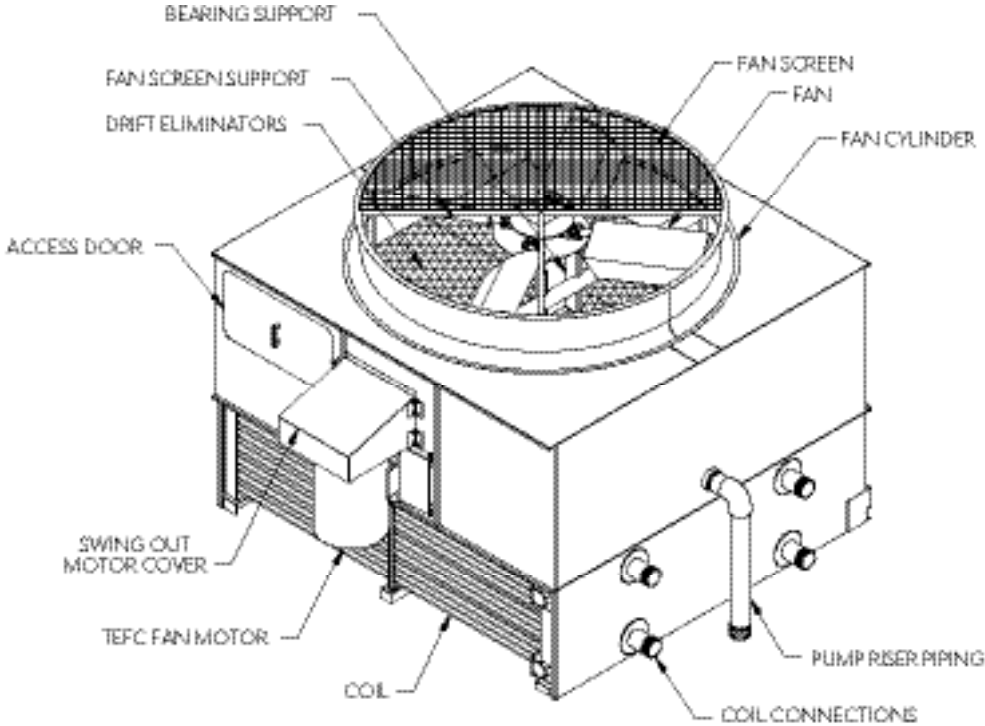


PAN SECTION



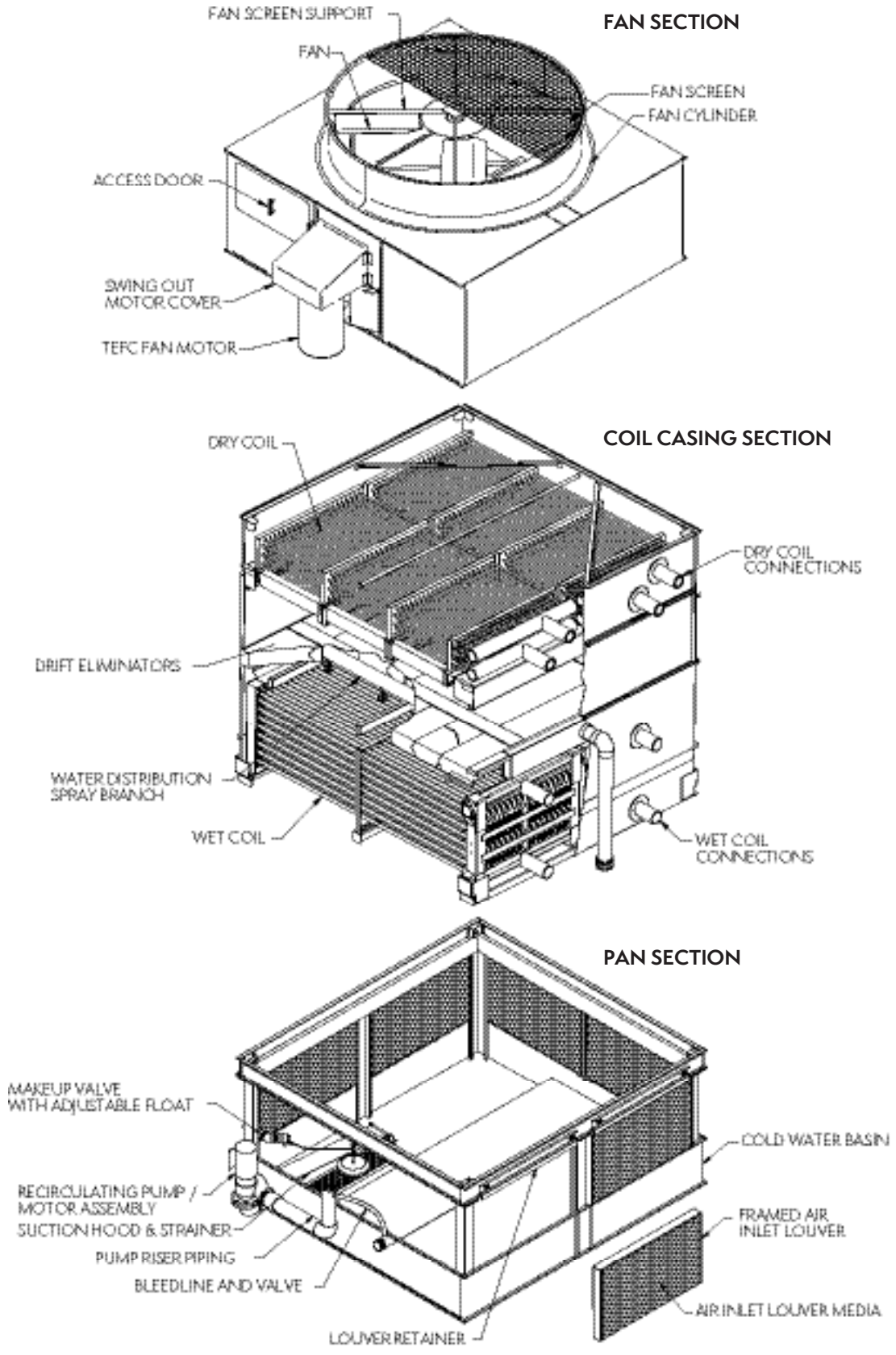
ATC-E/ATWB/eco-ATC-A/eco-ATWB 8' & 8.5' Wide Units

FAN & COIL CASING SECTION

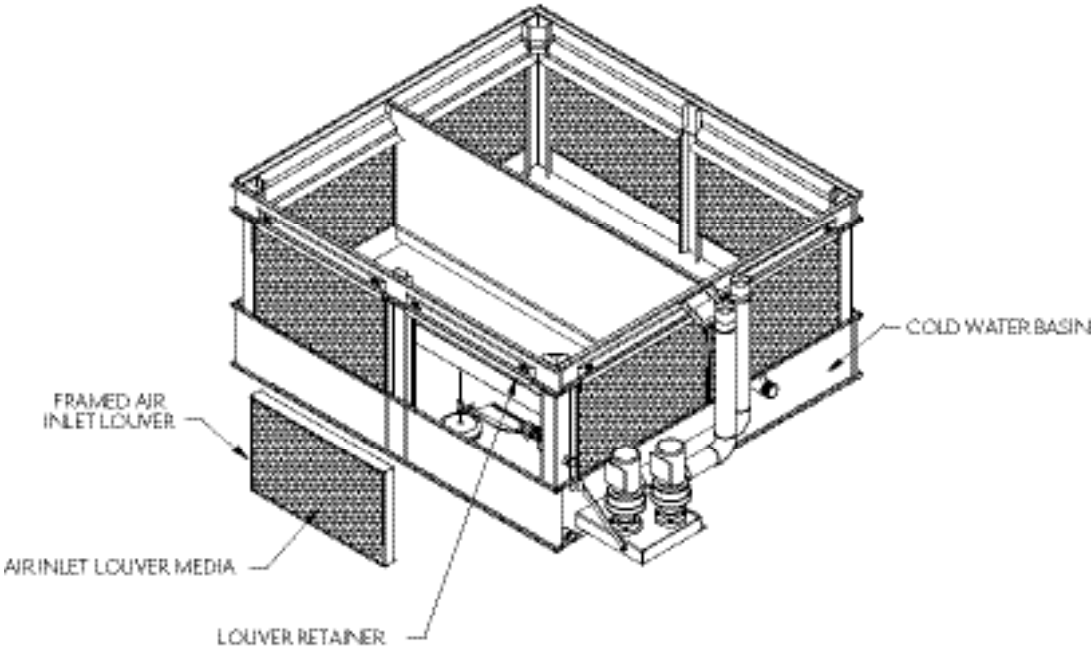
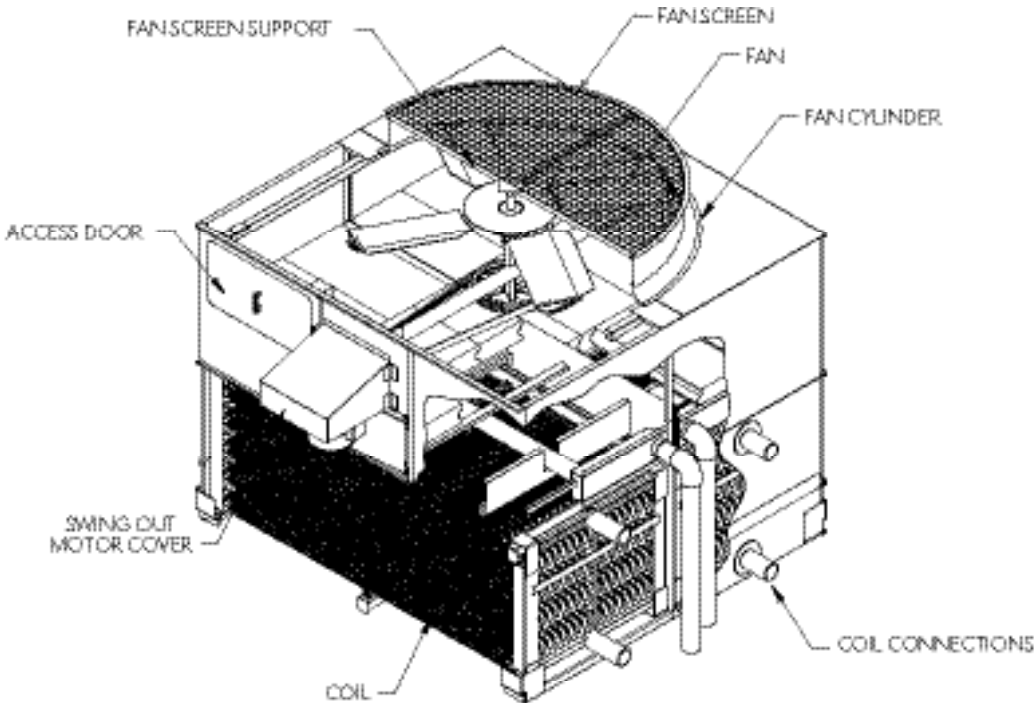




eco-ATC-H and eco-ATWB-H 8.5' Wide Units

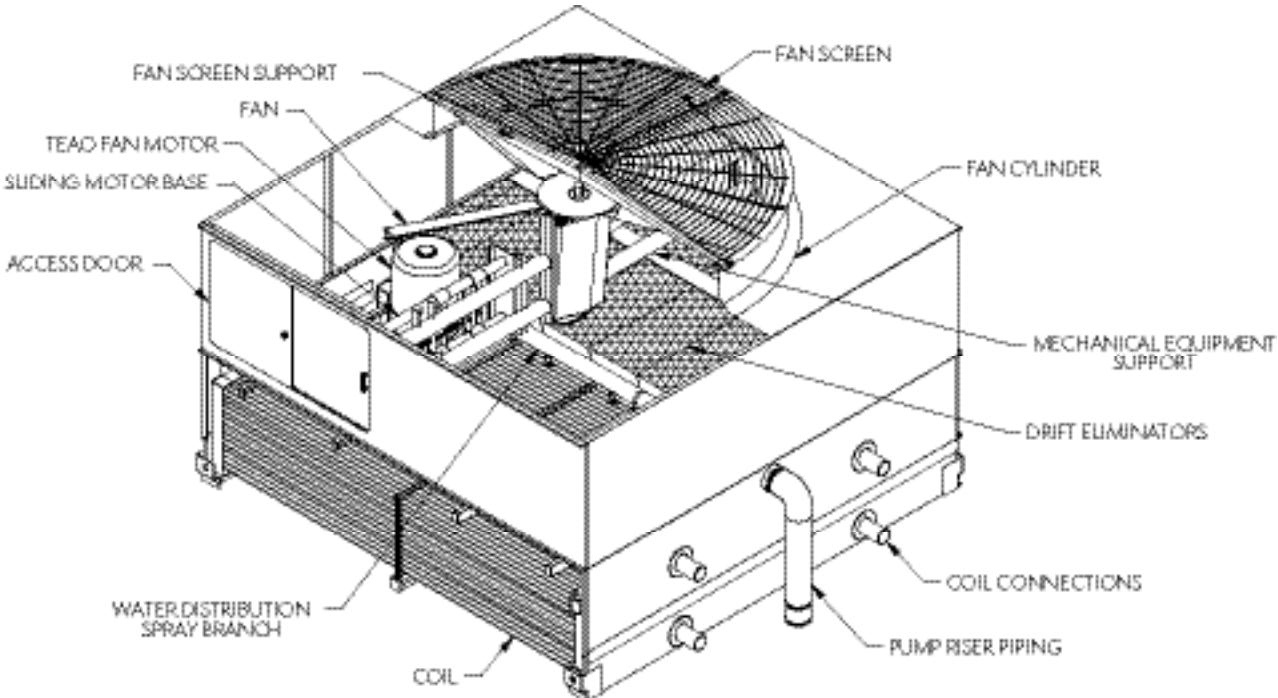


FAN & COIL CASING SECTION

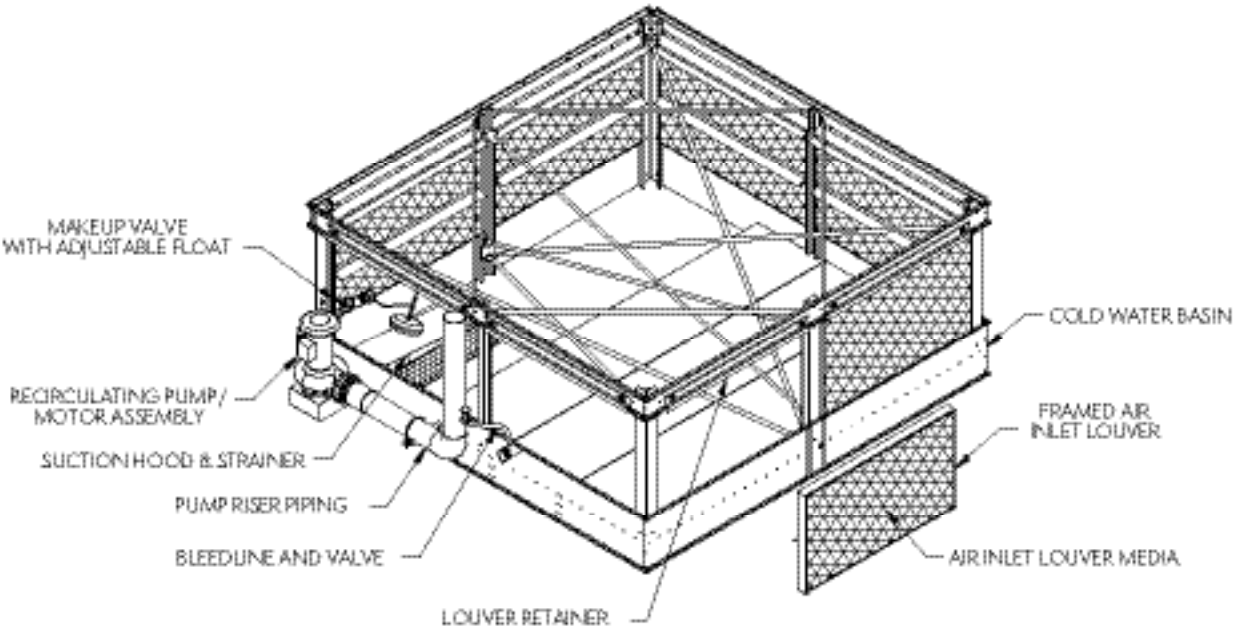


ATC-E/ATWB/eco-ATC-A/eco-ATWB 10' & 12' Wide Units

FAN & COIL CASING SECTION

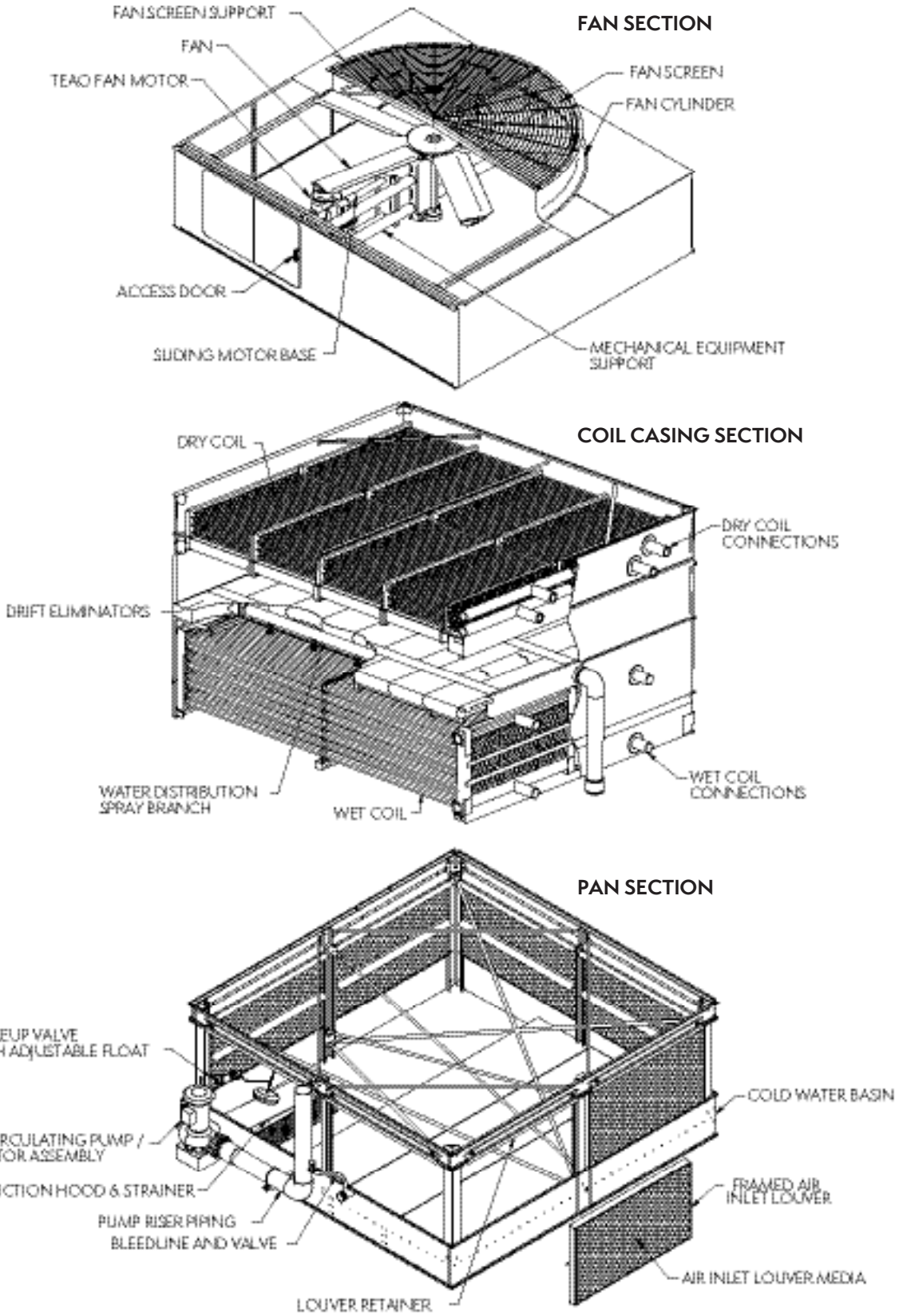


PAN SECTION

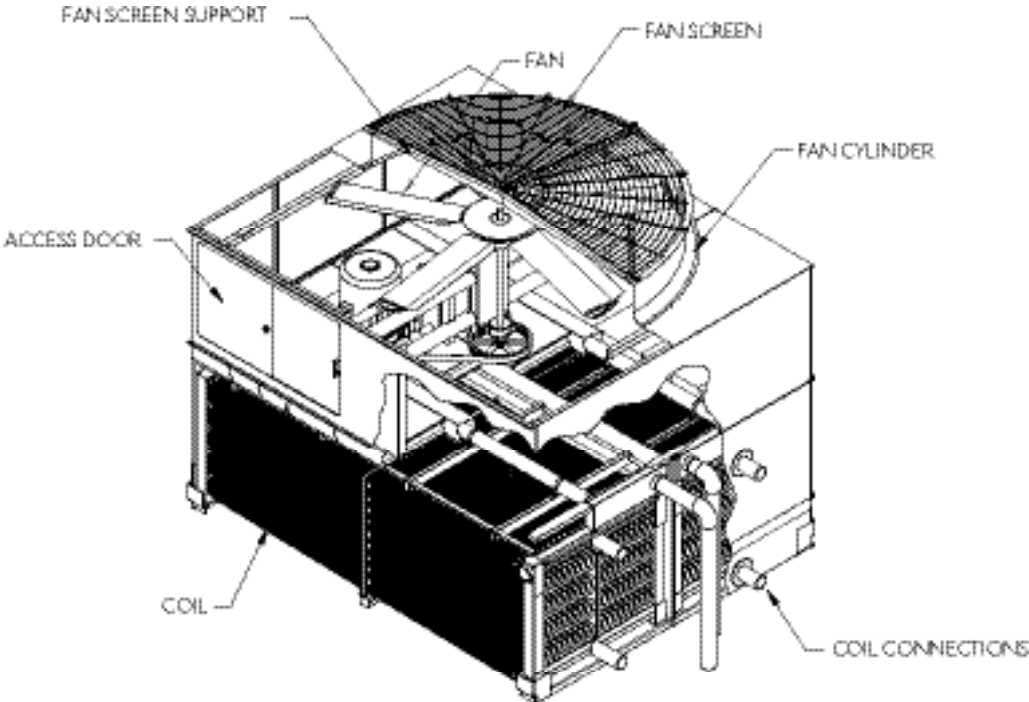




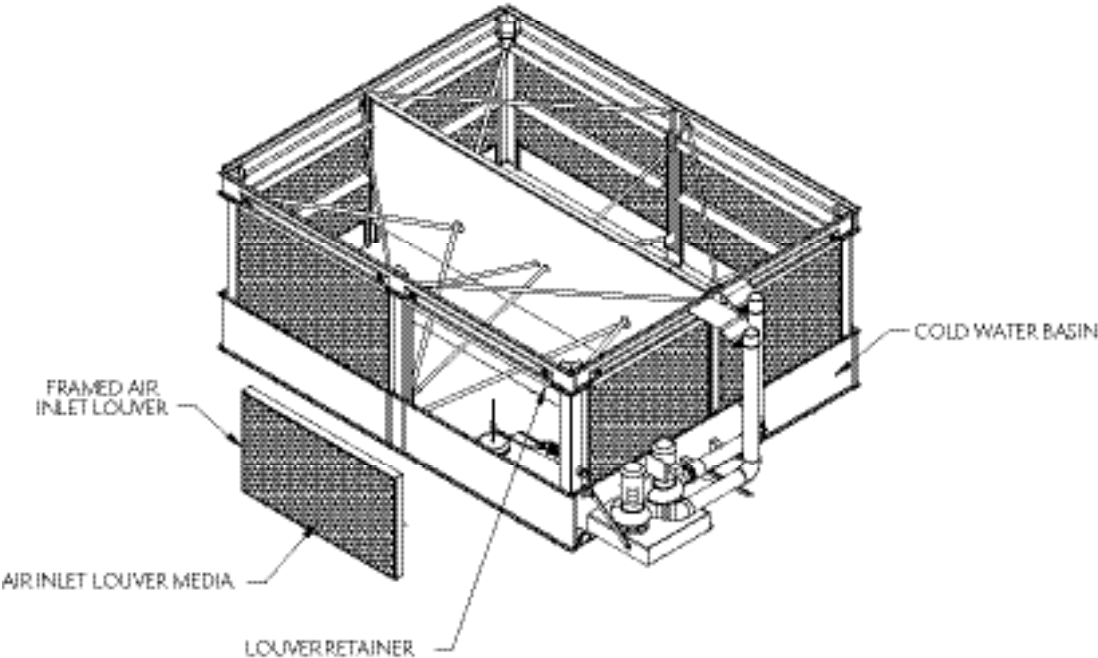
eco-ATC-H / eco-ATWB-H 10' and 12' Wide Units



FAN & COIL CASING SECTION

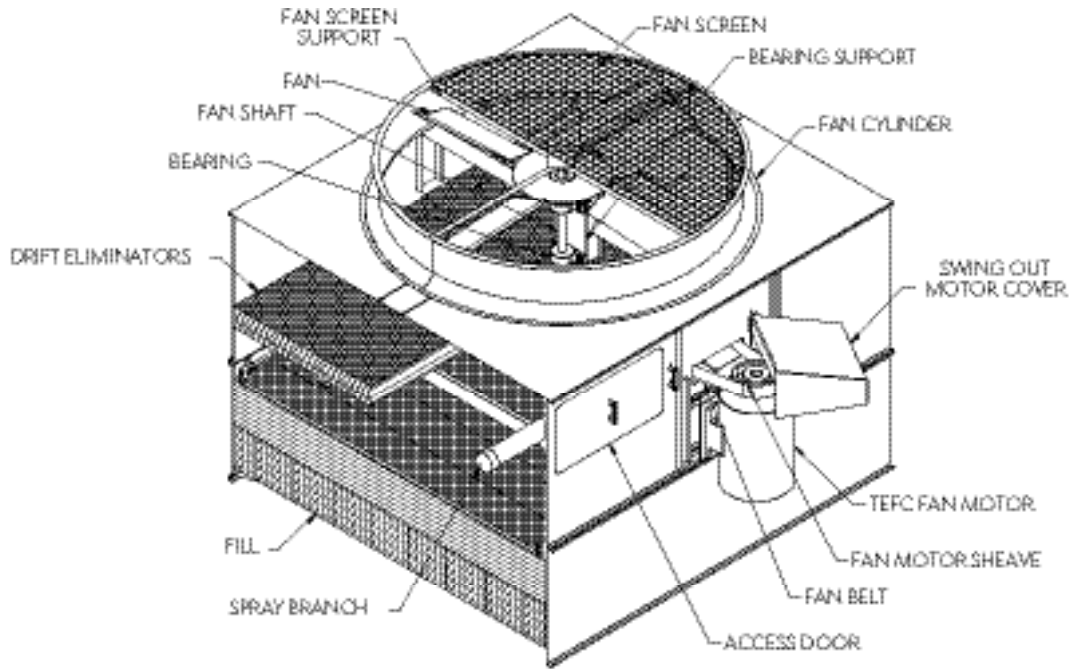


PAN SECTION

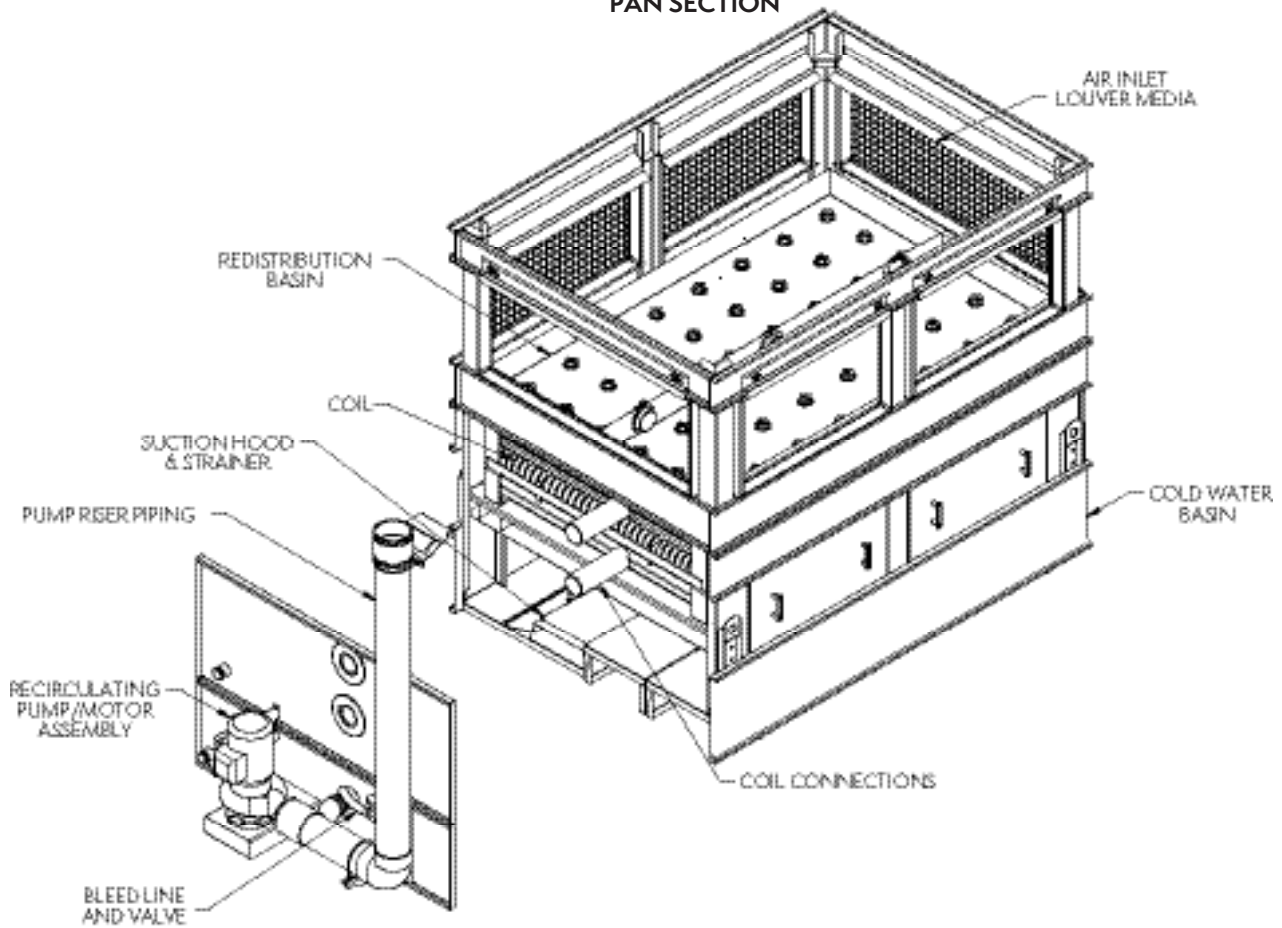


# ESW4 8.5' Wide Units

## FAN & FILL CASING SECTION

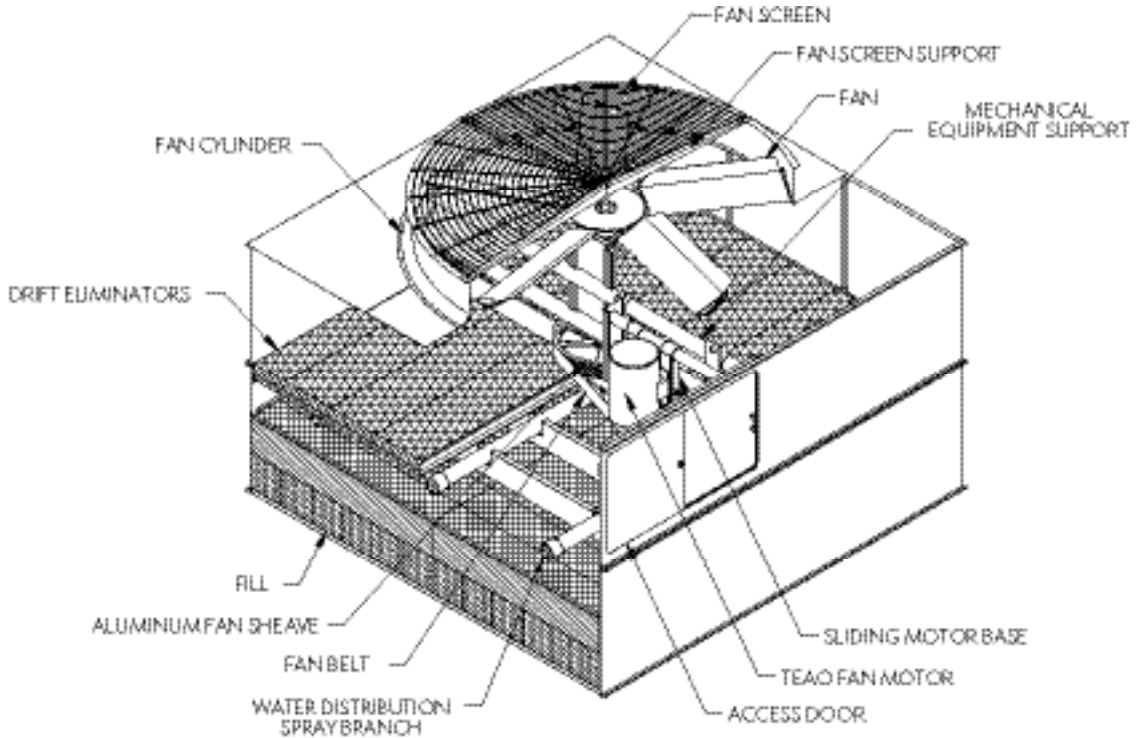


## PAN SECTION

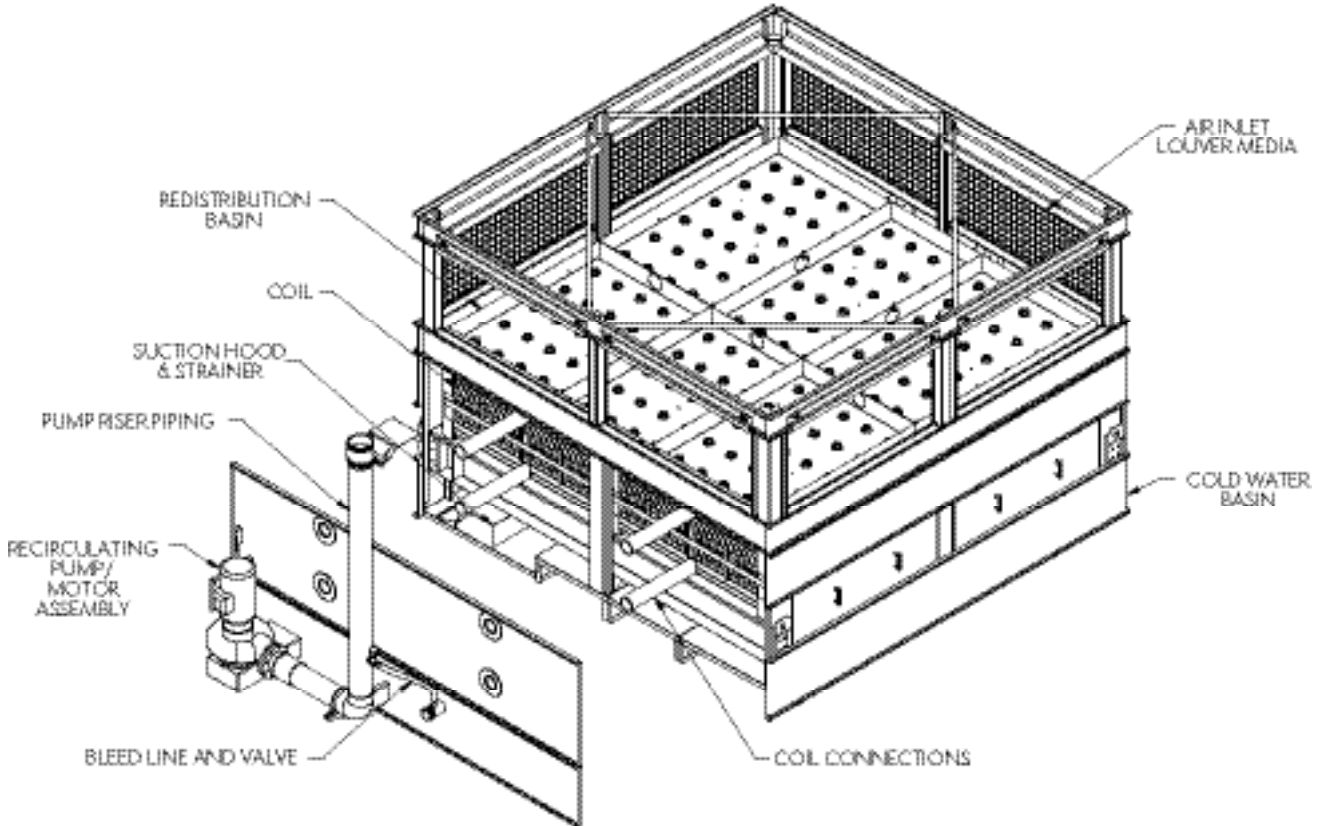


# ESW4 12' Wide Units

## FAN & FILL CASING SECTION



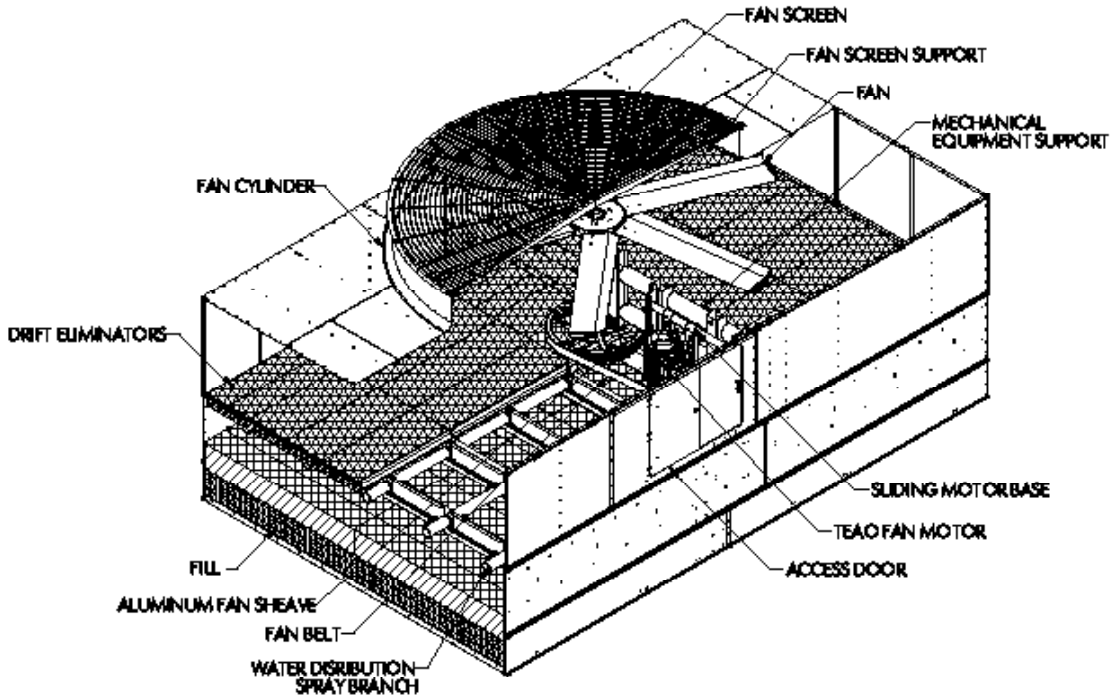
## PAN SECTION



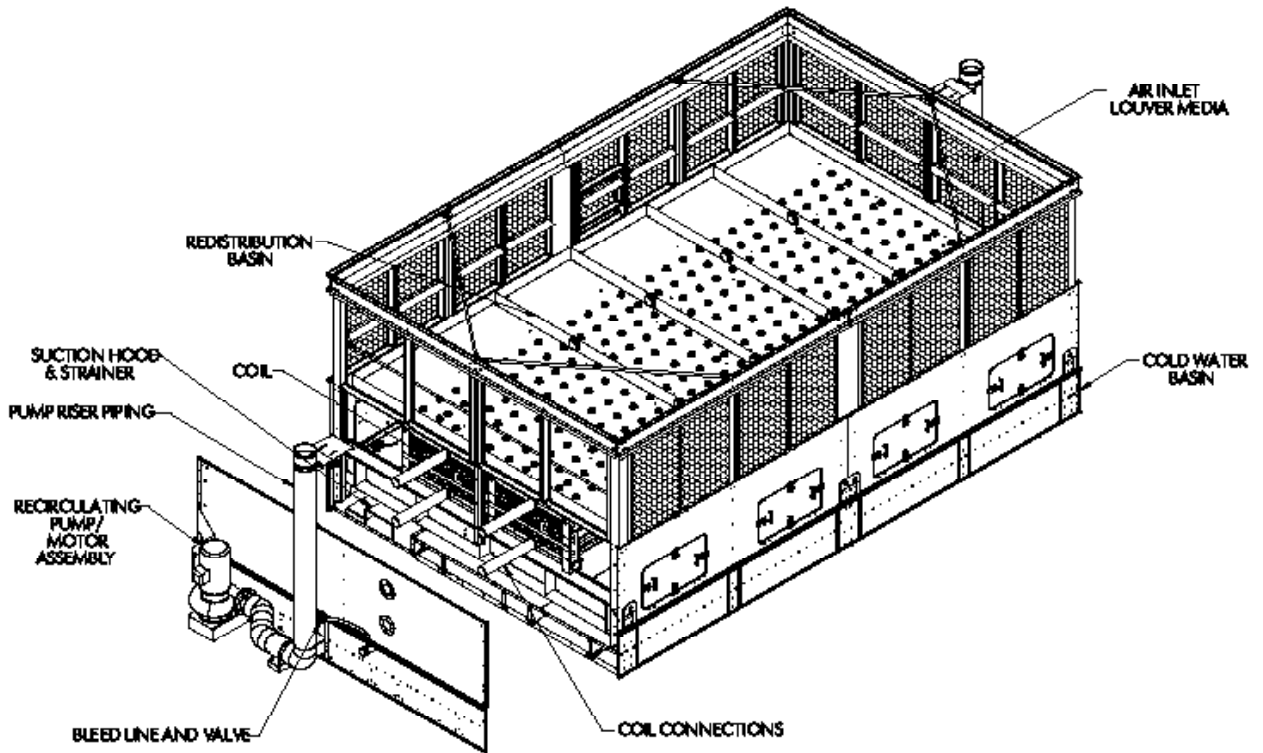


# ESW4 14' Wide Units

## FAN & FILL CASING SECTION

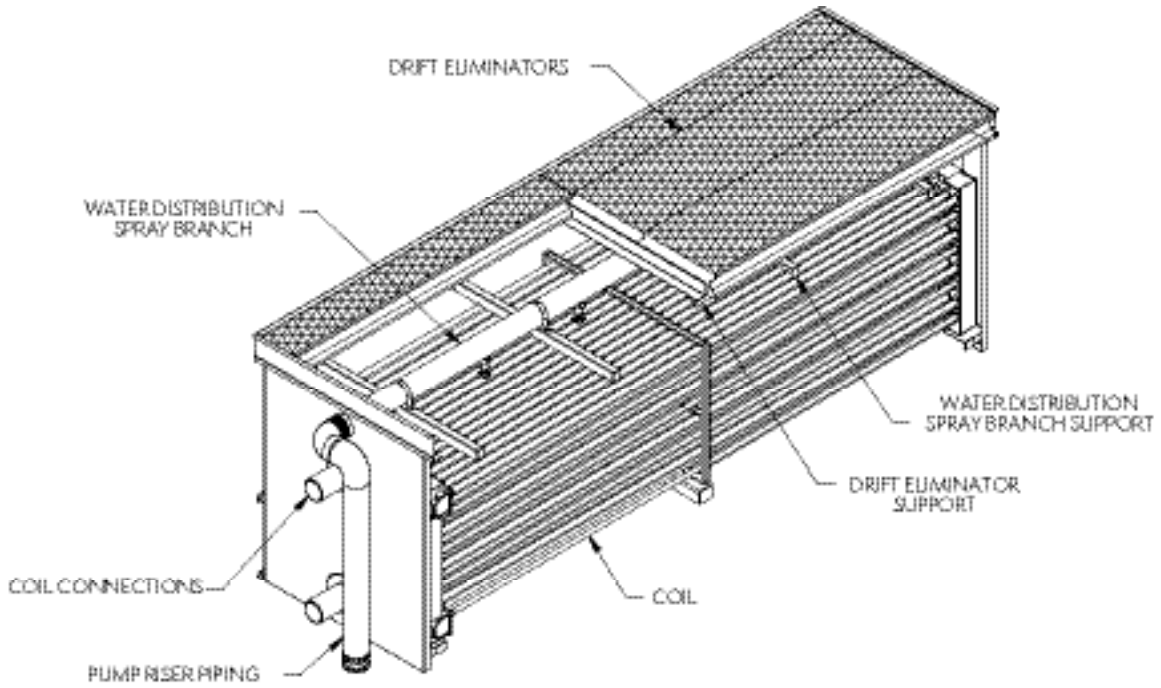


## PAN SECTION

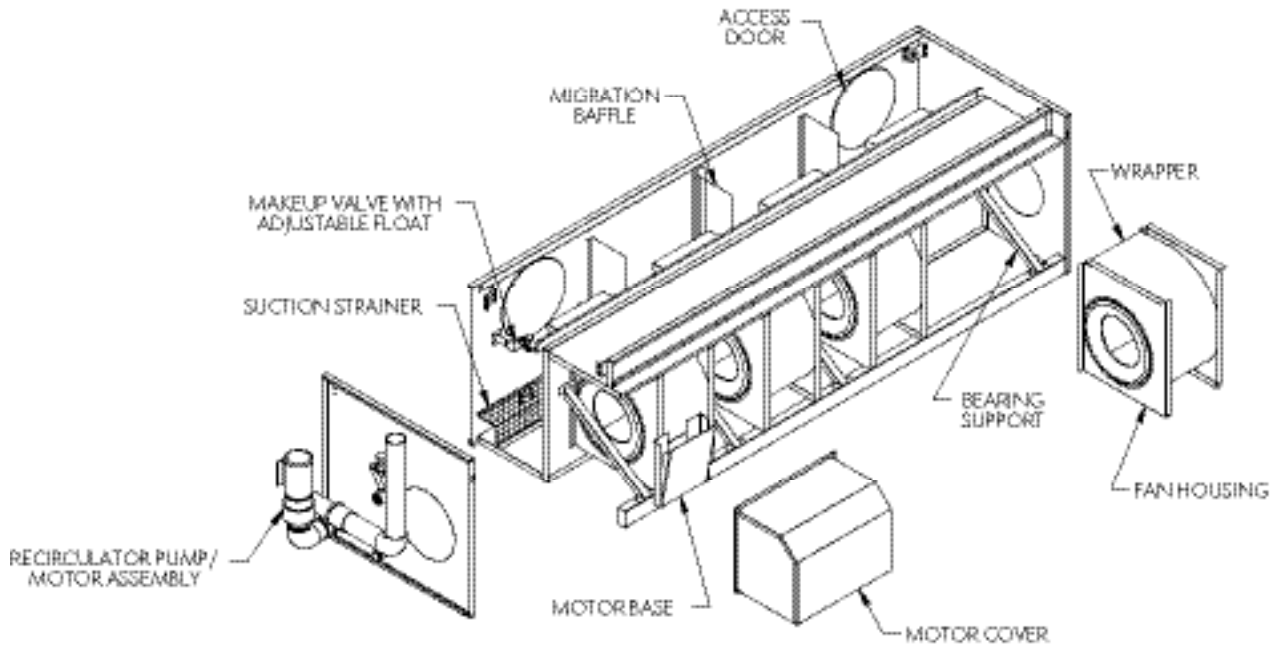


# LSC-E/LSWE/eco-LSWE 4' Wide Units

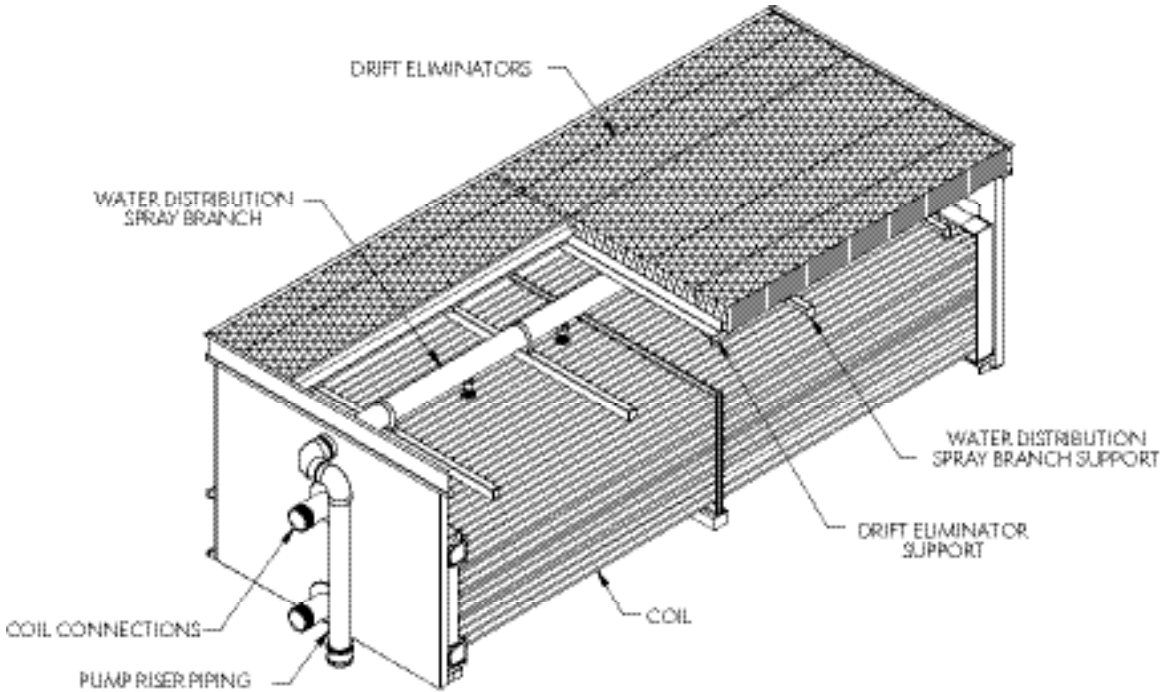
## COIL CASING SECTION



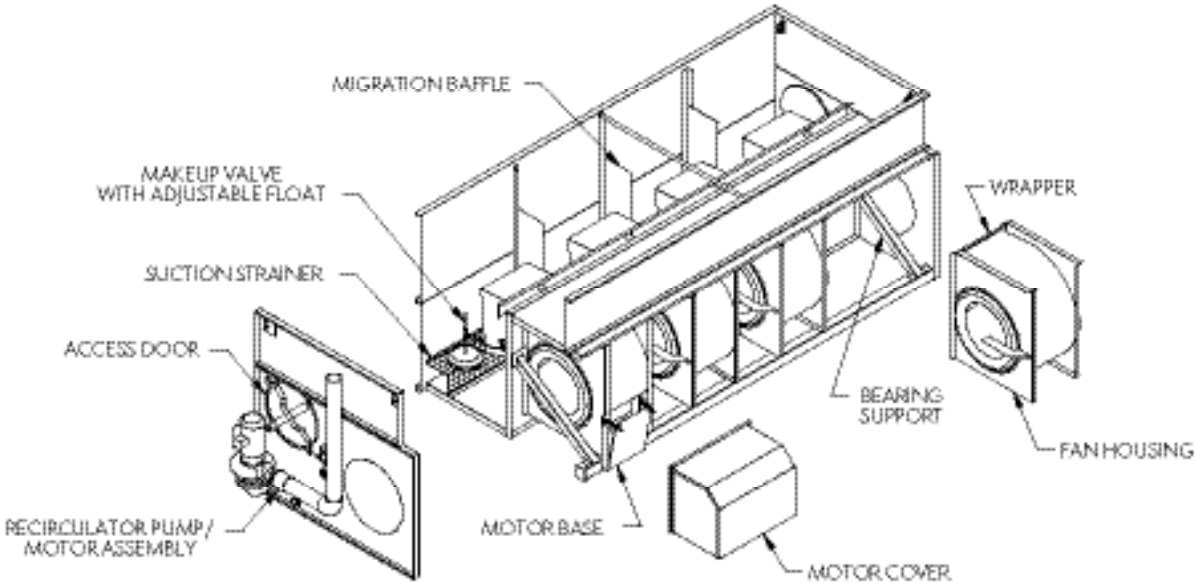
## PAN SECTION



COIL CASING SECTION

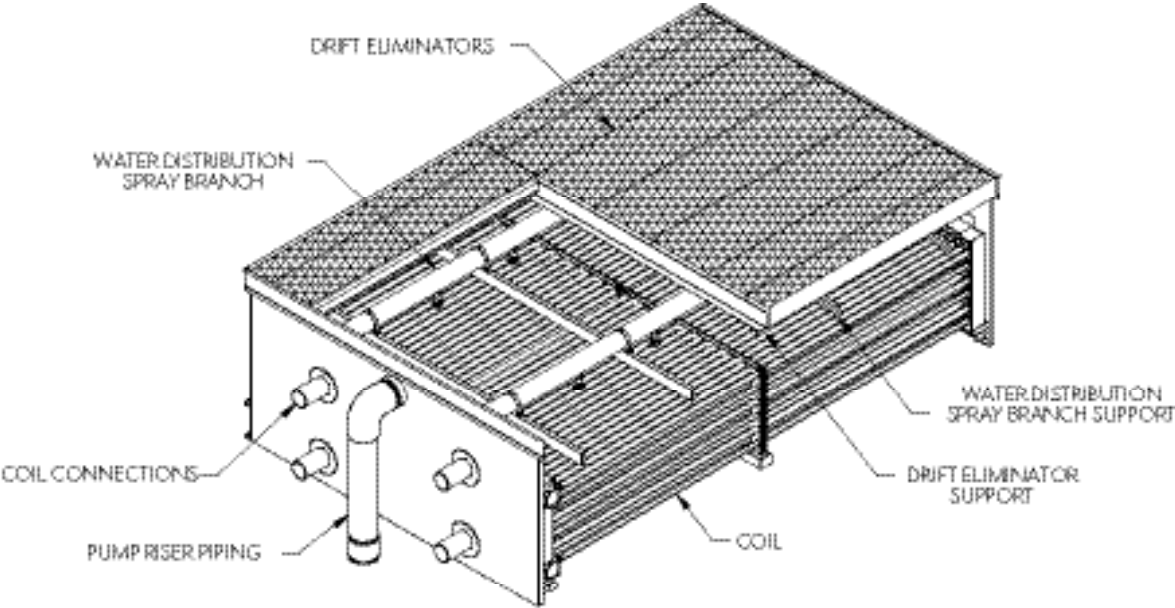


PAN SECTION

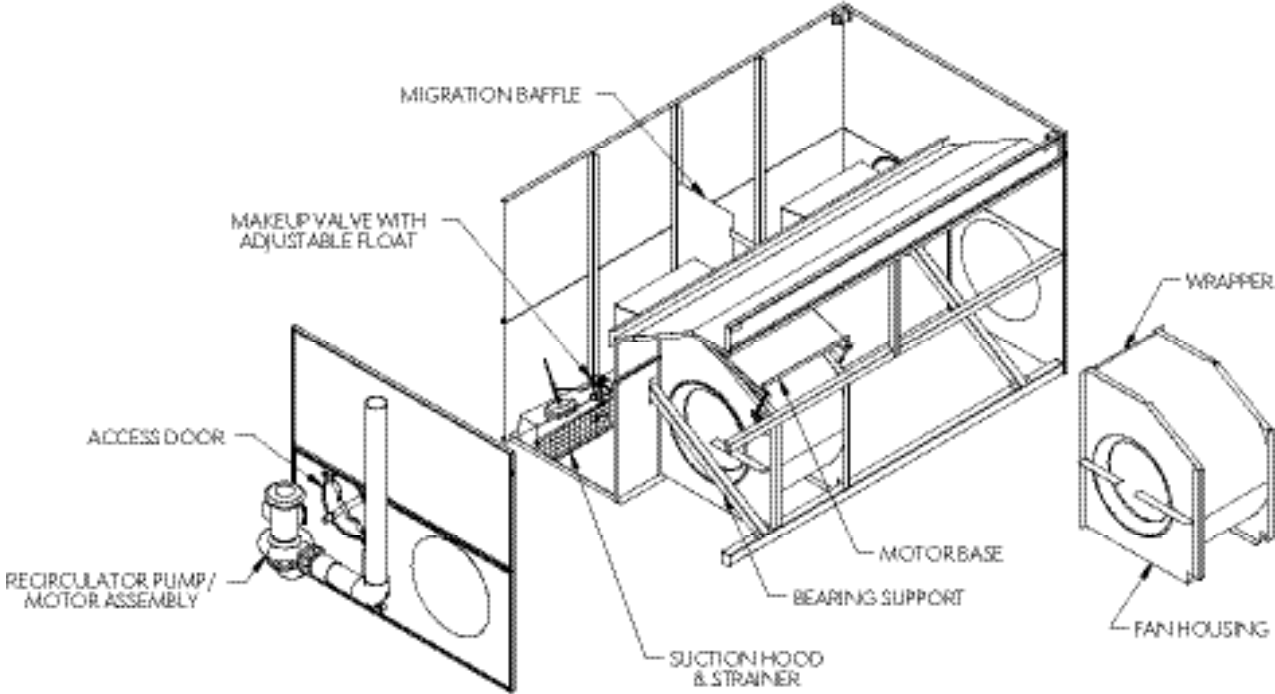


# LSC-E/LSWE/eco-LSWE 8' Wide Units

## COIL CASING SECTION

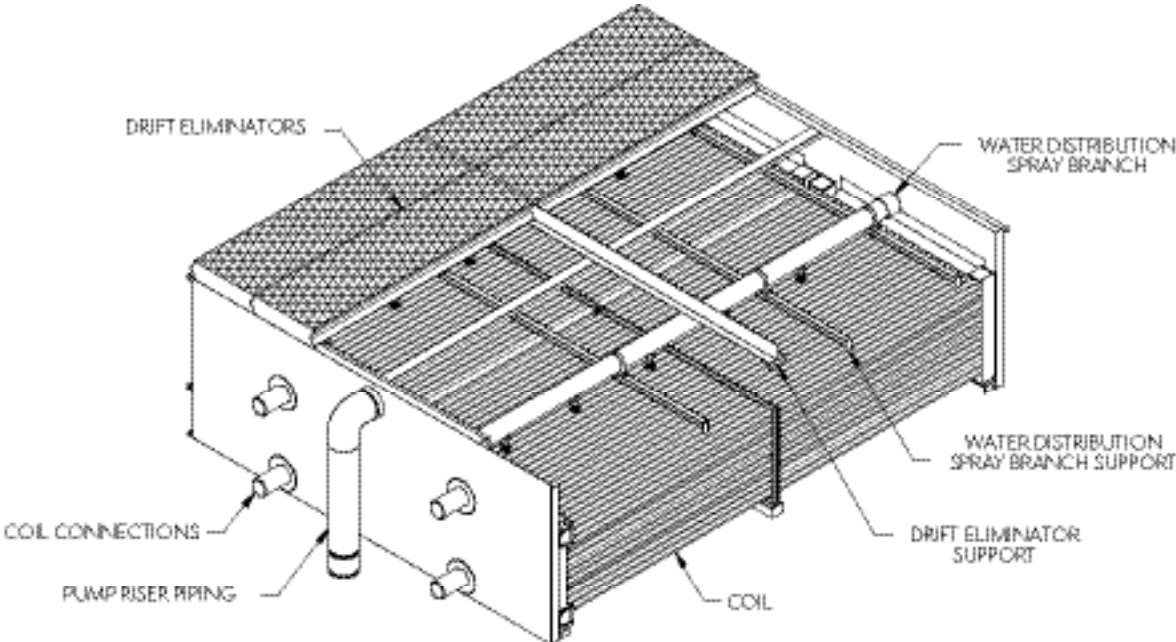


## PAN SECTION

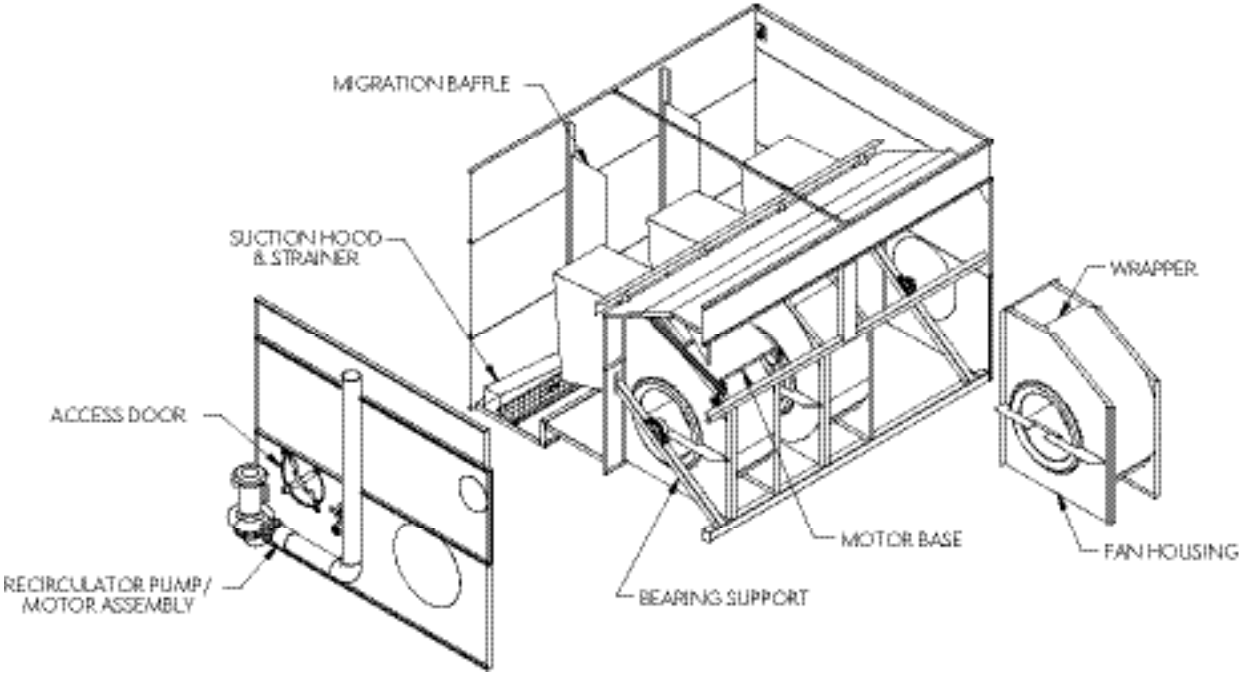




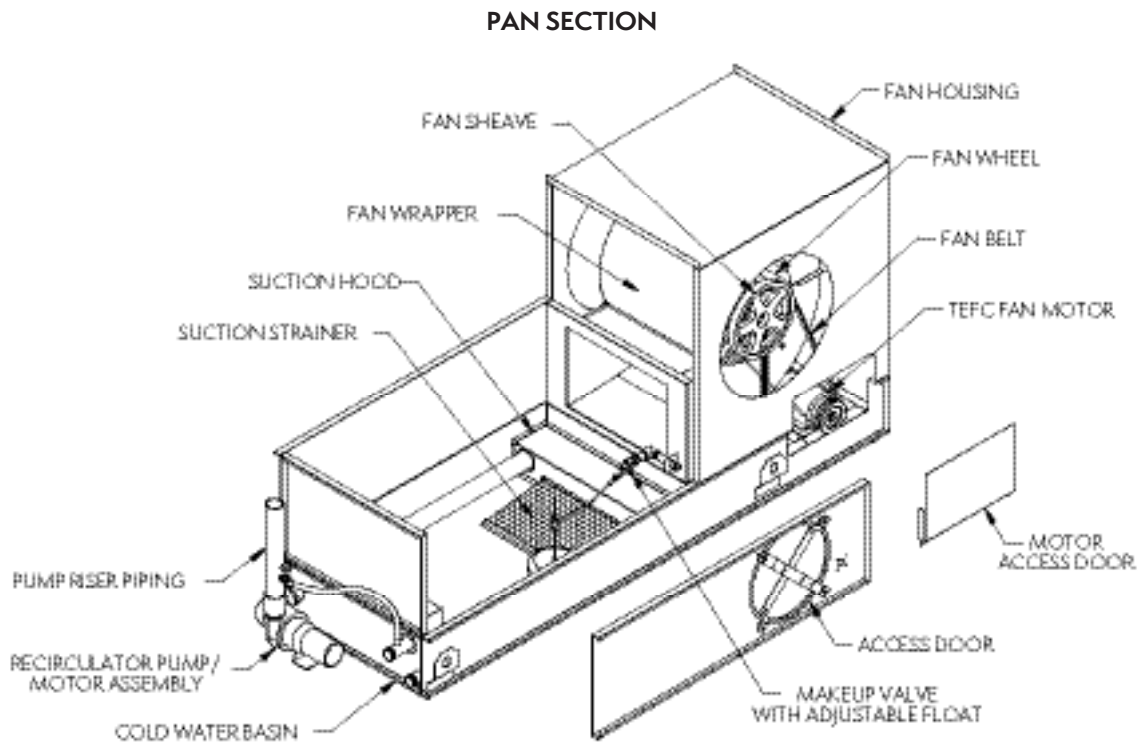
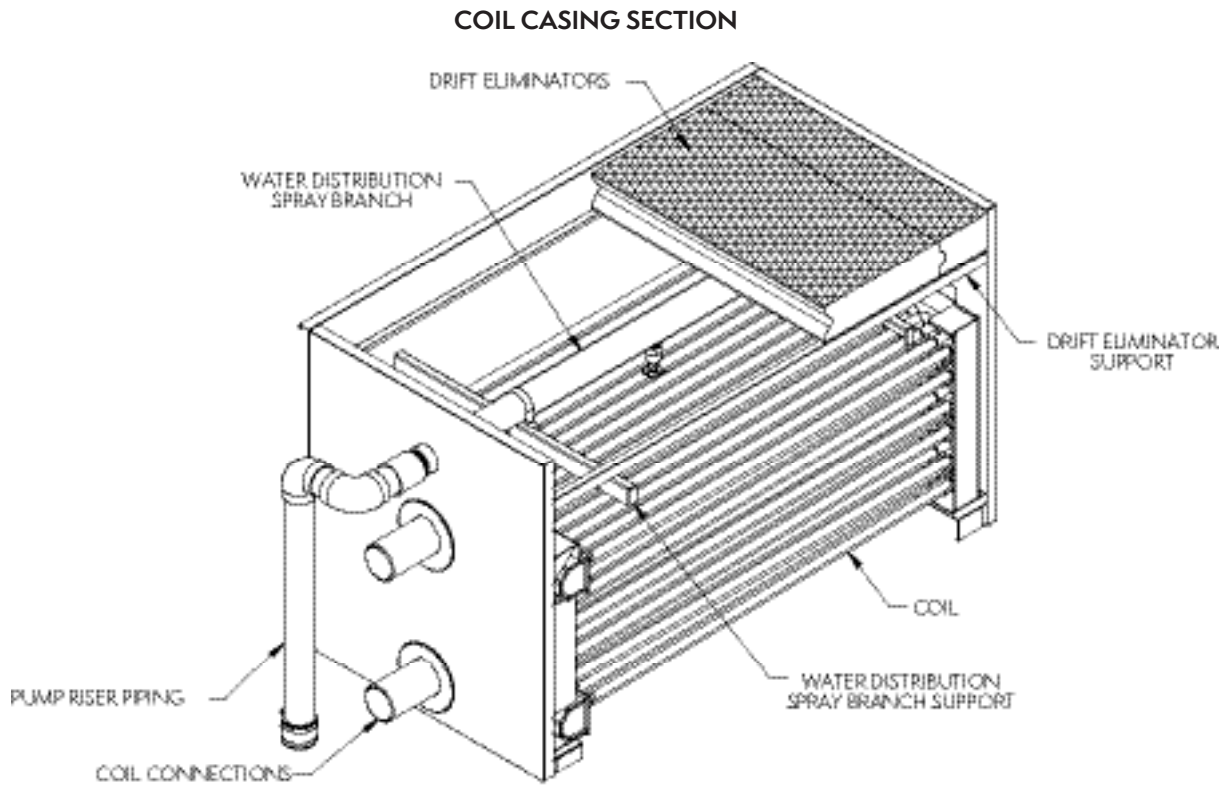
COIL CASING SECTION



PAN SECTION

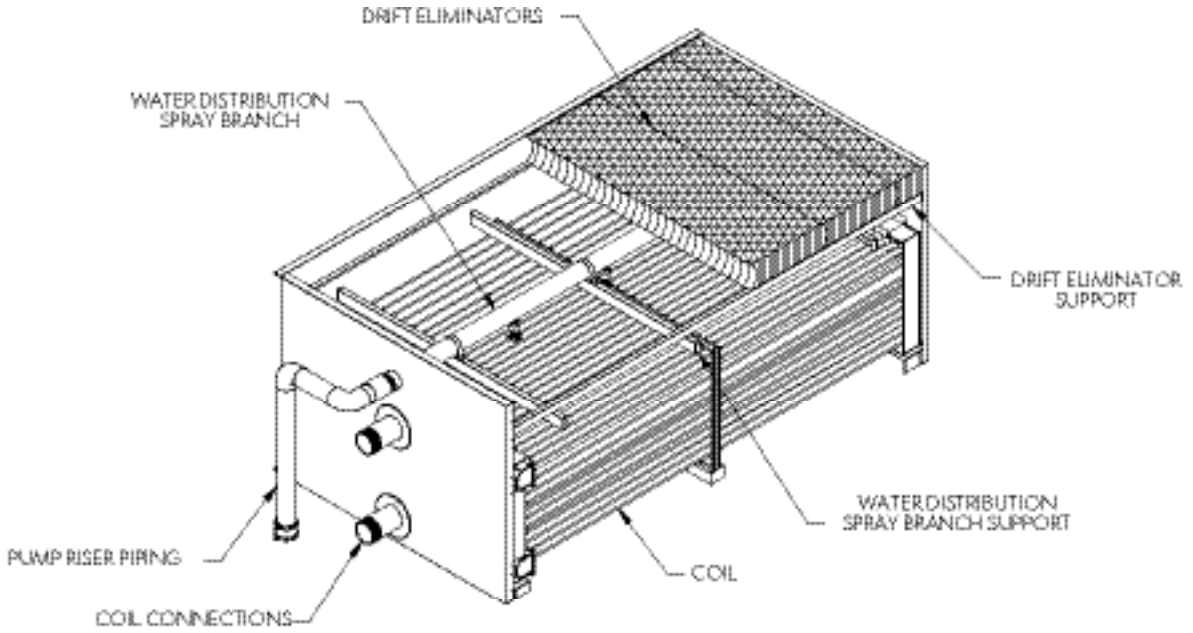


# LRC/LRWB/eco-LRWB 3' Wide Units

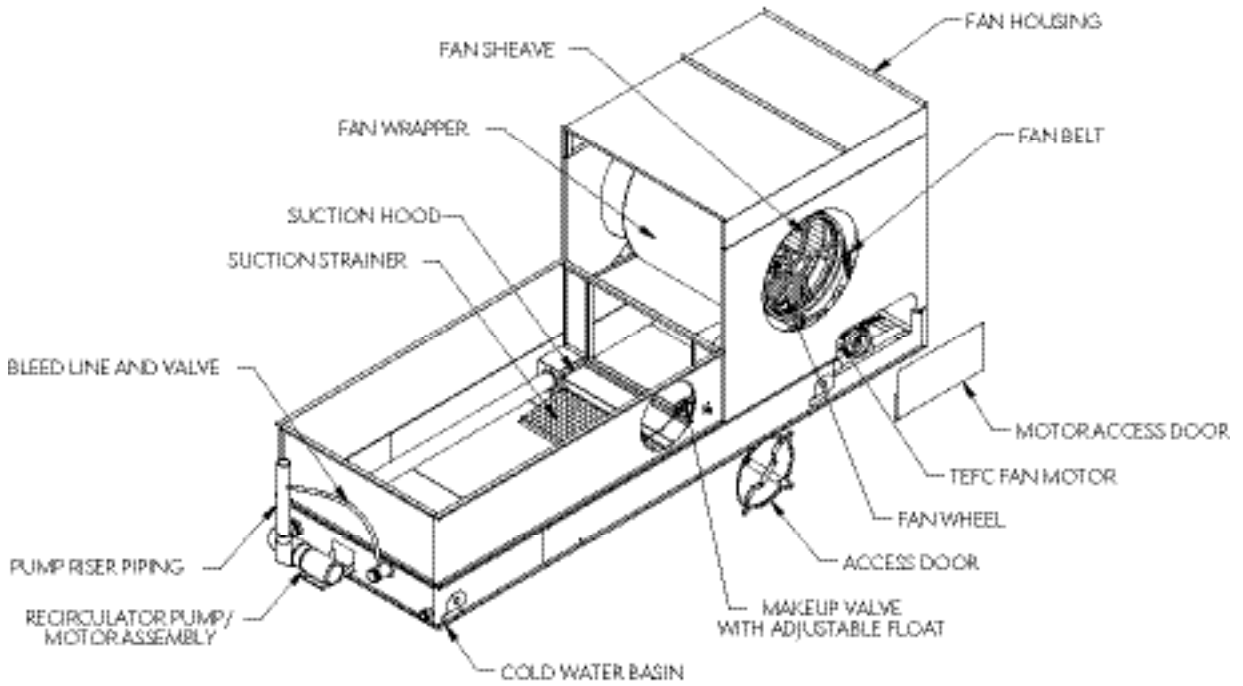


LRC/LRWB/eco-LRWB 5' Wide Units

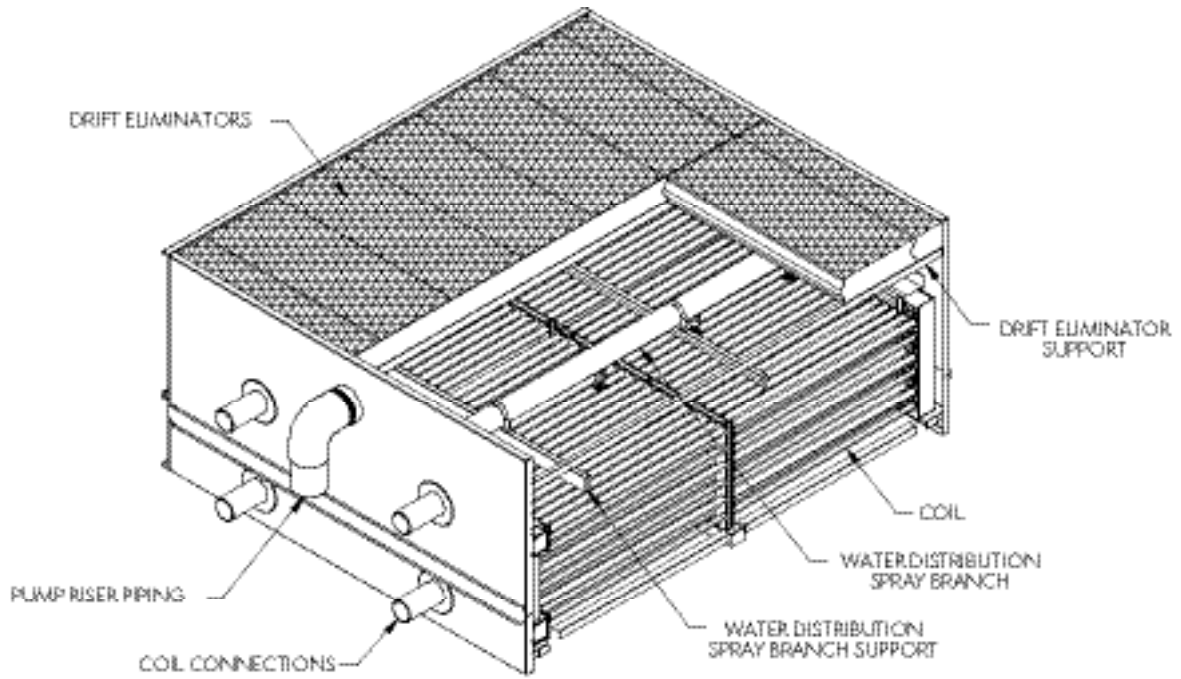
COIL CASING SECTION



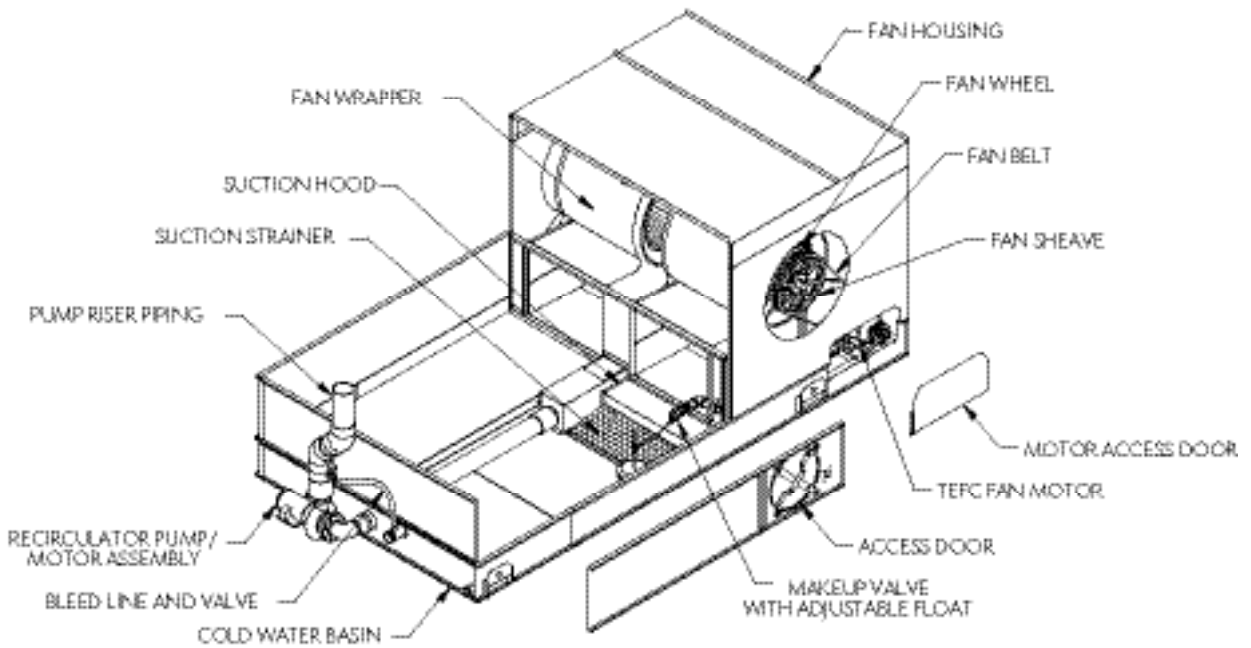
PAN SECTION



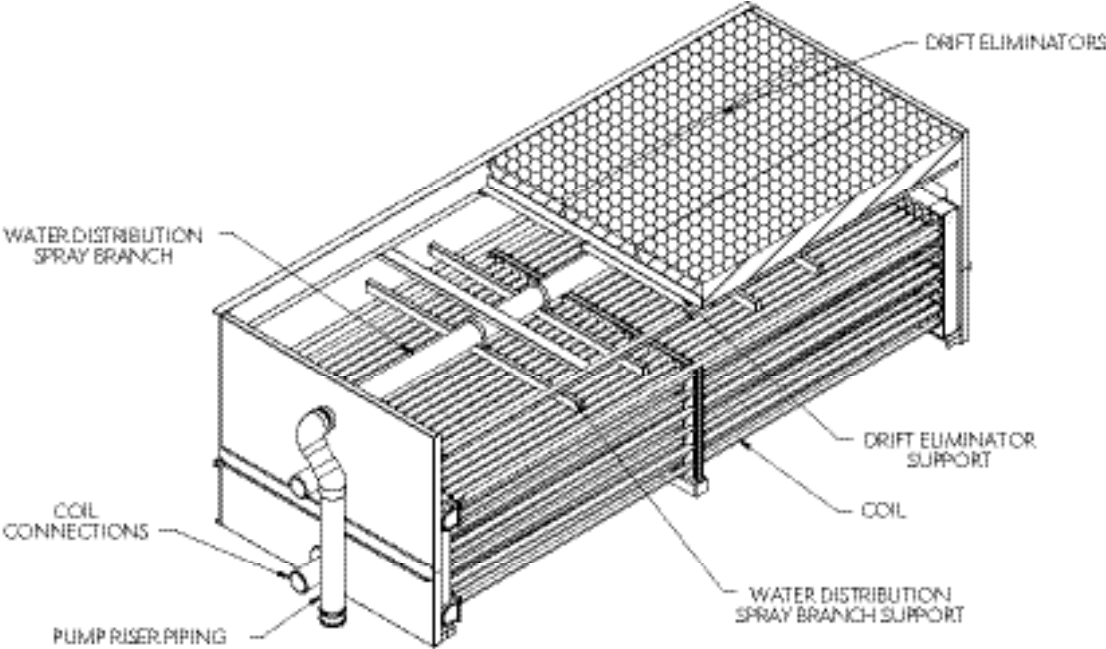
COIL CASING SECTION



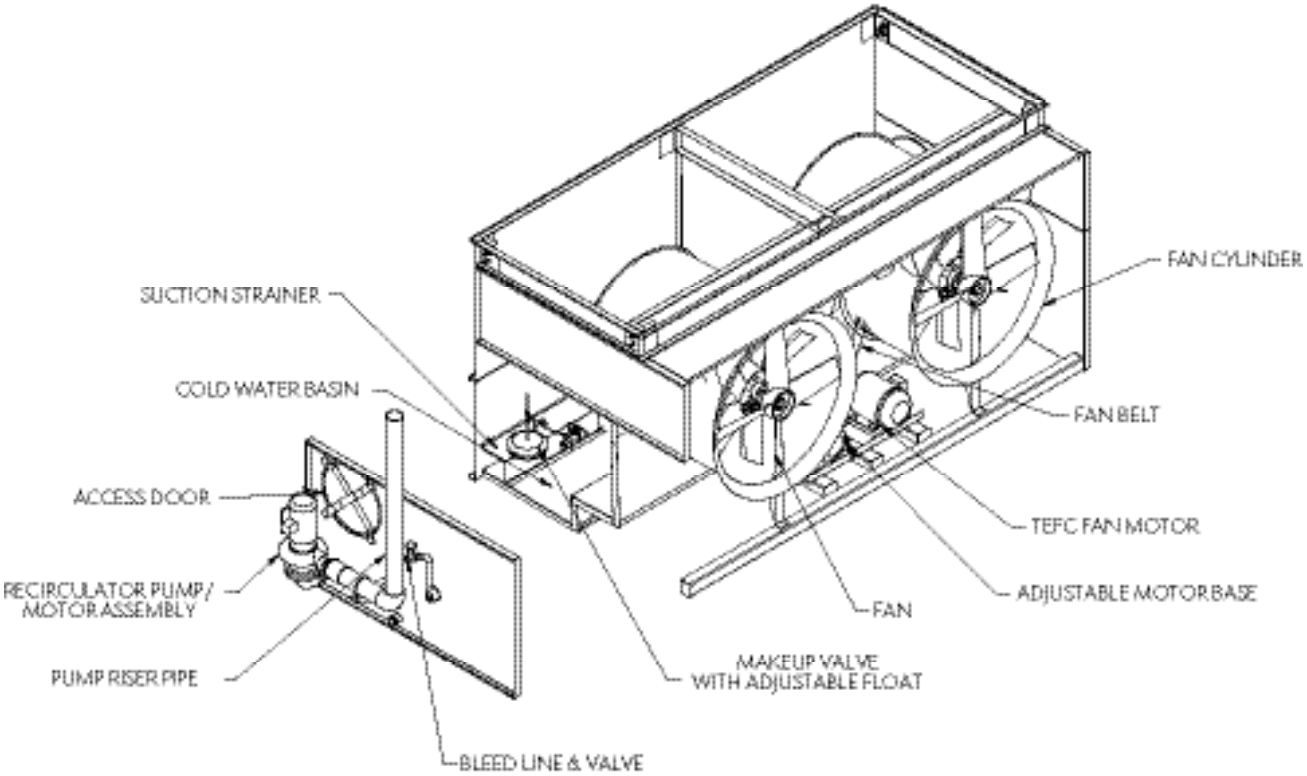
PAN SECTION



COIL CASING SECTION



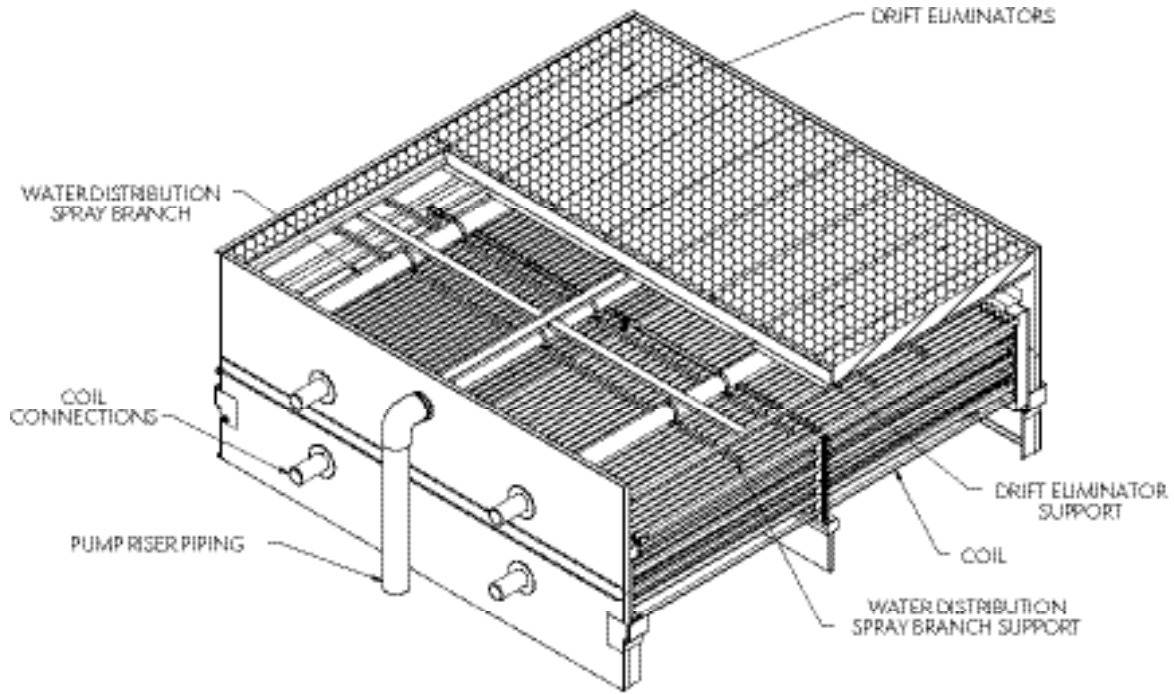
PAN SECTION



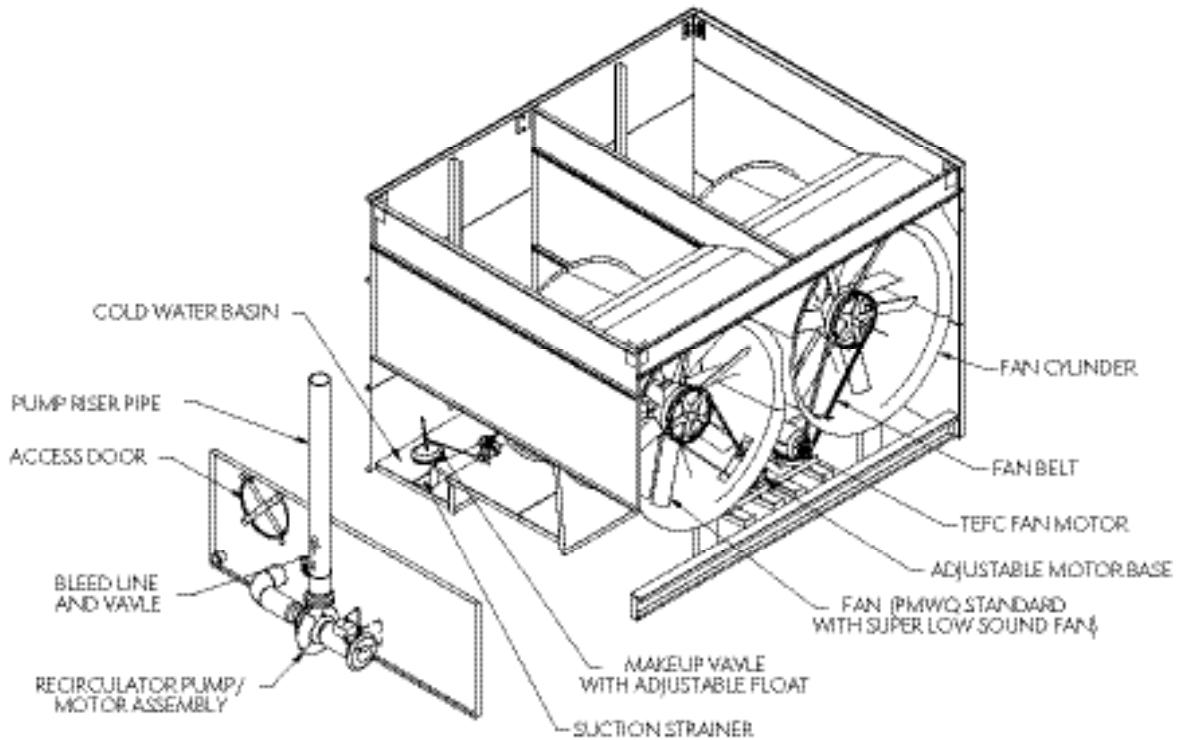


# PMC-E/eco-PMC 10' and 12' Wide Units

## COIL CASING SECTION

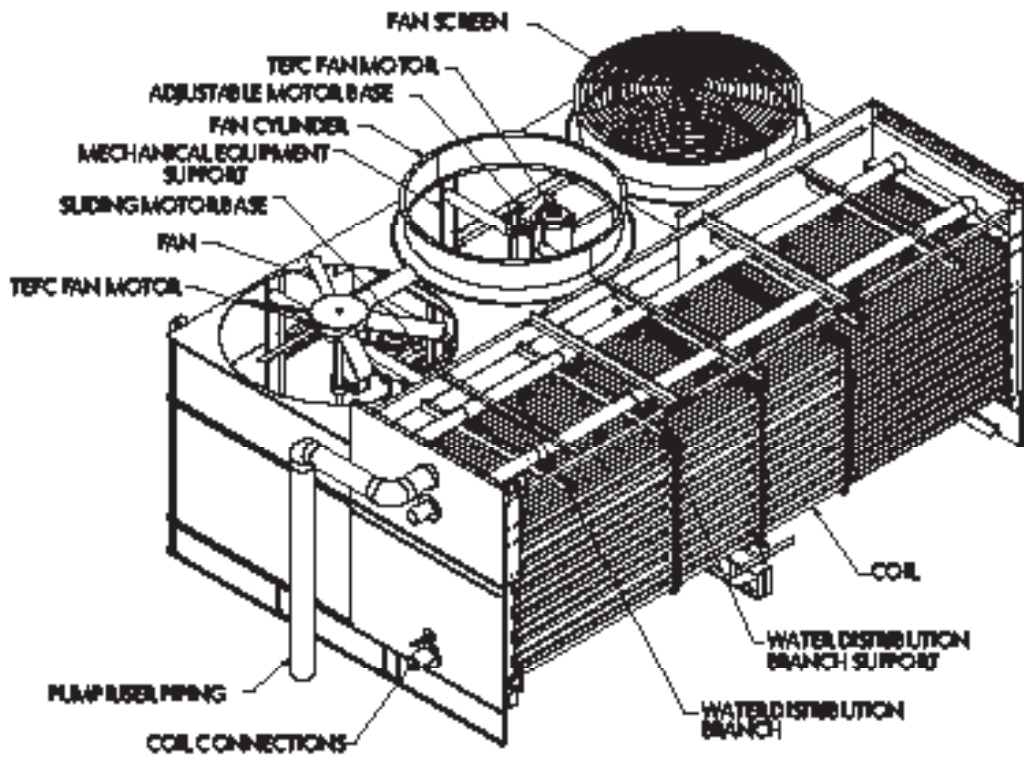


## PAN SECTION

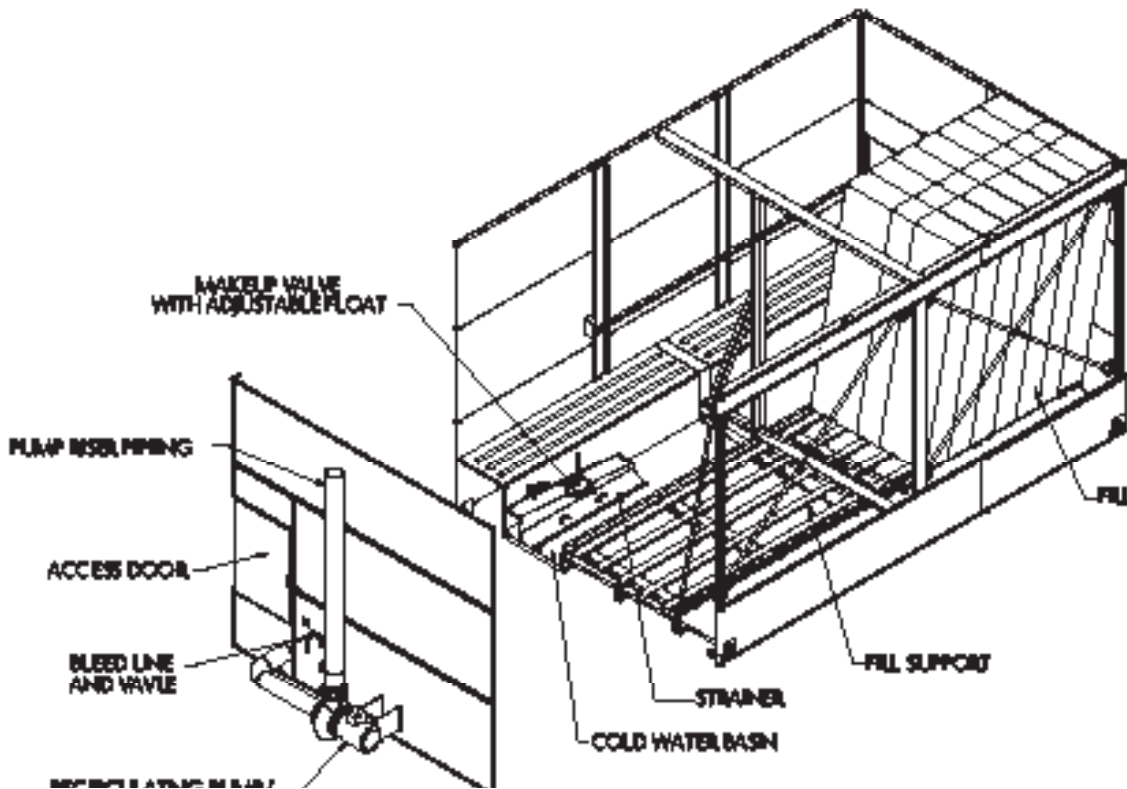


# PHC-S & L 12' Wide-Single Side Air Inlet Units

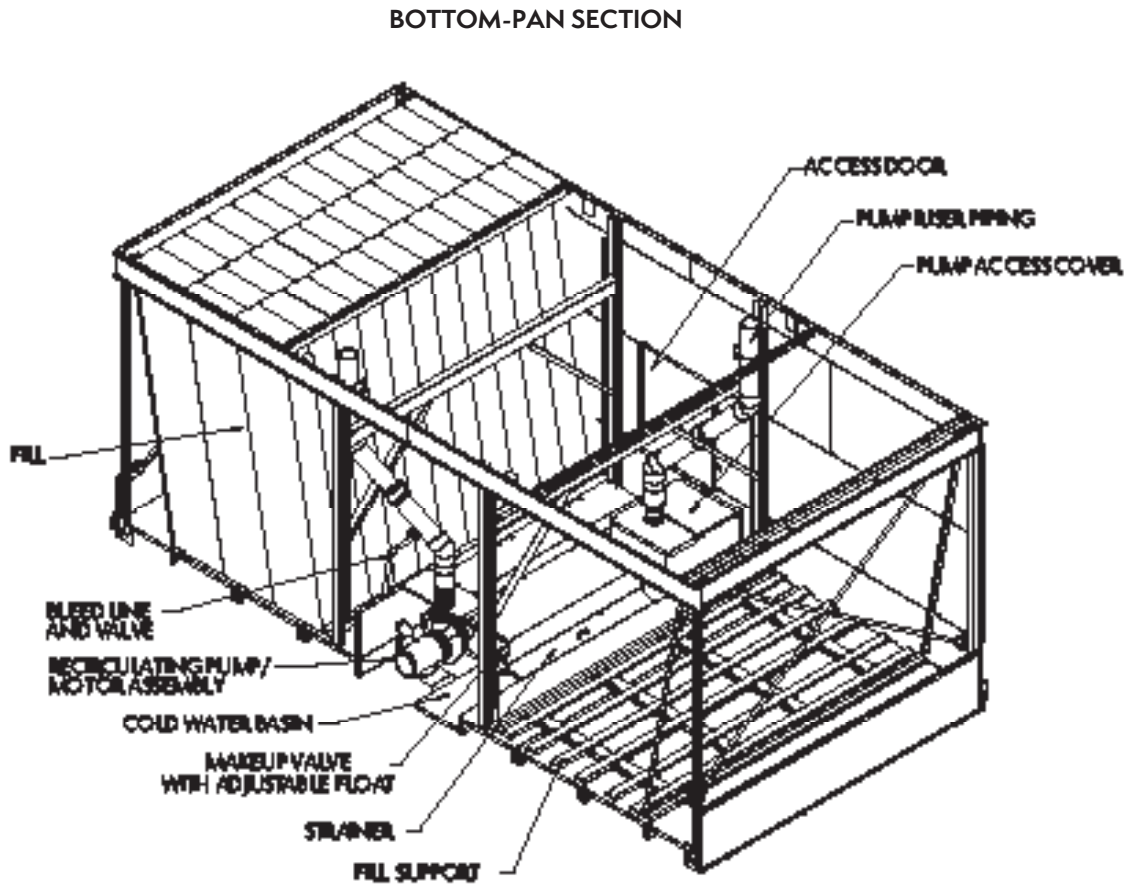
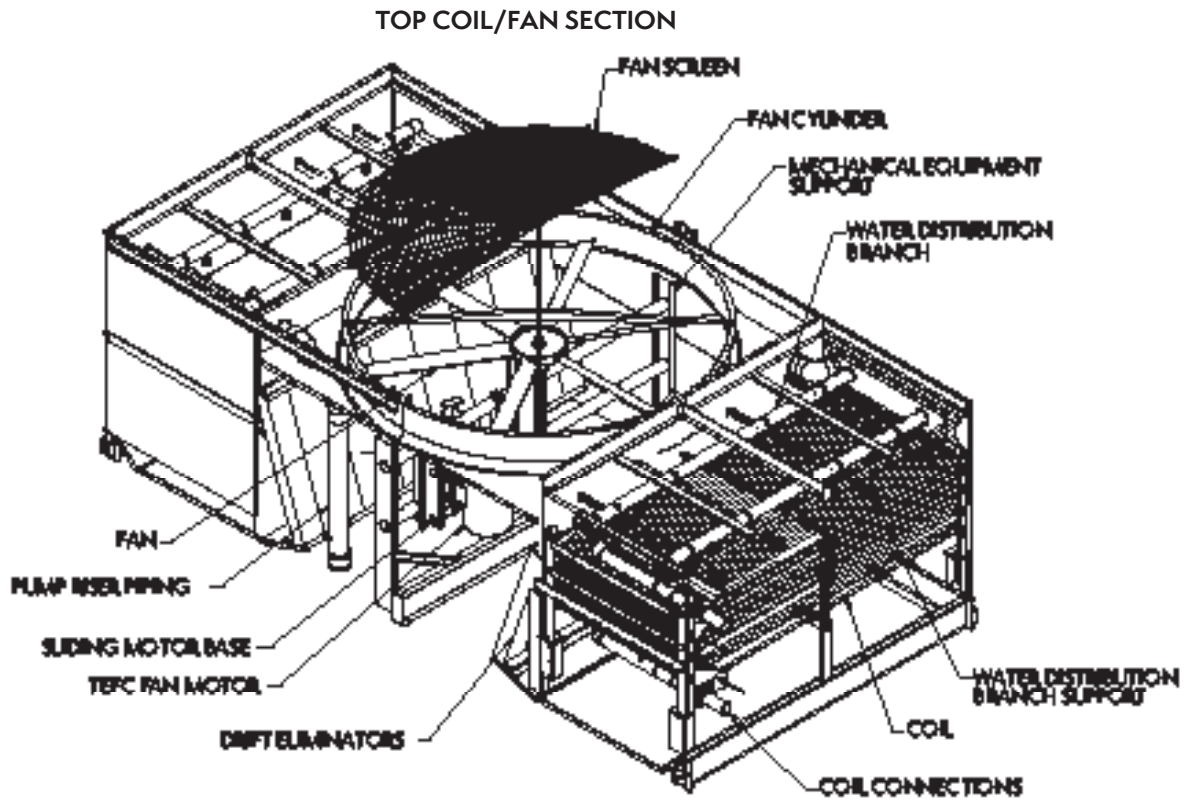
TOP COIL/FAN SECTION



BOTTOM-PAN SECTION



# PHC-D 12' and 14' Wide-Two Sided Air Inlet Units











# WORLDWIDE MANUFACTURING FACILITIES



★ World Headquarters/  
Research and  
Development Center

■ EVAPCO Facilities



## EVAPCO, Inc. — World Headquarters & Research / Development Center

P.O. Box 1300 • Westminster, MD 21158 USA  
410.756.2600 • [marketing@evapco.com](mailto:marketing@evapco.com) • [evapco.com](http://evapco.com)

### North America

**EVAPCO, Inc.**  
**World Headquarters**  
Westminster, MD USA  
410.756.2600  
[marketing@evapco.com](mailto:marketing@evapco.com)

**EVAPCO East**  
Taneytown, MD USA  
410.756.2600  
[marketing@evapco.com](mailto:marketing@evapco.com)

**EVAPCO East**  
Key Building  
Taneytown, MD USA  
410.756.2600  
[marketing@evapco.com](mailto:marketing@evapco.com)

**EVAPCO Midwest**  
Greenup, IL USA  
217.923.3431  
[evapcomw@evapcomw.com](mailto:evapcomw@evapcomw.com)

**EVAPCO West**  
Madera, CA USA  
559.673.2207  
[contact@evapcowest.com](mailto:contact@evapcowest.com)

**EVAPCO Iowa**  
Lake View, IA USA  
712.657.3223

**EVAPCO Iowa**  
Sales & Engineering  
Medford, MN USA  
507.446.8005  
[evapcomn@evapcomn.com](mailto:evapcomn@evapcomn.com)

**EVAPCO Newton**  
Newton, IL USA  
618.783.3433  
[evapcomw@evapcomw.com](mailto:evapcomw@evapcomw.com)

3M/12-20/DGD

Bulletin CLR190M

**Evapcold Manufacturing**  
Greenup, IL USA  
217.923.3431  
[evapcomw@evapcomw.com](mailto:evapcomw@evapcomw.com)

**EVAPCO Dry Cooling, Inc.**  
Littleton, CO USA  
908.895.3236  
[info@evapcodc.com](mailto:info@evapcodc.com)  
Spare Parts: 908.895.3236  
Spare Parts: [spares@evapcodc.com](mailto:spares@evapcodc.com)

**EVAPCO Dry Cooling, Inc.**  
Bridgewater, NJ USA  
908.379.2665  
[info@evapcodc.com](mailto:info@evapcodc.com)

**EVAPCO Power México S. de R.L. de C.V.**  
Mexico City, Mexico  
(52) 55.8421.9260  
[info@evapcodc.com](mailto:info@evapcodc.com)

**Refrigeration Vessels & Systems Corporation**  
*A wholly owned subsidiary of EVAPCO, Inc.*  
Bryan, TX USA  
979.778.0095  
[rvs@rvscorp.com](mailto:rvs@rvscorp.com)

**EvapTech, Inc.**  
*A wholly owned subsidiary of EVAPCO, Inc.*  
Edwardsville, KS USA  
913.322.5165  
[marketing@evaptech.com](mailto:marketing@evaptech.com)

**Tower Components, Inc.**  
*A wholly owned subsidiary of EVAPCO, Inc.*  
Ramseur, NC USA  
336.824.2102  
[mail@towercomponentsinc.com](mailto:mail@towercomponentsinc.com)

**EVAPCO Alcoil, Inc.**  
*A wholly owned subsidiary of EVAPCO, Inc.*  
York, PA USA  
717.347.7500  
[info@evapco-alcoil.com](mailto:info@evapco-alcoil.com)

### Europe

**EVAPCO Europe BVBA**  
**European Headquarters**  
Tongeren, Belgium  
(32) 12.39.50.29  
[evapco.europe@evapco.be](mailto:evapco.europe@evapco.be)

**EVAPCO Europe, S.r.l.**  
Milan, Italy  
(39) 02.939.9041  
[evapco.europe@evapco.it](mailto:evapco.europe@evapco.it)

**EVAPCO Europe, S.r.l.**  
Sondrio, Italy

**EVAPCO Europe GmbH**  
Meerbusch, Germany  
(49) 2159.69560  
[info@evapco.de](mailto:info@evapco.de)

**EVAPCO Air Solutions**  
*A wholly owned subsidiary of EVAPCO, Inc.*  
Aabybro, Denmark  
(45) 9824.4999  
[info@evapco.dk](mailto:info@evapco.dk)

**EVAPCO Air Solutions GmbH**  
Garbsen, Germany  
(49) 5137.938750  
[info@evapcoas.de](mailto:info@evapcoas.de)

**Evap Egypt Engineering Industries Co.**  
*A licensed manufacturer of EVAPCO, Inc.*  
Nasr City, Cairo, Egypt  
(202) 24044997 / (202) 24044998  
[mmanz@tiba-group.com](mailto:mmanz@tiba-group.com) /  
[hany@tiba-group.com](http://hany@tiba-group.com)

**EVAPCO Middle East DMCC**  
Dubai, United Arab Emirates  
(971) 4.448.7242  
[info@evapco.ae](mailto:info@evapco.ae)

**EVAPCO S.A. (Pty.) Ltd.**  
*A licensed manufacturer of EVAPCO, Inc.*  
Isando, South Africa  
(27) 11.392.6630  
[evapco@evapco.co.za](mailto:evapco@evapco.co.za)

### Asia Pacific

**EVAPCO Asia Pacific Headquarters**  
Baoshan Industrial Zone  
Shanghai, P.R. China  
(86) 21.6687.7786  
[marketing@evapcochina.com](mailto:marketing@evapcochina.com)

**EVAPCO (Shanghai) Refrigeration Equipment Co., Ltd.**  
Baoshan Industrial Zone, Shanghai, P.R. China  
(86) 21.6687.7786  
[marketing@evapcochina.com](mailto:marketing@evapcochina.com)

**EVAPCO (Beijing) Refrigeration Equipment Co., Ltd.**  
Huairou District, Beijing, P.R. China  
(86) 10.6166.7238  
[marketing@evapcochina.com](mailto:marketing@evapcochina.com)

**EVAPCO Air Cooling Systems (Jiaxing) Company, Ltd.**  
Jiaxing, Zhejiang, P.R. China  
(86) 573.8311.9379  
[info@evapcochina.com](mailto:info@evapcochina.com)

**EVAPCO Australia (Pty.) Ltd.**  
Riverstone, NSW, Australia  
(61) 02.9627.3322  
[sales@evapco.com.au](mailto:sales@evapco.com.au)

**EvapTech Asia Pacific Sdn. Bhd**  
*A wholly owned subsidiary of EvapTech, Inc.*  
Puchong, Selangor, Malaysia  
(60) 3.8070.7255  
[marketing-ap@evaptech.com](mailto:marketing-ap@evaptech.com)

### South America

**EVAPCO Brasil**  
*Equipamentos Industriais Ltda.*  
Indaiatuba, São Paulo, Brazil  
(55) 11.5681.2000  
[vendas@evapco.com.br](mailto: vendas@evapco.com.br)

**FanTR Technology Resources**  
Indaiatuba, São Paulo, Brazil  
(55) 11.4025.1670  
[fantr@fantr.com](mailto:fantr@fantr.com)

©2021 EVAPCO, Inc.