



Rigging & Assembly Instructions

ATC-DC
&
eco-ATWB-H

CONDENSER &
CLOSED CIRCUIT COOLER



Mr. GoodTower®



Method of Shipment

The ATC-DC and eco-ATWB-H induced draft coil products are shipped in three sections. These sections consist of the fan section, the coil section and the basin section. These sections have mating flanges and will join together in a waterproof joint when sealed and bolted together as described in the following instructions. Miscellaneous items, such as sealer, self-tapping screws and any other required materials, are packaged and placed inside the pan for shipment. For units consisting of multiple cells, drip channels and splash guards will ship loose in the basin for field installation. For 8.5' (2.4 m) wide units, the motors and drives are factory aligned and then shipped loose inside the basin section for mounting during installation. Refer to the "External Motor Installation" section in this bulletin. NOTE: All casing sections are factory inspected prior to shipment to verify proper fit for rigging. Please take extra care to handle and rig unit section per the instructions of this manual to avoid possible distortion and poor casing alignment. It is advisable to check each section upon receipt and during each lift to ensure that the factory alignment has not been altered. Should the field inspection indicate the section alignment ("square") has been altered, please contact the factory or your local EVAPCO representative for additional instructions to obtain proper section fit.

Storage

Do not place tarps or other coverings over the top of the units if the units are to be stored before installation. Excessive heat can build up if the units are covered causing possible damage to the PVC eliminators or PVC louvers. For extended storage beyond six months rotate the fan and fan motor shaft(s) monthly. Also, the fan shaft bearings should be purged and regreases prior to start-up.

International Building Code Provisions

The International Building Code (IBC) is a comprehensive set of regulations addressing the structural design and installation requirements for building systems – including HVAC and industrial refrigeration equipment. As of June 2008, all 50 states plus Washington D.C have adopted the International Building Code. The code provisions require that evaporative cooling equipment and all other components permanently installed on a structure must meet the same seismic design criteria as the building. The ATWB, eco-W and eco-WE Closed Circuit Coolers and ATC Evaporative Condensers are IBC 2012 compliant $\leq 1.0g$ or 2.87 kN/m^2 with standard construction and up to $\leq 5.12g$ or 6.94 kN/m with additional structural modifications.

All items attached to the Evapco ATWB, eco-W and eco-WE Closed Circuit Cooler or ATC Evaporative Condenser must be independently reviewed and isolated to meet applicable wind and seismic loads. This includes piping, ductwork, conduit, and electrical connections. These items must be flexibly attached to the Evapco unit so as not to transmit additional loads to the equipment as a result of seismic or wind forces.

Structural Steel Support

3', 4', 8.5', 10' and 12' (0.9 - 1.2 - 2.4 - 3 and 3.6 m) Wide Models

Two structural "I" beams running the length of the unit are required for supporting the unit. These beams should be located underneath the outer flanges of the unit. (See Figure 1.)

17', 20' and 24' (4.8 - 6 and 7.3 m) Wide Models

Three structural "I" beams running the length of the unit are required for supporting the unit. Locate two beams underneath the outer flanges of the unit, and locate one beam longitudinally along the center of the unit. (See Figure 2.)

All Models

Mounting holes, 3/4" (19 mm) in diameter, are located in the bottom flange for bolting to the structural steel (see certified print for exact bolt hole location). Bolt the bottom section to the steel support before rigging the top section.

Beams should be sized in accordance with accepted structural practices. Maximum deflection of the beam under the unit to be 1/360 of the unit length, not to exceed 1/2" (13 mm). Deflection may be calculated by using 55% of the operating weight as a uniform load on each beam (see certified print for operating weight).

The supporting "I" beams should be level before setting the unit. Do not level the unit by shimming between the bottom flange and the beams as this will not provide proper longitudinal support.

Note: Consult IBC 2012 for required steel support layout and structural design. and the beams as this will not provide proper longitudinal support.

Support beams and anchor bolts are to be furnished by others. Always refer to certified print for unit weights, dimensions and technical data.

Note: Consult IBC for required steel support layout and structural design.

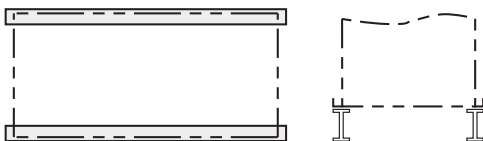

Figure 1 – Steel Support (3', 4', 8.5', 10' and 12' [0.9 - 1.2 - 2.4 - 3 and 3.6 m] wide models)



Figure 2 – Steel Support (17', 20' and 24' [4.8 - 6 and 7.3 m] wide models)

Rigging Basin Section

Lifting devices are located in the bottom corners of the basin (Figure 3). Additional lifting points can be found in the middle for basins with a length of 24' (7.3 m) and over (Figure 4). The hook of the crane must be a minimum dimension of "H" above the top of the section being lifted to prevent undue strain on the lifting devices. See Table 1 for the minimum "H" dimension. These lifting devices should not be used for extended lifts or where any hazard exists unless safety slings are employed under the section. (See "Extended Lifts" section for proper arrangement.) Bolt the basin section to the steel support before rigging the coil/fan section.

Basin Section Length	Min. "H" Dim.	Basin Section Length	Min. "H" Dim.
3-6 Feet (1.8 m)	8 Feet (2.4 m)	18 Feet (5.5 m)	19 Feet (5.7 m)
8.5 Feet (2.4 m)	10 Feet (3.0 m)	20 Feet (6.0 m)	21 Feet (6.3 m)
9 Feet (2.7 m)	10 Feet (3.0 m)	21 Feet (6.3 m)	22 Feet (6.6 m)
10.5 Feet (3.0 m)	11 Feet (3.3 m)	24 Feet (7.3 m)	15 Feet (4.6 m)
12 Feet (3.6 m)	15 Feet (4.6 m)	28 Feet (8.4 m)	16 Feet (4.8 m)
14 Feet (4.2 m)	17 Feet (5.1 m)	36 Feet (10.8 m)	19 Feet (5.7 m)
		40 Feet (12 m)	21 Feet (6.3 m)

Table 1 – Minimum "H" Dimension for Basin Sections

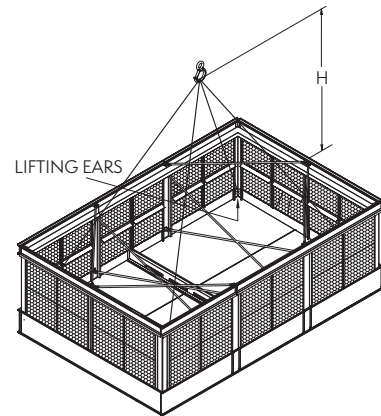

Figure 3 – Basin Section up to 21' (6.3 m) long

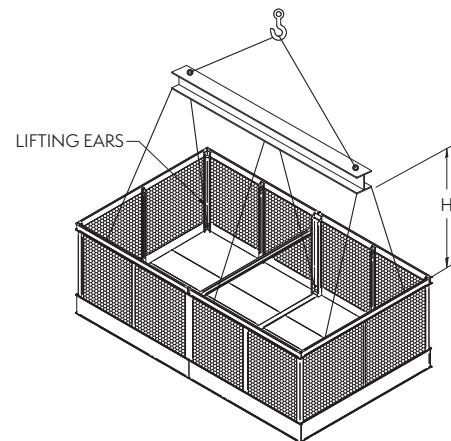

Figure 4 – Basin Section 24' to 40' (7.3 to 12 m) long

Joining Multi-Cell Units

Basin Sections - 10' & 12' (2.4 - 2.6 and 3.6 m) Wide Models; 24' to 40' (7.3 to 12 m) Long)

The bottom sections are shipped separately and are furnished with a connecting equalizer flume between them. In addition to the equalizer flumes, these units are provided with drip channels and splash guards to keep water from exiting between the cells.

The equalizer flume is factory installed on one section for field connection to the other. It is important to connect the equalizer flume to balance the water level in the pans for proper pump suction operation. The following procedures are to be performed in sequence.

1. Install the basin section with the factory installed flume on it as described earlier.
2. Clean the flanges on the equalizer flume on the end to be field connected. Apply a layer of sealer tape on the flange centered between the hole centers and the outside edge. Remove paper backing strip from the sealer tape. (See Figure 5.)
3. Clean the mating surface of the equalizer opening of any dirt, grease or moisture.

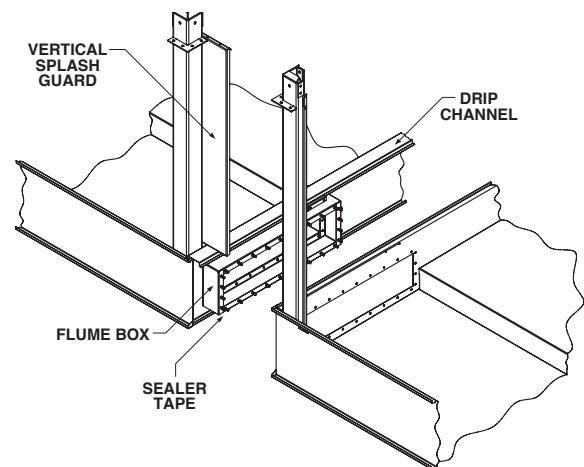

Figure 5 – Equalizer Flume Connection, 12' (3.6 m) Wide Models

Joining Multi-Cell Units

Basin Sections - 10' & 12' (2.4 - 2.6 and 3.6 m) Wide Models 24' to 40' (7.3 to 12 m)

4. Rig the second basin section adjacent to the equalizer flume on the steel support as shown in Figure 6.
5. Align the bolt holes in the equalizer flume and equalizer opening with drift pins (drift pins provided by others) while drawing the second basin section against the flanged connection.
6. Install 3/8" (10 mm) bolts, nuts and washers in every hole around the equalizer opening and tighten. Cut off excess sealer tape.
7. Bolt the second basin section to the steel support.
8. Place the drip channel over the adjoining pan section flanges. Secure by installing 5/16" (8 mm) self-tapping screws through the retaining clips into the end panels. For stainless steel construction, secure by installing 1/4" (6 mm) stainless steel bolts through the retaining clips into brass rivnuts secured in the end panel. (See Figure 7.)
9. Place the vertical splash guard in the bend of the vertical supports. Attach the vertical splash guard using 5/16" (8 mm) tappers. For stainless steel construction, attach the vertical splash guard using 5/16" (8 mm) stainless steel nuts and bolts. (See Figure 5.)

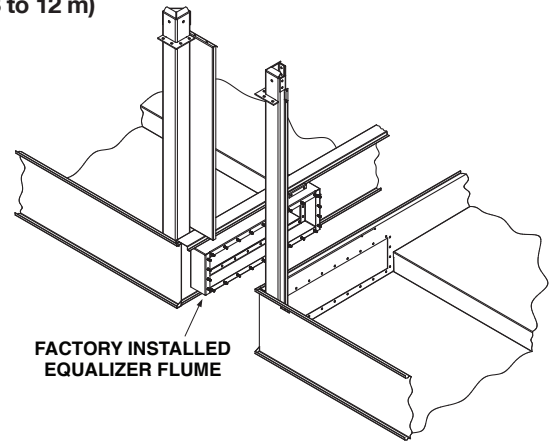

Figure 6 – Equalizer Flume Rigging Detail, 12' (3.6 m) Wide Models

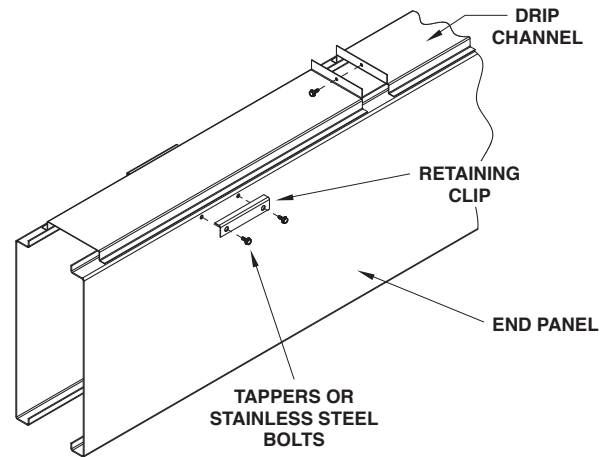

Figure 7 – Drip Channel Installation

Joining Multi-Cell Units

Basin Sections - 17' 20' & 24' (4.9 - 5.3 and 7.3 m) Wide Models, 12' to 40' (3.6 to 12 m) Long

On 17' 20' and 24' (4.9 - 5.3 and 7.3 m) wide models the equalizer flume is located on the sides of adjoining basin sections. This flume is shipped loose and must be installed to both basin sections. In addition to the equalizer flume, these units are provided with drip channels and splash guards to keep water from exiting between the cells. The following procedure should be performed in order to assure proper assembly.

1. Install one basin section of the unit on structural steel and secure as described earlier.
2. Mating flanges which will make contact with others should be cleaned to remove dirt, grease and moisture. Apply a layer of sealer tape on one side panel centered over the flume box holes as shown in Figure 8. Remove paper backing strip from the sealer tape.
3. The side of the flume box which has studs installed in it should now be connected to the side panel. The studs are pushed through the sealer tape and holes of the side panel and are secured by washers, lock washers and nuts.

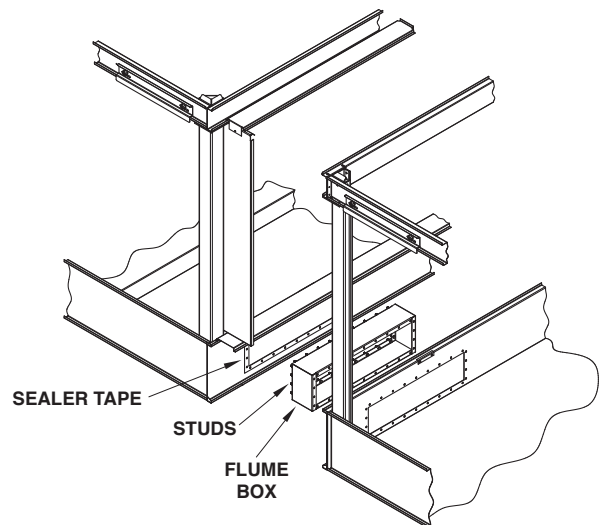

Figure 8 – Equalizer Flume Assembly, 17' & 24' (4.9 - 5.3 & 7.3 m) Wide Models

Joining Multi-Cell Units

Basin Sections - 17' and 24' (4.9 and 7.3 m) Wide Models, 12' to 40' (3,6 to 12 m) Long

4. Clean the mating flanges on the equalizer flume on the end to be field connected. Apply a layer of sealer tape on the flange, centered between the hole centers and the outside edge. Remove paper backing strip from the sealer tape.
5. Clean the mating surface of the side panel of any dirt, grease or moisture. Rig the second basin section adjacent to the equalizer flume on the steel support.
6. Align the bolt holes in the equalizer flume and equalizer opening with drift pins while drawing the second basin section against the first as shown in Figure 8.
7. Install 3/8" (10 mm) bolts, nuts and washers in every hole around the equalizer opening and tighten. Cut off excess sealer tape to prevent strainer blockage.
8. Bolt the second basin section to the steel support.
9. Place the drip channel over the adjoining pan section flanges. Secure by installing 5/16" (8 mm) self-tapping screws through the retaining clips into the side panel. For stainless steel construction, secure by installing 1/4" (6 mm) stainless steel bolts through the retaining clips into brass rivnuts secured in the side panel. (See figures 8 & 9.)
10. Fasten the drip channel sections together, end to end, by driving a self-tapping 5/16" (8 mm) screw through the section end with the larger hole into the mating end with the smaller hole. Stainless steel units will use 5/16" (8 mm) stainless steel nuts, bolts, and washers. (See Figure 9.)
11. Place the vertical splash guard in the bend of the vertical supports. Attach the vertical splash guard using 5/16" tappers. For stainless steel construction, attach the vertical splash guard using 5/16" (8 mm) stainless steel nuts and bolts. (See Figure 10.)

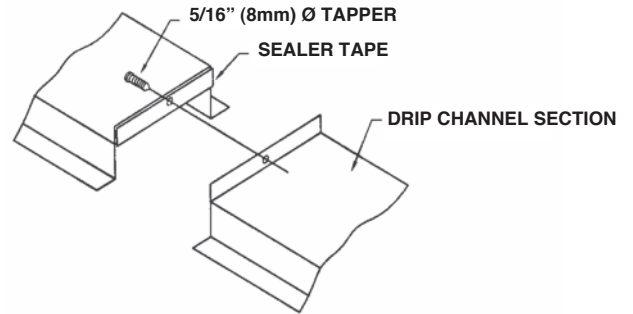

Figure 9 – Drip Channel Assembly

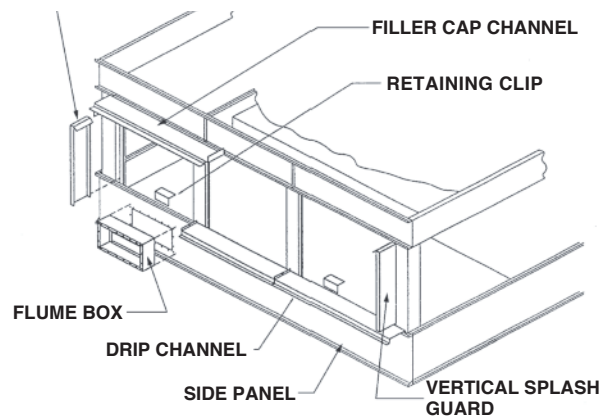

Figure 10 – Drip Channel and Splash Guards, 17' & 24' (4.9 - 5.3 & 7.3 m) Wide Models

Applying Sealer Tape

Once the bottom section has been set on the supporting steel and bolted in place, the top flanges should be wiped down to remove any dirt or moisture. Sealer tape should be placed over the mounting hole centerline on the side flanges. Apply two strips of sealer tape, one partially overlapping the other, on the end flanges.

The sealer tape should overlap on the corners as shown in Figure 11. Do not splice the sealer tape along the end flanges and preferably not on the side flanges if it can be avoided. Units that are 24' to 40' (7.3 to 12 m) in length have two or more coil/fan sections. In these cases, sealer must be applied to all internal flanges. Cut off excess sealer tape once the top section has been properly set into place and the rig is complete.

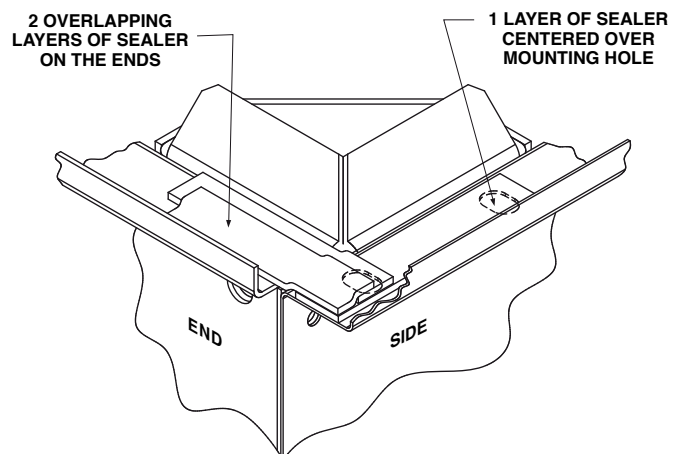

Figure 11 – Proper Sealer Tape Application

Coil/Fan Section

Coil Section

Four lifting ears are provided in the lower corners of most coil/fan sections for lifting into final position. 18', 20' and 21' (5.5, 6 and 6.4 m) long sections will have two additional lifting ears in the middle of the section. Use all lifting ears. A spreader beam must be used for lifting the top section(s) as shown in Figures 12 and 13. The hook of the crane must be a minimum dimension "H" above the top section being lifted to prevent undue strain on the lifting ears. See Table 2 for the minimum "H" dimension. These lifting devices should not be used for extended lifts or where any hazard exists unless safety slings are employed under the section. (See "Extended Lifts" for proper arrangement.)

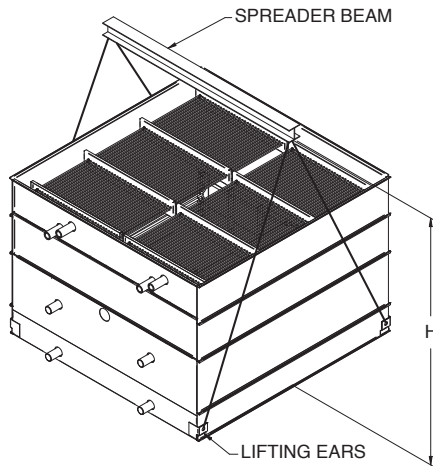

Figure 12 – Four Point Lift

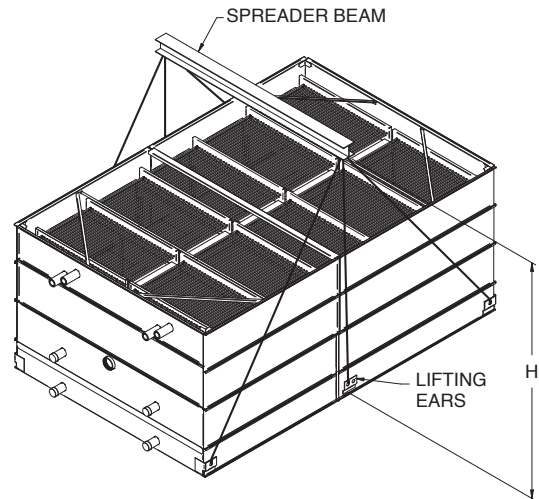

Figure 13 – Four Point Lift

Fan Section

Four lifting ears are provided in the lower corners of most coil/fan sections for lifting into final position. Some fan sections will have a lifting ear located on the motor support in addition to two U-Bolts located on the top of the fan deck (See Figure 15.) Use all lifting ears. A spreader beam must be used for lifting the top section(s) as shown in Figures 14. The hook of the crane must be a minimum dimension "H" above the top section being lifted to prevent undue strain on the lifting ears. See Table 2 for the minimum "H" dimension. These lifting devices should not be used for extended lifts or where any hazard exists unless safety slings are employed under the section. (See "Extended Lifts" for proper arrangement.)

Note: For 8.5' (2,4 m) wide models, mount the external motor prior to rigging as detailed in the "External Motor Installation" section.

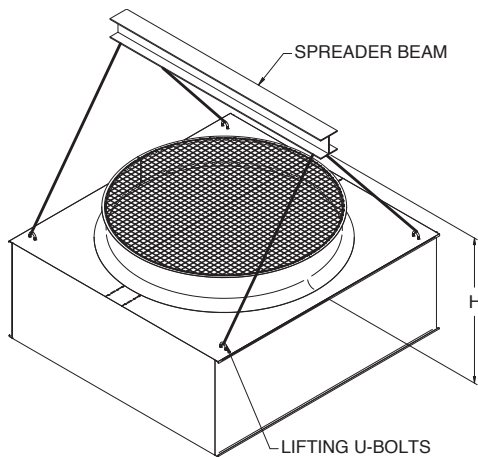

Figure 14 – Four Point Lift

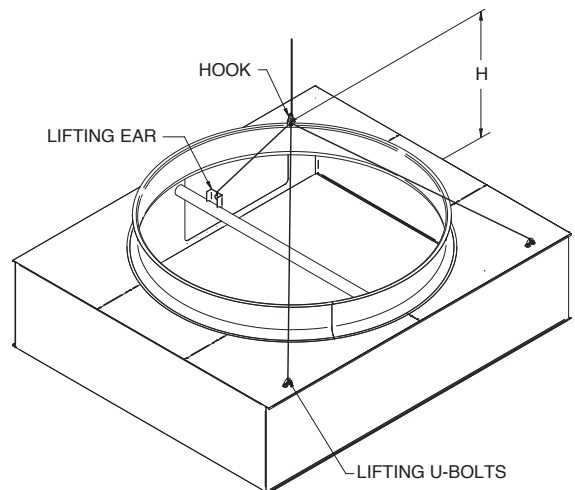

Figure 15 – Three Point Lift

Fan/Coil Section	Min. "H" Dimension
3-6 Feet (1.8 m)	8 Feet (2.4 m)
8.5 and 9 Feet (2.6 and 2.7 m)	9 Feet (2.7 m)
10.5 Feet (3.0 m)	11 Feet (3.3 m)
12 Feet (3.6 m)	12 Feet (3.6 m)
14 Feet (4.2 m)	14 Feet (4.2 m)
18 Feet (5.5 m)	17 Feet (4.9 m)
20 Feet (6 m)	18 Feet (5.5 m)
21 Feet (6.3 m)	19 Feet (5.7 m)

Table 2 – Minimum "H" Dimension for Coil/Fan Sections

Extended Lifts

Important: The lifting devices and "U" bolts should be used for final positioning only and for lifting where no danger exists. If they are used for extended lifts, safety slings should be provided under the sections.

The preferred method for extended lifts is to use slings under the unit. (See Figure 16.) Spreader bars should always be used between the cables at the top of the section to prevent damage to the upper flanges or fan cylinders.

Safety slings and skids should be removed before final positioning of the unit. Refer to Tables 1 and 2 for minimum "H" dimensions.

Move basin extended lift and casing extended lift behind each standard section.

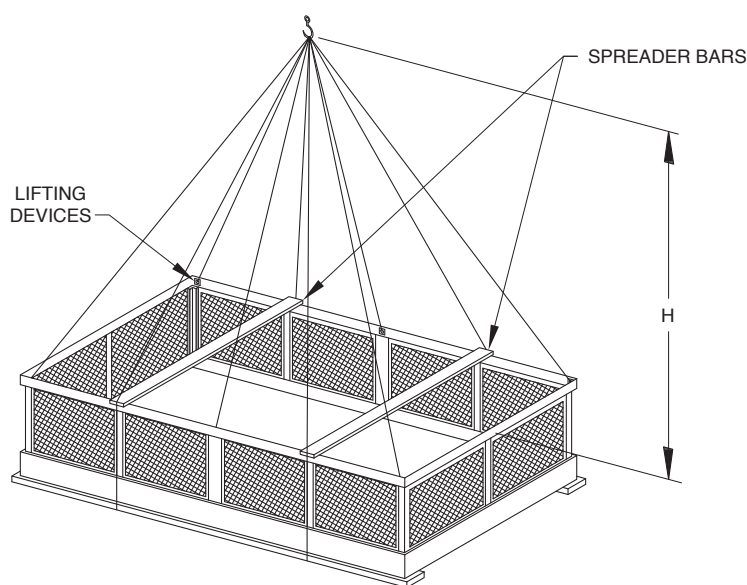

Figure 16 – Extended Lifts, Basin Section

Assembly of the Coil Section to the Basin

Section 3', 4', 8.5', 10' and 12' (1.2 - 2.4 - 2.6 and 3.6 m) Wide Models

Before assembling the coil section to the basin section, remove any loose parts shipped in the pan. Four lifting ears are provided in the corners of most coil sections for lifting into final position. 18', 20' and 21' (5.5, 6 and 6.3 m) long sections will have two additional lifting ears in the middle of the section. Use all lifting ears. When lifting the coil sections, use the lifting ears at the bottom of the coil section. The hook of the crane must be a minimum dimension "H" above the top section being lifted to prevent undue strain on the lifting ears. See Table 2 for the minimum "H" dimension. These lifting devices should not be used for extended lifts or where any hazard exists unless safety slings are employed under the section. (See Extended Lifts' for proper arrangement.)

Before assembling the fan section to the coil section, wipe the flanges on the bottom of the fan section and apply sealer tape. Check to see that the access doors are in the correct position relative to the coil section (see certified print). Units are also provided with match markings on each section (i.e. A1 of the coil section should match up with the A1 of the basin section). Place nuts and bolts in all four corner bolt holes. Then continue to install the rest of the nuts and bolts working from the corners towards the center. Nuts and bolts are required on the end flanges. Use drift pins to assist with alignment.

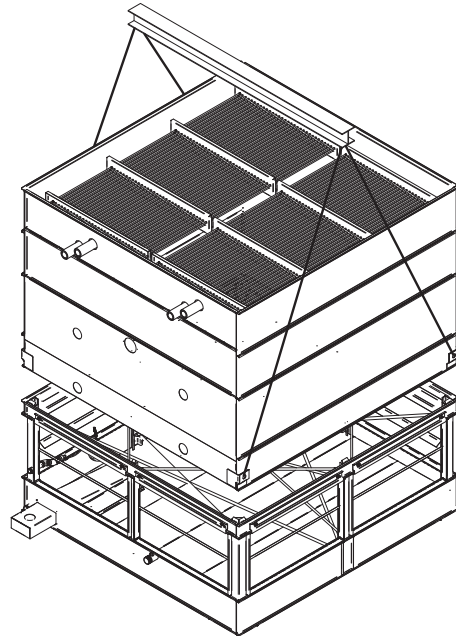

Figure 17 – Mating Upper Section to Basin Section

Note: 3/8" (10 mm) stainless steel nuts, bolts and washers are used for stainless steel construction. 3', 4' (1.2 m) wide units use 5/16" (8 mm) stainless steel nuts, bolts and washers for stainless steel construction.

Assembly of the Coil Section to the Basin

Section 3', 4', 8.5', 10' and 12' (1.2 - 2.4 - 2.6 and 3.6 m) Wide Models

Four lifting U-Bolts are provided in the top corners of most fan sections for lifting into final position. 18', 20' and 21' (5.5, 6 and 6.3 m) long sections will have two additional U-Bolts in the middle of the fan section. Use all U-Bolts. The hook of the crane must be a minimum dimension "H" above the top section being lifted to prevent undue strain on the lifting ears. See Table 2 for the minimum "H" dimension. These lifting devices should not be used for extended lifts or where any hazard exists unless safety slings are employed under the section (See Extended Lifts' for proper arrangement).

Before assembling the fan section to the coil section, wipe the flanges on the bottom of the fan section and apply sealer tape. Check to see that the motor access doors are in the correct position relative to the coil section (see certified print). Units are also provided with match markings on each section (i.e. A1 of the coil section should match up with the A1 of the fan section). Place nuts and bolts in all four corner bolt holes. Then continue to install the rest of the nuts and bolts working from the corners towards the center. Nuts and bolts are required on the end flanges. Use drift pins to assist with alignment.

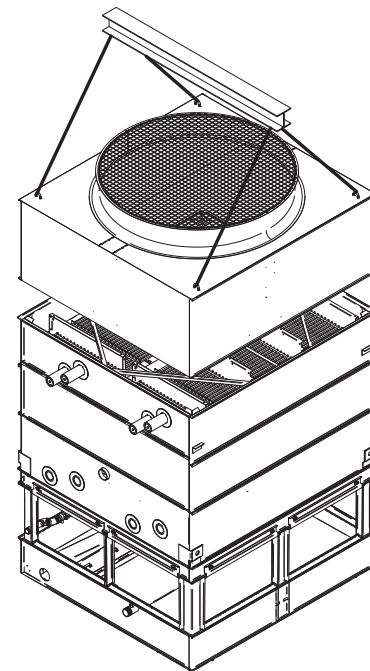

Figure 18 – Mating Fan Section to Coil/Basin

Note: 3/8" (10 mm) stainless steel nuts, bolts and washers are used for stainless steel construction. 3', 4' (1.2 m) wide units use 5/16" (8 mm) stainless steel nuts, bolts and washers for stainless steel construction.

Assembly of the Coil Section to the Basin

Section 17', 20' and 24' and 12' (4.8 - 6 and 7.3 m) Wide Models - Fan Section Will Need To Be Mounted to the Coil Section First

Four lifting U-Bolts are provided in the top corners of most fan sections for lifting into final position. 18', 20' and 21' (5.5, 6 and 6.3 m) long sections will have two additional U-Bolts in the middle of the fan section. Use all U-Bolts. The hook of the crane must be a minimum dimension "H" above the top section being lifted to prevent undue strain on the lifting ears. See Table 2 for the minimum "H" dimension. These lifting devices should not be used for extended lifts or where any hazard exists unless safety slings are employed under the section. (See Extended Lifts' for proper arrangement.) Note: for 8.5' (2.4 m) wide cells (17' [4.8 m] wide models), mount the external motor prior to rigging as detailed in the "External Motor Installation" section.

Before assembling the fan section to the coil section, wipe the flanges on the bottom of the fan section and apply sealer tape. Check to see that the motor access doors are in the correct position relative to the coil section (see certified print). Units are also provided with match markings on each section (i.e. A1 of the coil section should match up with the A1 of the fan section). Place nuts and bolts in all four corner bolt holes. Then continue to install the rest of the nuts and bolts working from the corners towards the center. Nuts and bolts are required on the end flanges. Drift pins are provided in rigging box to assist with alignment.

Note: 3/8" (10 mm) stainless steel nuts, bolts and washers are used for stainless steel construction. 3', 4' (1.2 m) wide units use 5/16" (8 mm) stainless steel nuts, bolts and washers for stainless steel construction.

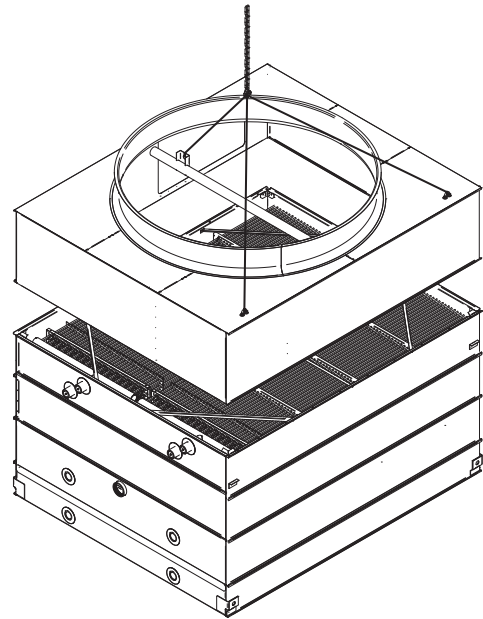

Figure 19 – Mating Fan Section to Coil Section

Assembly of the Coil Section to the Basin

Section 17', 20' and 24' and 12' (4.8 - 6 and 7.3 m) Wide Models - Fan Section Will Need To Be Mounted to the Coil Section First

Before assembling the coil section to the basin section, remove any loose parts shipped in the pan. Four lifting ears are provided in the corners of most coil sections for lifting into final position. 18', 20' and 21' (5.5, 6 and 6.3 m) long sections will have two additional lifting ears in the middle of the section. Use all lifting ears. When lifting assembled fan/coil sections, use the lifting ears at the bottom of the coil section and not the U-Bolts of the fan section. The hook of the crane must be a minimum dimension "H" above the top section being lifted to prevent undue strain on the lifting ears. See Table 2 for the minimum "H" dimension. These lifting devices should not be used for extended lifts or where any hazard exists unless safety slings are employed under the section. (See Extended Lifts' for proper arrangement.)

Before assembling the fan/Coil section to the basin section, wipe the flanges on the bottom of the coil section and apply sealer tape to the basin section. Check to see that the access doors are in the correct position relative to the basin section (see certified print). Units are also provided with match markings on each section (i.e. A1 of the coil section should match up with the A1 of the fan section). Place nuts and bolts in all four corner bolt holes. Then continue to install the rest of the nuts and bolts working from the corners towards the center. Nuts and bolts are required on the end flanges. Drift pins are provided in rigging box to assist with alignment.

Note: 3/8" (10 mm) stainless steel nuts, bolts and washers are used for stainless steel construction. 3', 4' (1.2 m) wide units use 5/16" (8 mm) stainless steel nuts, bolts and washers for stainless steel construction.

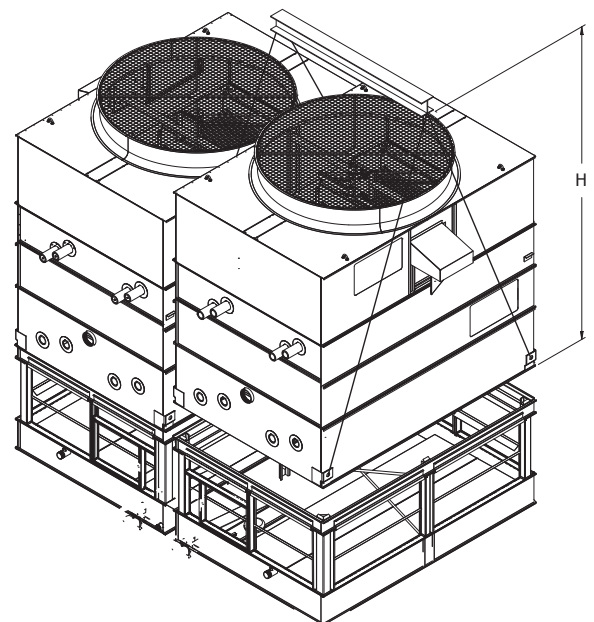

Figure 20 – Mating Fan/Coil Section to Basin Section

Mounting Fan Screens

10' & 12' (3 & 3.6 m) Wide by 12' or 24' (3.6 or 7.3 m) Long Models
 20' & 24' (6 & 7.3 m) Wide by 12' or 24' (3.6 or 7.3 m) Long Models

WARNING: DO NOT WALK ON THE FAN SCREENS AT ANY TIME!

1. Place both halves of the fan screen on top of the discharge cylinder. Each half will be tagged to match markings on the cylinder. Align the eyelets of the fan screen with the holes that can be found on the perimeter of the discharge cylinder.
2. At each hole, attach the fan screen to the discharge cylinder as shown in Figure 21.
3. Join the two screen halves with wire clips (Figure 22). There should be 4 wire clips on each side of the fan screen. Space the wire clips evenly across the radius of the fan screen as shown in Figure 23.

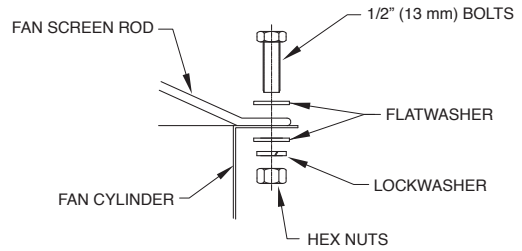

Figure 21 – Attaching Fan Screen to Cylinder

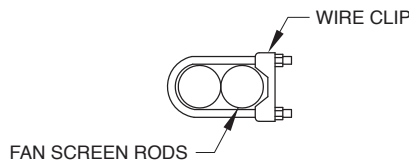

Figure 22 – Wire Clip Arrangement

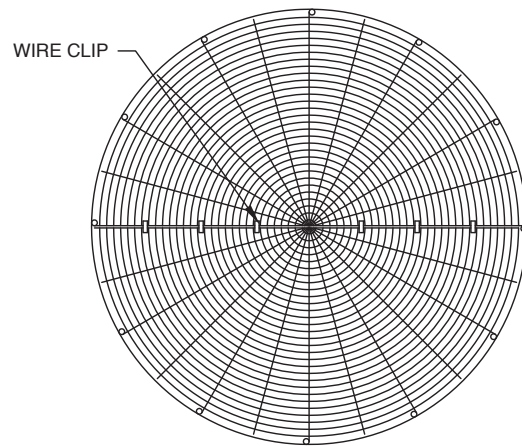

Figure 23 – Wire Clip Spacing

Mounting Fan Screens

10' & 12' (3 & 3.6 m) Wide by 14' (4.2 m) through 20' (6 m) Long Models
 10' & 12' (3 & 3.6 m) Wide by 28' (8.5 m) through 40' (12 m) Long Models
 20' & 24' (6 & 7.3 m) Wide by 14' (4.2 m) through 20' (6 m) Long Models
 20' & 24' (6 & 7.3 m) Wide by 28' (8.5 m) through 40' (12 m) Long Models

On these models, the fan screen is supported from underneath by an "X" shaped support frame.

1. Set the support frame across the top of the discharge cylinder (See Figure 24).
2. Place both halves of the fan screen on top of the support frame. Each half will be tagged to match markings on the cylinder. Align the eyelets of the fan screen with the holes on the cylinder perimeter.
3. Join the two screen halves with wire clips (See Figure 22). There should be four clips on either side of the fan screen. Space them evenly as shown in Figure 23.
4. At each hole, attach the fan screen to the discharge cylinder as shown in Figure 21. At the four points where the support frame meets the cylinder, bolt the support frame to the cylinder together with the fan screen.

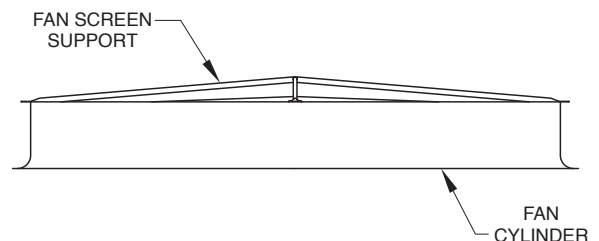

Figure 24 – Support Frame Installation

Assembly of Sloped Ladders

When sloped ladders are supplied with a unit, they are shipped in the basin of the unit. One sloped ladder will be provided for each cell. Assembly is identical for each cell.

See Figures 26 & 27 for end and side view ladder arrangement.

Sloped ladders are attached at a minimum of three points. Taller units will be attached at four points. At each point of attachment, the ladder will be fitted with a ladder bracket assembly. The ladder bracket assembly looks like a metal box and is shown in detail (component #4) in Figure 25 below. The upper two assembly brackets will be rigidly mounted to the ladder and are not adjustable. These two brackets define the slope of the ladder. The lower brackets are adjustable.

NOTE: Upper Section of Unit Must Be Properly Oriented with Respect to Lower Section. All Mounting Brackets Must be on Same Side of Unit. Refer to Certified Print For Proper Orientation.

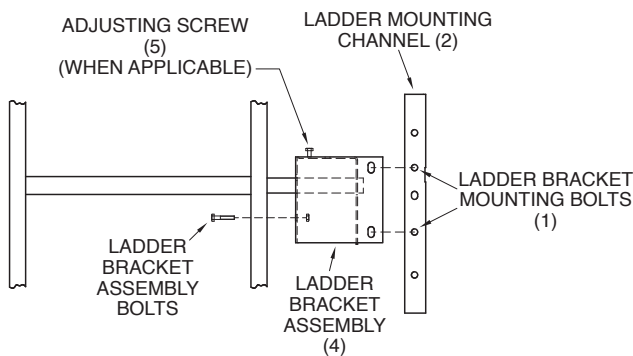

Figure 25 – Detail of Ladder, Ladder Bracket Assembly and Mounting Channel

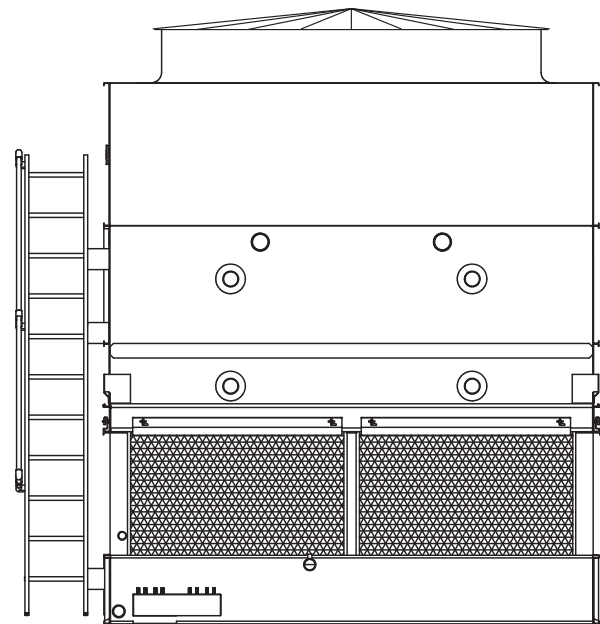

Figure 26 – End View of Ladder Assembly

To install the ladder assembly, follow the steps outlined below which refer to Figure 25

1. Remove the ladder bracket mounting bolts (1) from the ladder mounting channels (2) on pan and casing sections.
2. Loosen, but do not remove, the ladder bracket and assembly bolts (3).
3. Slide the ladder bracket assembly (4) over the ladder mounting channels (2) located on the pan and casing sections. Do not remove the ladder bracket assembly (4) from the ladder.
4. Align the bolt holes and reinstall the ladder bracket mounting bolts (1) through the ladder bracket assembly and the ladder mounting channels (2).
5. Tighten all bolts.
6. Tighten the adjusting screw (5) in the adjustable mounting bracket where applicable.

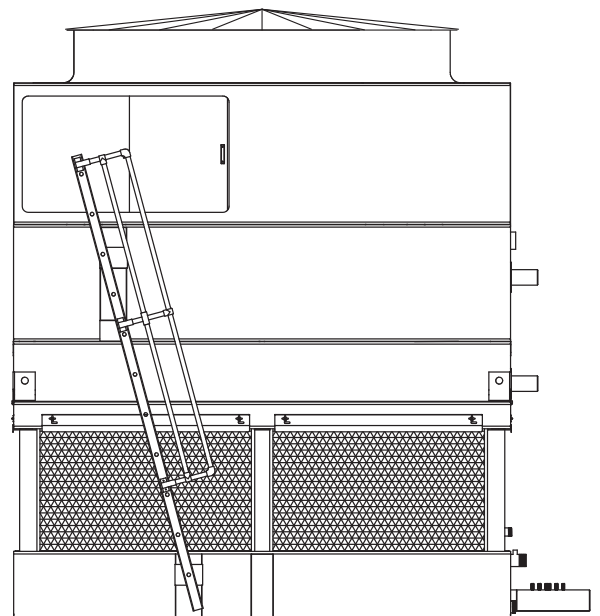
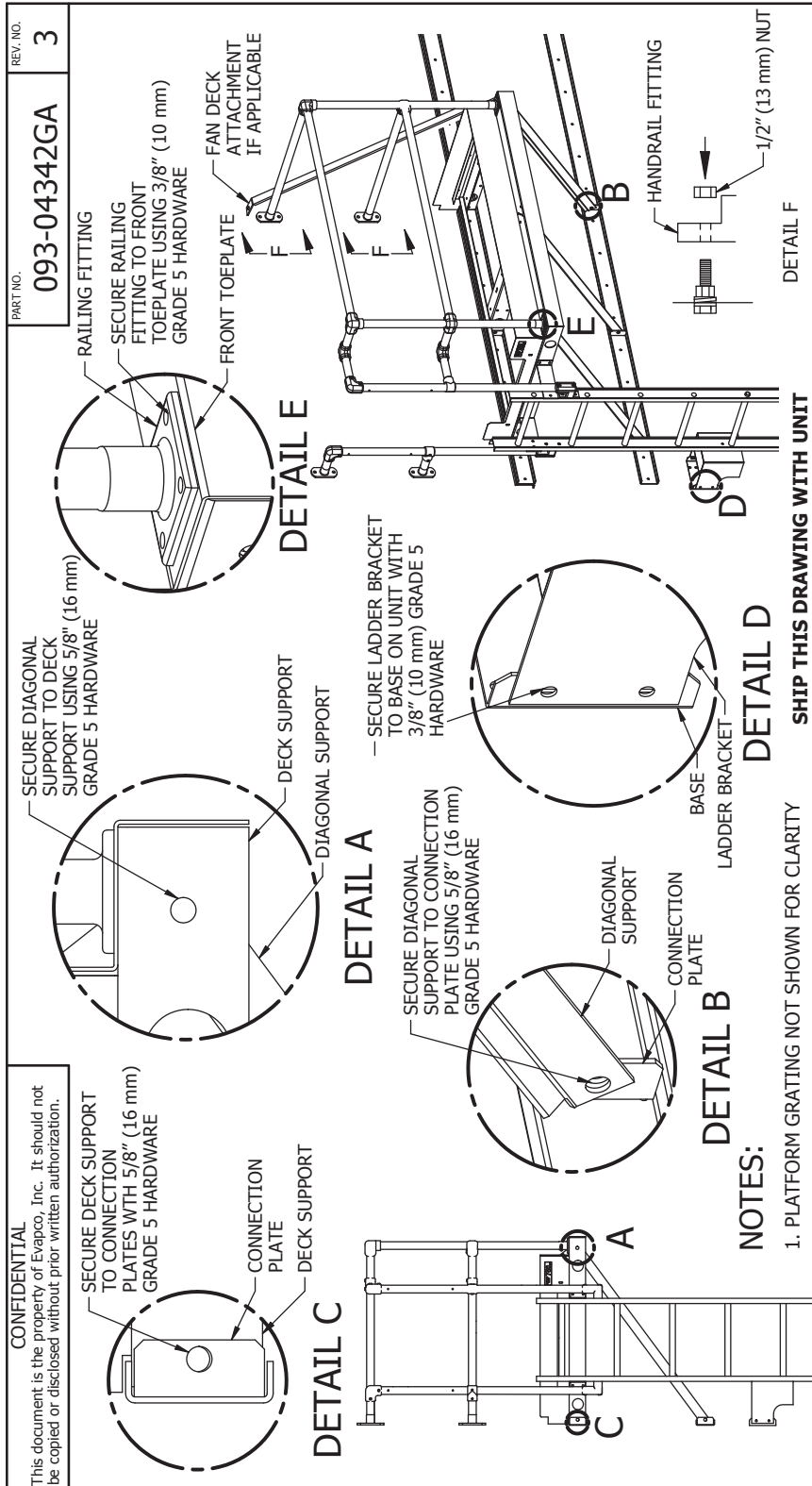

Figure 27 – Side View of Ladder Assembly

Field Assembly of Working Platform and Ladder

The working platform/ladder assemblies are shipped in the basin of the unit. In some cases they are shipped separately due to basin accessories that interfere with storage. The platform is partially assembled prior to shipment for minimal field assembly.

The platform and ladder assembly should be attached after the unit is fully rigged following the instructions below.



Optional Motor and Gear Box Davit
ATC-DC and eco-ATWB-H 8.5', 10' and 12' (2.4, 3 and 3.6 m)

A removable, dual point motor davit is provided on 8.5', 10' and 12' (2.4, 3 and 3.6 m) wide models for both the Powerband Belt Drive System and the optional gear drive system (Figure 28.)

This accessory is available to aid in the removal of fan motors and gear boxes. The assembly consists of a davit and a mounting base/channel that is attached to the side of the unit next to the access door. Both of these items will ship loose in the unit's basin. Use the following procedure to install the mounting channel.

1. Place the mounting channel on the factory-installed mounting brackets near the access door.
2. At each hole, attached the mounting channel to the bracket using 3/8" (10 mm) hardware as shown in Figure 29.

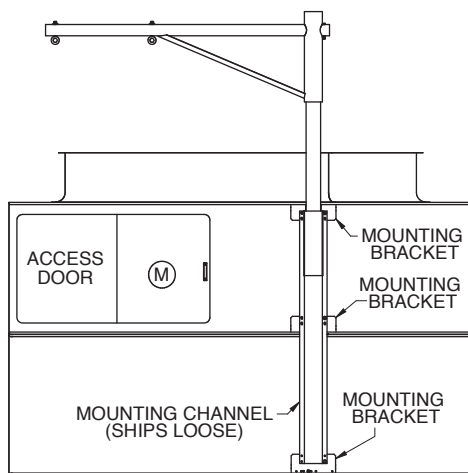

Figure 28

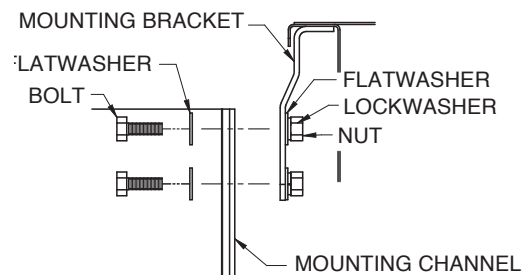

Figure 29

Optional Discharge Hood Damper

Section Assembly
ATC-DC and eco-ATWB-H Models

Once the upper section (casing/fan section) has been secured to the bottom section, inspect the top of the upper section to ensure removal of any shipping blocks or other obstructions. Lower the discharge hood damper section onto the top of the upper section while aligning the holes located in each corner.

Place self-tapping bolts in all four corner bolt holes. Continue to install the rest of the self-tapping bolts working from the corners toward the center. A self-tapper must be installed in every hole on the side flanges although none are required on the end flanges.

NOTE: Do not use U-bolts to lift the discharge hood damper section when attached to another part of the equipment. Always lift the hood.

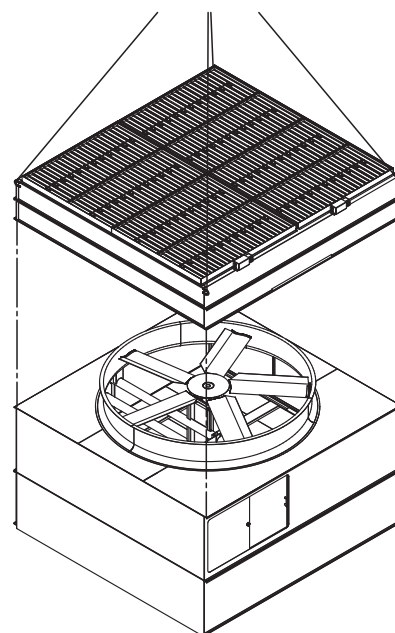

Figure 30 – Mating Discharge Hood Damper Section to Coil/Fan Section

External Motor Installation

3', 4' & 8.5' (1.2 & 2.4 m) Wide Models (Note: 3' & 4' [1.2 m] motors ship mounted)

1. Study Figure 31 before installing the motor base on the unit.
2. Insert the lifting device into "U" bolt **A** on motor base **B**.
3. Lift the motor base and insert the pivot pin down into hole **E** and pivot pin **F** into hole **D**.
4. Install washer and nut (do not overtighten) on pivot pins. Install jam nut on pivot pin **C**.
5. Insert "J" bolts **G** into holes **H**. Install flat washers and cotter pins. Place nuts and washers on threaded portion of "J" bolts. These will be behind the motor base installed in the next step.
6. Insert "J" bolts into holes **J** in the motor base. Install flat washers, lock washer and nuts. Remove lifting device from the "U" bolt on the motor base. Position motor base toward casing of unit for belt installation.
7. Install Powerband belt **K** (Figure 32) around fan sheave and motor sheave. Tighten belt by adjusting nuts on "J" bolts. Do not over tighten the belts. The center of the belt should deflect approximately 3/4" (19 mm) with moderate hand pressure.
8. Measure to see that the top and bottom of the motor base are the same distance out from the casing of the unit. This should ensure that the sheaves are properly aligned as they have been pre-set at the factory.
9. As a final check, lay a straight edge from sheave to sheave. There should be four point contact (See Figure 33). Adjust the position of the motor sheave as necessary.
10. To install Motor Guard **L**, match up hinges and install hinge pins **M** (See Figure 32).
11. Close Motor Guard and install two (2) wing bolts **N**.

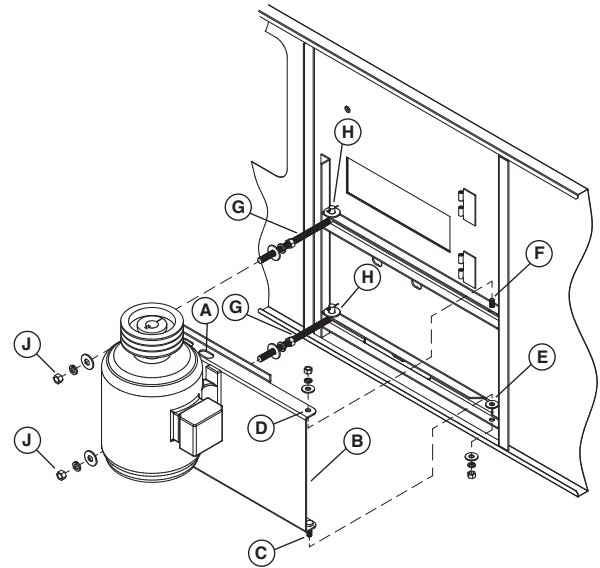

Figure 31 – External Motor Installation

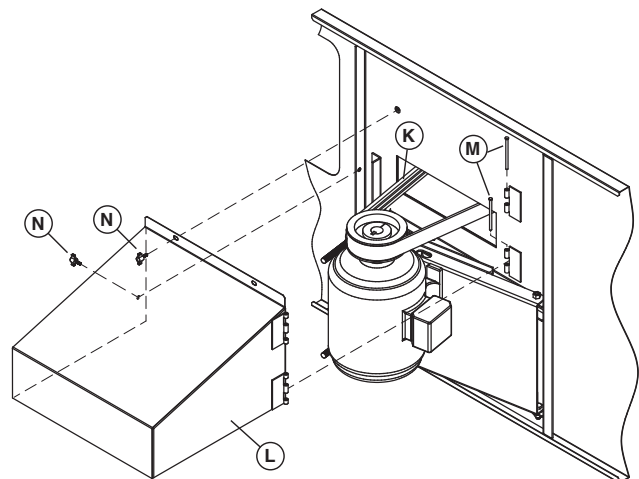

Figure 32 – Motor Guard and Powerband Belt Installation

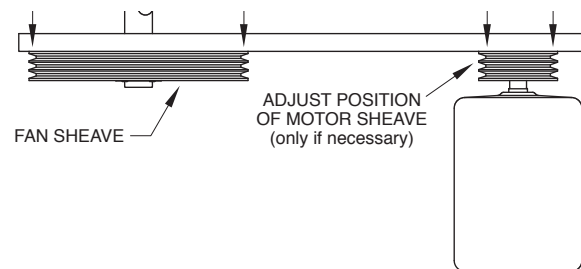

Figure 33 – Sheave Alignment Check

Start-up Details

Debris

Clean all debris from the basin prior to start-up. Close and secure all access doors.

Pump Discharge Line

Connect the riser pipe from the pump discharge on the basin section to the riser pipe on the coil/fan section using the flexible connection and hose clamps provided.

Bleed-off Line

A bleed-off line and valve are installed on the unit when shipped with a pump. On units shipped without a pump (remote sump applications) make sure a bleed-off line and valve are properly sized and installed on the discharge side of the pump and connected to a convenient drain. In either case, the bleed-off valve should be fully open.

Strainer

Check the strainers, if applicable, in the basin section to make certain they are in the proper location over the pump suction, along side of the anti-vortex hood. (See Figure 34.)

Screens

Protective fan screens are provided across the top of the fan cylinders of all models. Check and tighten all bolts.

Float Valve Adjustment

The float valve is pre-set at the factory; however, adjustment should be checked after rigging. The float valve should be adjusted so that the centerline of the float is at the measurement shown in Table 3 or 4 from the basin bottom. Raise or lower the float by using the wing nuts on the vertical threaded rod only. Do not adjust the horizontal rod.

Starting Sequence

Before starting the unit, check that all access openings, safety screens and covers are in place. Start the unit as outlined below:

1. Fill the pan to the overflow level.
2. Bump start and check the spray water pump(s) for proper rotation. Directional arrows are found on the pump impeller
3. Bump start and check the fan(s) for proper rotation. Directional arrows are placed on the side of the fan cylinder.

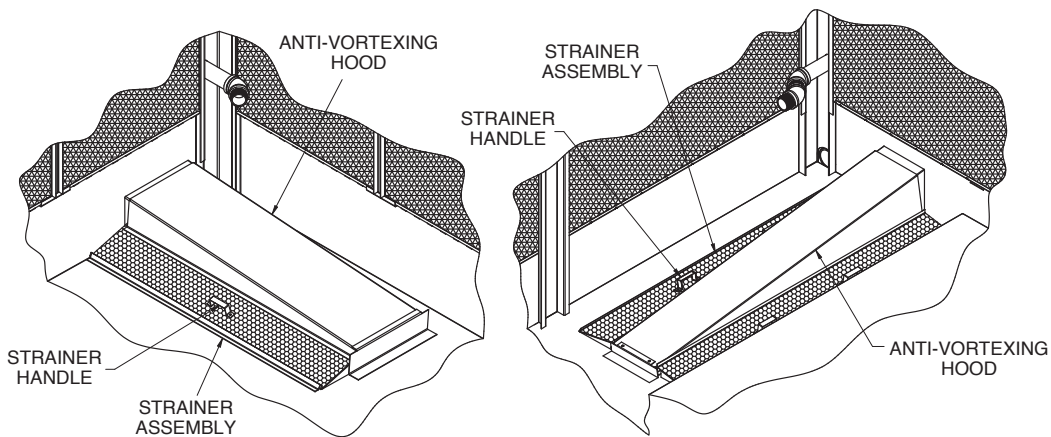

Figure 34 – Strainer Location

Unit Length	Level
to 9' (2.7 m)	8" (220 mm)
12' (3.6 m)	10" (300 mm)

Table 3 – Float Valve Adjustment 4' (1.2 m) Wide Models

Unit Length	Level
All Models	11" (340 mm)

Table 4 – Float Valve Adjustment 8.5' through 24' (2.4 through 7.3 m) Wide Models

Maintenance

Once the installation is complete and the unit is turned on, it is important that it be properly maintained. Maintenance is not difficult or time-consuming but must be done regularly to assure full performance of the unit. Refer to the operation maintenance instructions enclosed with the unit for proper maintenance procedures.

Freeze Protection

Proper freeze protection must be provided if the unit is located in a cold climate. Refer to the operation maintenance instructions as well as product bulletins for further information.

Rigging Hardware Parts List

The following table lists those parts which are shipped together with the unit(s) for field assembly and/or spare parts.

ATC-B Model ATWB Model	Box Size	Flume Hard	Rigging Joint Hardware	Sealer Tape	ZM® Nozzles
50B to 80B 24-3G to 24-5G	4x6	0	35	2	1
90B to 120B 36-3F to 36-5F	4x9	0	45	2	1
135B to 165B 48-3F to 48-5G	4x12	0	55	3	1
187B to 247B 64-3H to 64-6J	8.5x7.5	0	16	4	2
218B to 305B 77-3I to 77-6K	8.5x9	0	14	4	2
246B to 369B 89-3I to 89-6L	8.5x10.5	0	16	4	2
358B to 409B 102-3J to 102-6L	8.5x12	0	18	5	2
385B to 473B 119-3J to 119-6M	8.5x14	0	22	5	2
486B to 630B 153-3I to 153-6K	8.5x18	0	26	5	2
508B to 755B 179-3I to 179-6L	8.5x21	0	30	6	2
643B to 809B	8.5x24	22	36	10	2
800B to 950B	8.5x28	22	44	10	2
639B to 805B 204-3J to 204-6L	17x12	22	36	10	2
780B to 926B 238-3J to 238-6M	17x14	22	44	10	2
428B to 583B 144-3K to 144-6N	12x12	0	18	5	2
545B to 647B 168-3L to 168-6N	12x14	0	22	6	2
	3x3	0	22	1	1
	4x4	0	25	2	1

ATC-B Model ATWB Model	Box Size	Flume Hard	Rigging Joint Hardware	Sealer Tape	ZM® Nozzles
642B to 892B 216-3L to 216-6O	12x18	0	26	6	3
791B to 967B 240-3M to 240-6P	12x20	0	30	7	3
858B to 1167B 286-3K to 286-6N	12x24	26	36	10	3
1164B to 1294B 334-3L to 334-6N	12x28	26	44	12	3
1192B to 1784B 430-3L to 430-6O	12x36	26	52	12	4
1625B to 1925B 478-3M to 478-6P	12x40	26	60	14	4
857B to 1166B 290-3K to 290-6N	24x12	26	36	10	3
1163B to 1293B 338-3L to 338-6N	24x14	26	44	12	3
1191B to 1783B 434-3L to 434-6O	24x18	26	52	12	4
1616B to 1915B 482-3M to 482-6P	24x20	26	60	14	4
1879B to 2320B 578-3K to 578-6N	24x24	26	72	20	6
2256B to 2509B 672-3L to 672-6N	24x28	26	88	24	6
2490B to 3459B 866-3L to 866-6O	24x36	26	104	24	6
2855B to 3714B 960-3M to 960-6P	24x40	26	120	28	6

NOTES:

- 3/8 x 1-1/2" (10 x 38 mm) bolt, hex nut, lockwasher, flat washer.
- 5/16 x 1" (8 x 25 mm) or 3/8 x 1" (10 x 25mm) taper. Stainless units use 5/16" (8 mm) nuts and bolts.

Table 5 – Rigging Hardware

Accessory Location Checklist

Accessories can ship in a variety of locations depending on the type of accessory, the size of the unit and the other accessories purchased with the unit. See Table 6 for a guide to accessory location.

Unit Accessories	Shipping Location
Aluminum Ladder	Shipping Location is Unit and Accessory Dependent - If Space is Available: Strapped Inside Unit Basin - If No Space is Available: Shipped Separately on Truck Bed
Cap Channels for Multi Cell Units	Strapped Inside Unit Basin
Discharge Attenuation	Shipping Location is Unit Dependent - 4' (1.2 m) Wide Units: Shipped Separately on Truck Bed - 8' (2.4 m) Wide Units and Larger: Mounted Loosely Bolted on Basin
Discharge Hood with Dampers	Shipping Location is Unit Dependent - 4' (1.2 m) Wide Units: Shipped Separately on Truck Bed - 8' (2.4 m) Wide Units and Larger: Mounted Loosely Bolted on Basin
Electric Basin Heater	Shipping Location is Unit Dependent - End Mounted Heater: Installed in Unit Basin - Side Mounted Heater: Strapped Inside Basin Section
Electric Basin Heater Control Panel	Shipping Location is Dependent on Control Panel Size - If Space is Available: Mounted on Unit Basin - If No Space is Available: Boxed, Wrapped and Wire Tied Inside Basin Section
Electric Basin Heater Low Water Cutout	Shipped in Rigging Box
Electric Basin Heater Thermostat	Shipping Location is Unit Dependent - End Mounted Thermostat: Mounted on Basin Section - Side Mounted Thermostat: Shipped in Rigging Box
Electronic Water Level Control Probes	Mounted in PVC standpipe
Electronic Water Level Control PVC Standpipe	Strapped Inside Unit Basin
External Service Platform with Ladder	Shipping Location is Unit and Accessory Dependent - If Space is Available: Strapped Inside Basin Section - If No Space is Available: Crated and Shipped Separately on Truck Bed
Factory Mounted Crossover Piping	Welded to Coil Connections
Fan Screens (If not mounted)	Shipping Location is Unit and Accessory Dependent - If Space is Available: Strapped Inside Unit Basin - If No Space is Available: Crated and Shipped Separately on Truck Bed
Fan Screen Supports (If not mounted)	Shipping Location is Unit and Accessory Dependent - If Space is Available: Strapped Inside Unit Basin - If No Space is Available: Crated and Shipped Separately on Truck Bed
Flume Plate	Mounted to Flume Box
Hot Water or Steam Coil	Installed in Unit Basin
Low Water Cutoff for Pump	Shipped in Rigging Box
Motor Davit and Base	Shipping Location is Unit and Accessory Dependent - If Space is Available: Strapped Inside Basin Section - If No Space is Available: Crated and Shipped Separately on Truck Bed
Remote Sump Trash Screen	Installed In Unit Basin
Rigging Hardware	Shipped in Rigging Box
Safety Cage	Attached to the Ladder
Sealer Tape	Shipped in Rigging Box
Splash Guards for Multi Cell Units	Strapped Inside Unit Basin
Sump Sweeper Piping with and without High Flow Eductors	Installed in Unit Basin
Vibration Isolation Rails	Shipping Location is Unit and Accessory Dependent - If Space is Available: Strapped Inside Unit Basin - If No Space is Available: Crated and Shipped Separately on Truck Bed
Vibration Switch	Mounted in Fan Section
Water Level Indicator	Strapped Inside Unit Basin
Water Silencers	Installed in Unit Basin

Table 6 – Unit Accessory Shipping Location



Notes

Lined area for notes.

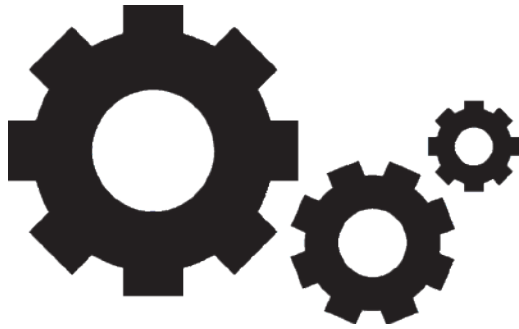

**FOR EVAPCO AUTHORIZED
PARTS AND SERVICE,
CONTACT YOUR
LOCAL EVAPCO
REPRESENTATIVE
OR THE LOCAL
SERVICE CENTER**



Mr. GoodTower®



EVAPCO, Inc. — World Headquarters & Research/Development Center

P.O. Box 1300 • Westminster, MD 21158 USA
410.756.2600 • marketing@evapco.com • evapco.com

North America

EVAPCO, Inc.
World Headquarters
Westminster, MD USA
410.756.2600
marketing@evapco.com

EVAPCO East
Taneytown, MD USA

EVAPCO East
Key Building
Taneytown, MD USA

EVAPCO Midwest
Greenup, IL USA
217.923.3431
evapcomw@evapcomw.com

Evapcold Manufacturing
Greenup, IL USA

EVAPCO Newton
Newton, IL USA
618.783.3433
evapcomw@evapcomw.com

EVAPCO West
Madera, CA USA
559.673.2207
contact@evapcowest.com

EVAPCO Alcoil, Inc.
York, PA USA
717.347.7500
info@evapco-alcoil.com

EVAPCO Iowa
Lake View, IA USA

EVAPCO Iowa
Sales & Engineering
Medford, MN USA
507.446.8005
evapcomn@evapcomn.com

EVAPCO LMP ULC
Laval, Quebec, Canada
450.629.9864
info@evapcolmp.ca

EVAPCO Select Technologies, Inc. Belmont, MI USA
844.785.9506
emarketing@evapcoselect.com

Refrigeration Vessels & Systems Corporation
Bryan, TX USA
979.778.0095
rvs@rvscorp.com

Tower Components, Inc.
Ramseur, NC USA
336.824.2102
mail@towercomponentsinc.com

EvapTech, Inc.
Edwardsville, KS USA
913.322.5165
marketing@evaptech.com

EVAPCO Dry Cooling, Inc.
Bridgewater, NJ USA
908.379.2665
info@evapcodc.com

EVAPCO Dry Cooling, Inc.
Littleton, CO USA
908.895.3236
info@evapcodc.com

EVAPCO Power México S. de R.L. de C.V.
Mexico City, Mexico
(52) 55.8421.9260
info@evapcodc.com

Asia | Pacific

EVAPCO Asia Pacific Headquarters
Baoshan Industrial Zone Shanghai, P.R. China
(86) 21.6687.7786
marketing@evapcochina.com

EVAPCO (Shanghai) Refrigeration Equipment Co., Ltd.
Baoshan Industrial Zone, Shanghai, P.R. China

EVAPCO (Beijing) Refrigeration Equipment Co., Ltd.
Huairou District, Beijing, P.R. China
(86) 10.6166.7238
marketing@evapcochina.com

EVAPCO Air Cooling Systems (Jiaxing) Company, Ltd.
Jiaxing, Zhejiang, P.R. China
(86) 573.8311.9379
info@evapcochina.com

EVAPCO Australia (Pty.) Ltd.
Riverstone, NSW, Australia
(61) 02.9627.3322
sales@evapco.com.au

EvapTech (Shanghai) Cooling Tower Co., Ltd
Baoshan District, Shanghai, P.R. China.
Tel: (86) 21.6478.0265

EvapTech Asia Pacific Sdn. Bhd.
Puchong, Selangor, Malaysia
(60) 3.8070.7255
marketing-ap@evaptech.com

Europe | Middle East | Africa

EVAPCO Europe EMENA Headquarters
Tongeren, Belgium
(32) 12.39.50.29
info@evapco.be

EVAPCO Europe BV
Tongeren, Belgium

EVAPCO Europe, S.r.l.
Milan, Italy
(39) 02.939.9041
evapcoeuropa@evapco.it

EVAPCO Europe, S.r.l.
Sondrio, Italy

EVAPCO Europe A/S
Aabybro, Denmark
(45) 9824.4999
info@evapco.dk

EVAPCO Europe GmbH
Meerbusch, Germany
(49) 2159.69560
info@evapco.de

EVAPCO Middle East DMCC
Dubai, United Arab Emirates
(971) 4.448.7242
info@evapco.ae

Evap Egypt Engineering Industries Co.
A licensed manufacturer of EVAPCO, Inc.
Nasr City, Cairo, Egypt
(20) 10.054.32.198
evapco@tiba-group.com

EVAPCO S.A. (Pty.) Ltd.
A licensed manufacturer of EVAPCO, Inc.
Isando, South Africa
(27) 11.392.6630
evapco@evapco.co.za

South America

EVAPCO Brasil
Equipamentos Industriais Ltda.
Indaiatuba, São Paulo, Brazil
(55) 11.5681.2000
vendas@evapco.com.br

FanTR Technology Resources
Itu, São Paulo, Brazil
(55) 11.4025.1670
fantr@fantr.com

TECHNOLOGY FOR THE FUTURE, AVAILABLE TODAY

Visit EVAPCO's websites: www.evapco.eu / www.mrgoodtower.eu