

CLOSED CIRCUIT COOLERS

LSWE/LRWB

eco Coolers

Environmentally
Conscious
Operation

Featuring **Water & Energy**
Conserving Technology



eco-LSWE



eco-LRWB



for LIFE



*Mark owned by the Cooling Technology Institute



Get to Know EVAPCO

- The global innovator in heat transfer solutions
- Serving the commercial HVAC, Industrial Refrigeration, Power Generation, and Industrial Processing markets
- Founded in 1976
- Employee-owned
- 22 manufacturing facilities in 10 countries
- More than 170 sales offices worldwide

Learn More Now

Visit evapco.com to download product catalogs, view complete product specifications, and more.

EVAPCO is more than a name.

It's a pledge to make everyday life easier, more comfortable, more reliable, and more sustainable for people everywhere. How do we fulfill that promise? It's simple.

We never stop innovating.

At EVAPCO, we don't just talk about innovation, it's ingrained in our workflow. Guided by our annually developed R&D plans, we set out to find groundbreaking solutions that transform the way the world works for the better. It's why we have more than 28 patents worldwide in the last 10 years alone.

We craft exceptionally built solutions.

As an employee-owned company, we take pride in our work. We are proud to be one of the most experienced teams of engineers and craftsmen in the industry. This translates into solutions that are always exceptionally built. EVAPCO has an unwavering commitment to provide "best in class" heat transfer solutions and services.

We guarantee performance.

Every EVAPCO solution is put through rigorous research and testing to ensure maximum efficiency and reliability. But we don't stop there. EVAPCO is an industry leader in independent, third-party performance certifications. These certifications guarantee our performance metrics—so that you can plan your projects with complete peace of mind.

We protect the environment.

Innovation and environmental sustainability go hand-in-hand at EVAPCO. EVAPCO's industrial heat transfer equipment not only conserves natural resources and helps reduce noise pollution, they also feature recycled steel content in their construction. Our stainless steel units are constructed of panels that contain up to 75% recycled content; over 80% in galvanized units construction. From sound reduction to water conservation to chemical elimination, we are constantly developing new technologies that deliver the ultimate operating advantages for our clients— and protect the planet for every generation that comes after us.

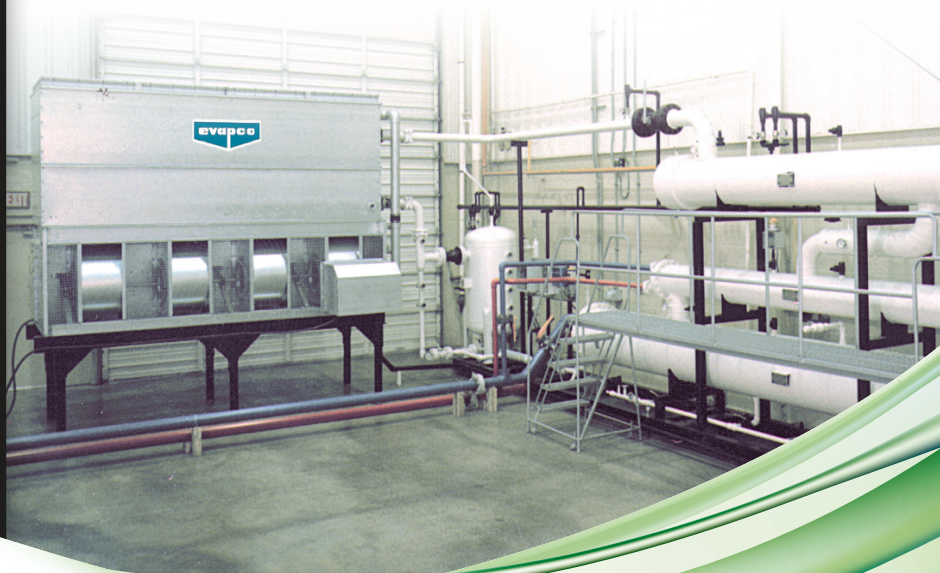

Table of Contents

Corporate	2
Principle of Operation	4
Application Versatility	5
eco-LSWE Design and Construction Features	6-7
eco-LRWB Design and Construction Features	8-9
Heat Transfer Coil	10
Motor Mount	11
Fan Access and Housing	11
Fan Assembly	11
Water Distribution System	11
Drift Eliminators	11
Sage Water & Energy Conservation Control System	12-13
EVAPCO Water Treatment Systems	14-15
eco-LSWE Stainless Steel Options	16
eco-LRWB Stainless Steel Options	17
Connections and Optional Equipment	18
Sound Reducing Options	19
eco-LSWE Discharge & Intake Attenuation	20
eco-LRWB Discharge & Intake Attenuation	21
Freeze Protection Options	22-23
Heat Loss & Discharge Hood Dimensions	24
Steel Support	25
Specific Design Features	26
General Information	27
Engineering Data	28-44

The eco-LSWE and eco-LRWB Series: The Market's Most Efficient Forced Draft Fluid Coolers

2 Forced Draft Coolers for 2 Unique Solutions

Featuring Evapco's revolutionary **Ellipti-fin** coil with **CROSSCOOL** Internal Tube Enhancement, the eco-LSWE and eco-LRWB closed circuit coolers are the most energy and water efficient forced draft coolers available in the industry. This new and improved series of coolers is the ideal solution for indoor applications, confined layouts, and low sound requirements. NOW, with Evapco's state-of-the-art spirally finned, internally enhanced coil technology, the eco-LSWE and eco-LRWB can replace existing forced draft equipment of the same boxsize and fan motor horsepower while providing additional thermal capacity!!



-LSWE

The standard for forced draft centrifugal fan designs,
Now more efficient than ever.



-LRWB

With the fan section located beside the heat transfer casing, this unit satisfies even the strictest of height requirements in a unitary, compact design.

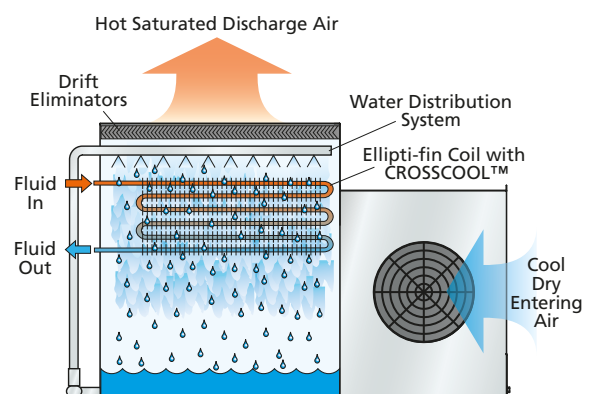
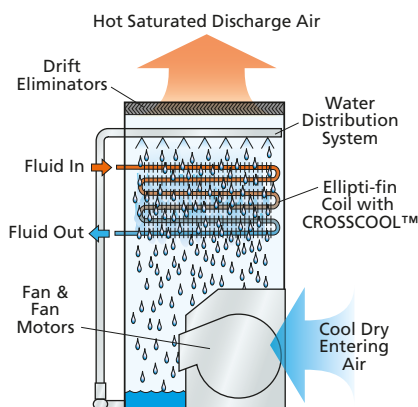

Principle of Operation

The process fluid is circulated through the coil of the closed circuit cooler. Heat from the process fluid is dissipated through the coil tubes to the water cascading downward over the tubes. Simultaneously air is blown through the unit by the fans and travels upward over the coil opposite the water flow. A small portion of the water is evaporated which removes the heat. The warm moist air is forced to the top of the closed circuit cooler by the fan and is discharged to the atmosphere. The remaining water falls to the sump at the bottom of the cooler where it is recirculated by the pump up through the water distribution system and back down over the coils.

Application Versatility

Centrifugal units are recommended for a wide range of installations. They are quiet, can easily be hidden, and are an excellent solution for installations where sound is sensitive, and when the unit must handle external static pressure.

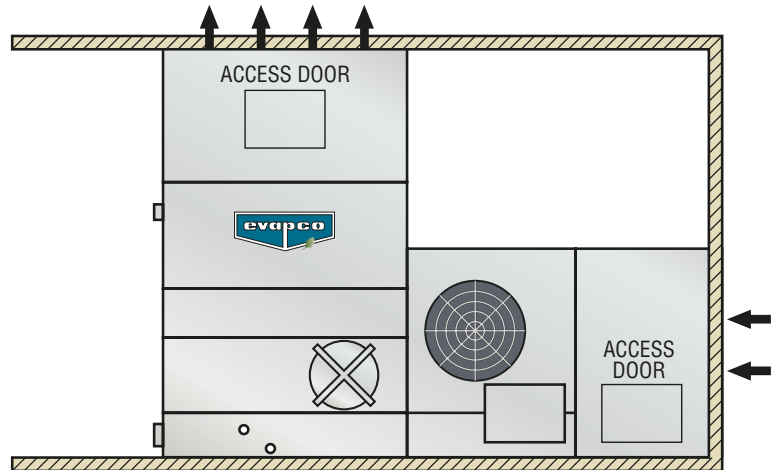
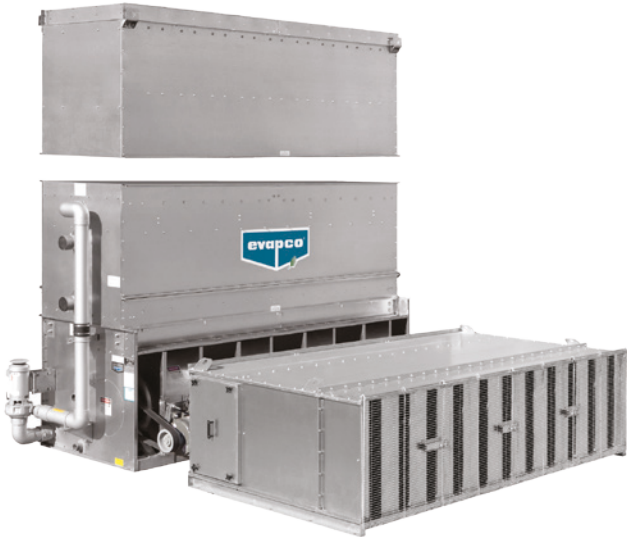

Very Quiet Operation

Centrifugal fan units operate at low sound levels which make this design preferred for installations with external static pressure where noise is a concern. Additionally, since the sound from the fans is directional, single sided air entry models can be turned away from critical areas avoiding a sound problem. When even quieter operation is necessary, centrifugal fan models can be equipped with optional sound attenuation packages. See the Sound Reducing Options section of this catalog or consult the factory for details.

In addition, the eco-LRWB features a specially engineered fan enclosure and drive system that is designed to offer very quiet operation without the high cost of external attenuation packages. The eco-LRWB fan system was developed through hundreds of hours of laboratory tests resulting in the lowest standardized sound levels available in the industry. In fact, the sound level of the eco-LRWB on average is 2 dBA quieter than competitors' similar models.

Indoor Installation

All eco-LSWE and LRWB closed circuit coolers can be installed indoors where they normally require ductwork to and from the unit. The design of the ductwork should be symmetrical to provide even air distribution across both intake and discharge openings. Guidelines for ducted applications:

- 1) The static pressure loss imposed by the ductwork must not exceed 125Pa. The fan motor size must be increased for ESP up to 125Pa.
- 2) For ducted installations, the solid bottom panel option must be ordered. On the eco-LRWB, blank off plates will also be provided in lieu of the side air inlet screens with this option.
- 3) NOTE: Access doors must be located in the ductwork (by others) for service to the fan drive components and water distribution system.

Drawings are available showing recommended ductwork connections. See EVAPCO's layout guidelines for additional information.

eco-LSWE Design & Construction Features

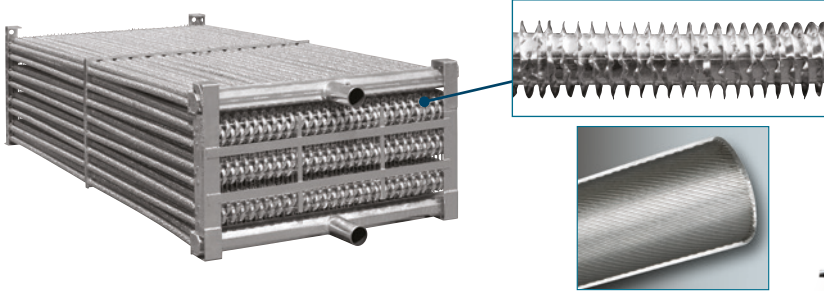

Ellipti-fin®

CROSSCOOL™
INTERNAL TUBE ENHANCEMENT

Galvanized Steel Elliptical Spiral Fin Coil featuring **CROSSCOOL™** Internal Tube Enhancement Technology

- The most efficient closed circuit cooler coil in the HVAC industry!
- Additional evaporative capacity and HIGHER dry bulb switchover temperatures
- All coil rows feature patent-pending finned Thermal-Pak® elliptical tube design
- Elliptical tube design results in lower airflow resistance than typical finned round tubes



Optional Factory Mounted Non-Chemical or Chemical Water Treatment Systems

The eco-LSWE is available with either a *Pulse~Pure*® non-chemical or a *Smart Shield*® solid chemical water treatment system. The *Pulse~Pure*® and *Smart Shield*® are environmentally sensitive alternatives for treating water in evaporative cooled equipment. The *Pulse~Pure*® and *Smart Shield*® systems include all components required for an effective water treatment system; **factory mounted and wired!**



The EVAPCO Performance Guarantee

Every eco-LSWE product is rigorously thermal performance tested by EVAPCO and then independently certified by the Eurovent Association and the Cooling Technology Institute (CTI), so you know you're getting a solution that's guaranteed to get the job done.

*Mark owned by the Cooling Technology Institute

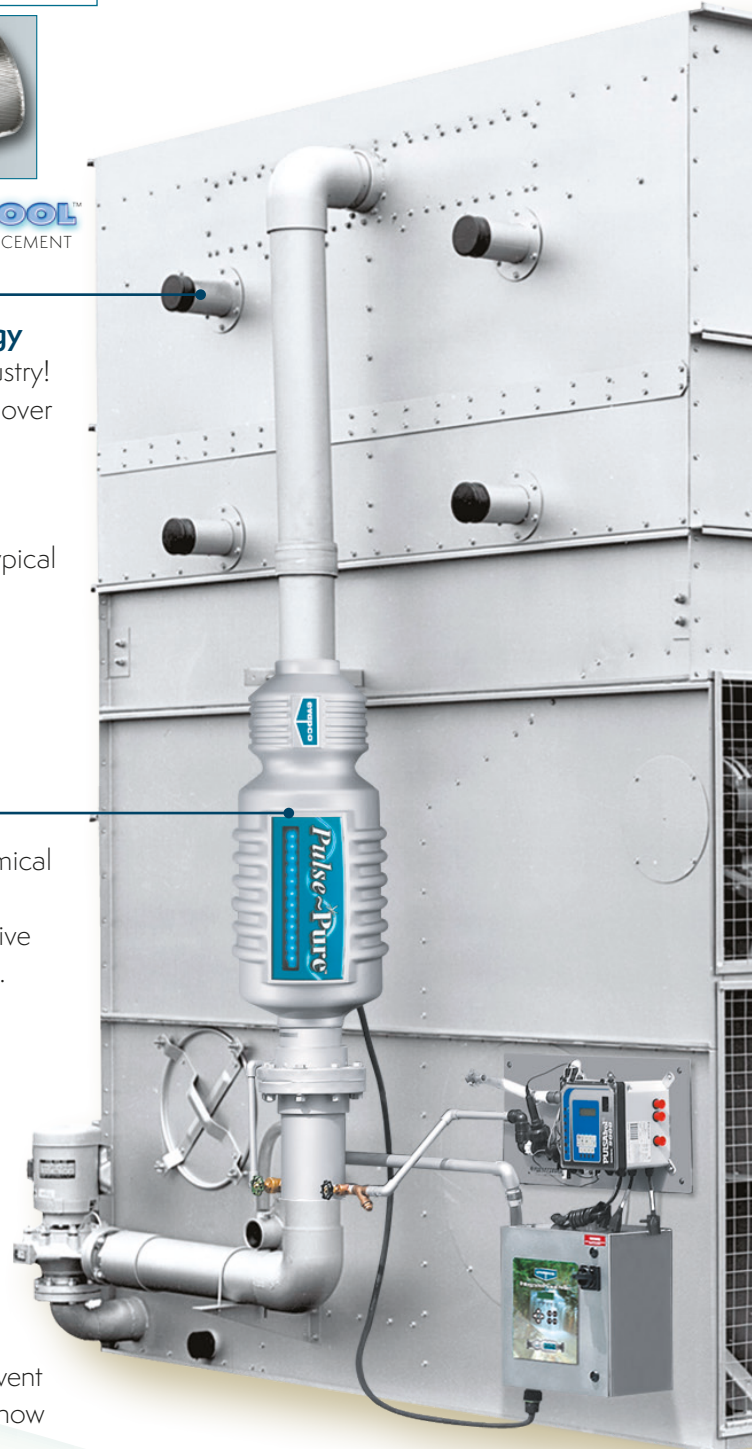

Zero Maintenance PVC Spray Distribution Header with ZM®II Nozzles

- Fixed position nozzles require zero maintenance
- Large orifice nozzles prevent clogging

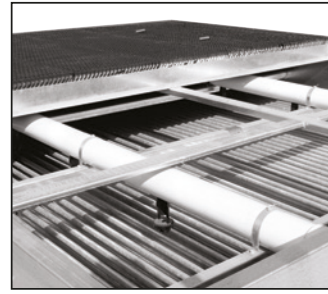

Easy Field Assembly

- Ensures easy assembly and fewer fasteners
- Incorporates self-guiding channels to guide the coil casing section into position improving the quality of the field seam

Clean Pan Design

- Sloped design allows water to drain completely from cold water basin
- Easier removal of dirt and debris



Totally Enclosed Fan Motors

- Assures long life
- All normal maintenance can be performed quickly from outside the unit
- If required, motor may be easily removed
- Motors are now located outboard on multi-motor units for even easier drive system access
- Premium efficient inverter-ready motors are standard

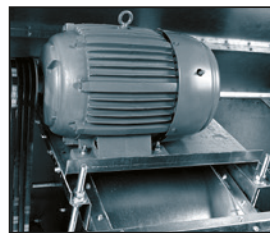

eco-LRWB Design and Construction Features

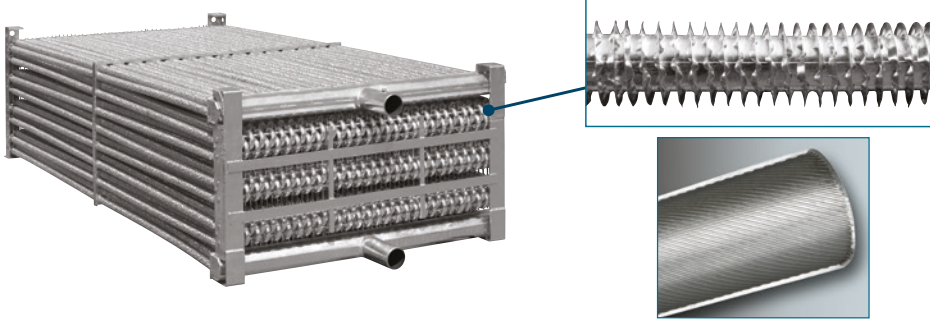

CROSSCOOL™
INTERNAL TUBE ENHANCEMENT

Ellipti-fin®

Galvanized Steel Elliptical Spiral Fin Coil featuring **CROSSCOOL™** Internal Tube Enhancement Technology

- The most efficient closed circuit cooler coil in the HVAC industry!
- Additional evaporative capacity and HIGHER dry bulb switchover temperatures
- All coil rows feature patent-pending finned Thermal-Pak® elliptical tube design
- Elliptical tube design results in lower airflow resistance than typical finned round tubes

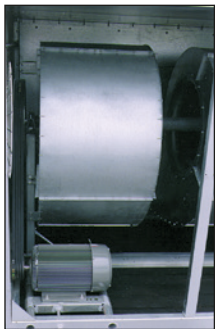

Easy to Service Motor & Drive System

- Belt tensioning and bearing lubrication can be performed from outside the unit
- Locking mechanism can also be used as a wrench to adjust the belts
- Motor is fully accessible by removing one inlet screen
- Split fan housings allow removal of all mechanical equipment through the end of the unit

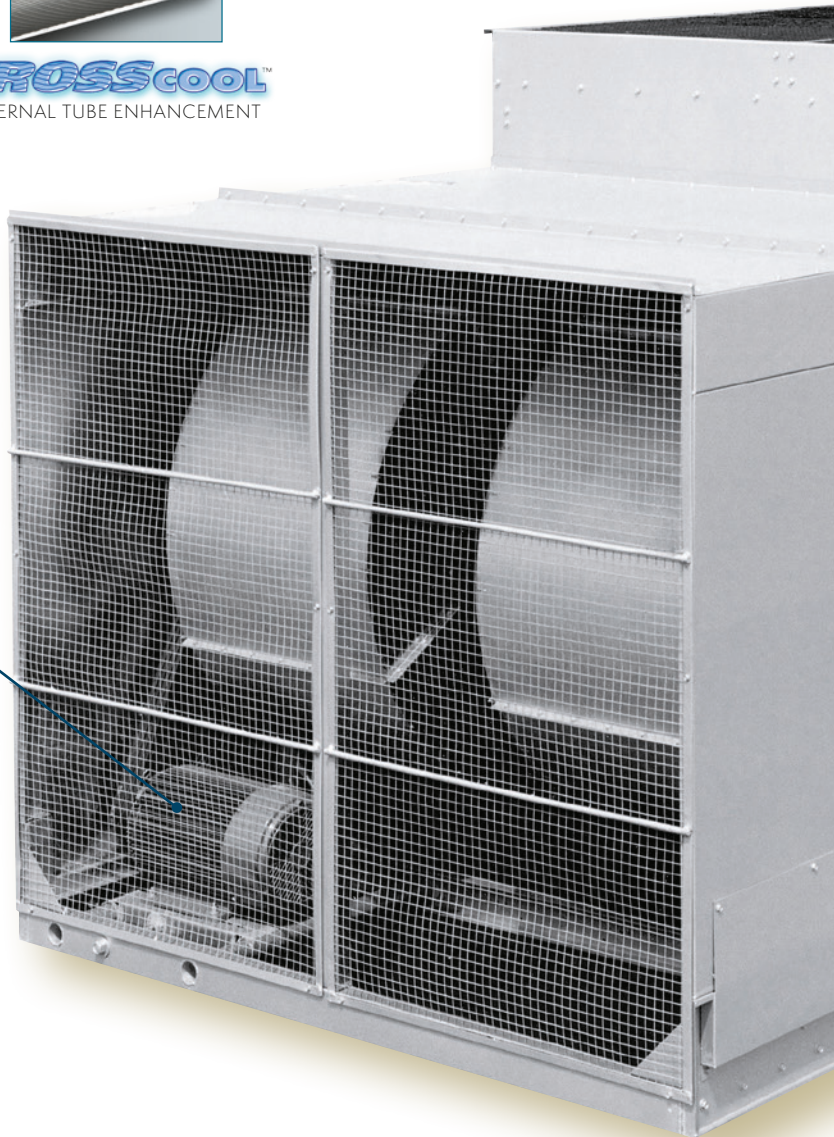

Zero Maintenance PVC Spray Distribution Header with ZM®II Nozzles

- Fixed position nozzles require zero maintenance
- Large orifice nozzles prevent clogging



Optional Factory Mounted Non-Chemical or Chemical Water Treatment Systems

The eco-LRWB is available with either a *Pulse~Pure*® non-chemical or a *Smart Shield*® solid chemical water treatment system. The *Pulse~Pure*® and *Smart Shield*® are environmentally sensitive alternatives for treating water in evaporative cooled equipment. The *Pulse~Pure*® and *Smart Shield*® systems include all components required for an effective water treatment system; **factory mounted and wired!**



The EVAPCO Performance Guarantee

Every eco-LWRB product is rigorously thermal performance tested by EVAPCO and then independently certified by the Eurovent Association and the Cooling Technology Institute (CTI), so you know you're getting a solution that's guaranteed to get the job done.

*Mark owned by the Cooling Technology Institute

Innovative Design Features

Ellipti-fin® Heat Transfer Coil

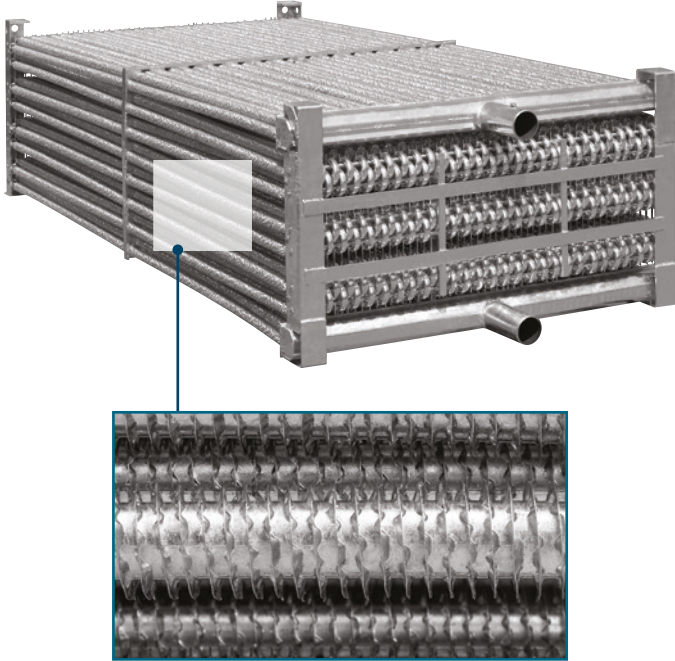

Featuring

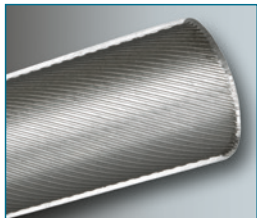

CROSSCOOL™
INTERNAL TUBE ENHANCEMENT

Galvanized steel elliptical spiral fin coil featuring **CROSSCOOL™** Internal Tube Enhancement Technology

- The most efficient closed circuit cooler coil in the HVAC Industry
- Additional evaporative capacity and HIGHER dry bulb switchover temperatures
- Patent Pending finned Thermal-Pak elliptical tube design with ALL coil rows finned
- Internal Tube Enhancement Increases Fluid Turbulence Providing Additional Evaporative Capacity
- Elliptical tube design results in lower airflow resistance than typical finned round tubes

Cooling Coil

The eco-LSWE and eco-LRWB closed circuit coolers utilize EVAPCO's patented Ellipti-fin® coil design, featuring CROSSCOOL™ internal tube enhancement, which assures even greater operating efficiency. The elliptical tube design allows for closer tube spacing, resulting in greater surface area per plan area than round-tube coil designs.

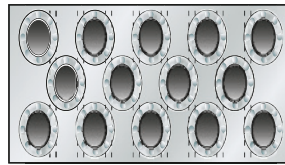

EVAPCO's Ellipti-fin®
Finned Elliptical Tube

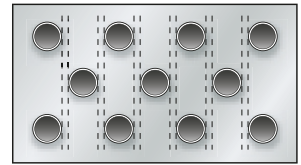

Competitors Round Tube
Coil

In addition, the revolutionary Ellipti-fin® design uses elliptical spiral fin coil technology and has lower resistance to airflow than typical finned coil designs. This permits greater water loading, and increases the evaporative and dry cooling capacity of the coil. EVAPCO's CROSSCOOL™ internal tube enhancement increases fluid turbulence through the coil, further increasing the evaporative capacity. The Ellipti-Fin coil featuring CROSSCOOL™ internal tube enhancement is the most efficient design available in the industry, providing additional evaporative capacity in the same box!

The coils are manufactured from high quality steel tubing following the most stringent quality control procedures. Each circuit is inspected to ensure the material quality and then tested before being assembled into a coil. Finally, the assembled coil is pneumatically tested at 15 barg under water to ensure it is leak free.

To protect the coil against corrosion, it is placed in a heavy steel frame and then the entire assembly is dipped in molten zinc (hot-dip galvanized) at a temperature of approximately 427°C.

Note: Closed circuit coolers should only be used on sealed, pressurized systems. Continual aeration of the water in an open system can cause corrosion inside the tubes of the coil leading to premature failure.

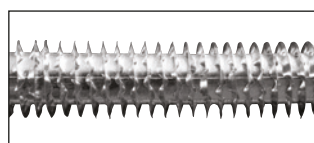

Ellipti-fin®
Finned Elliptical Tube

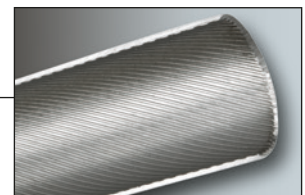

CROSSCOOL™
INTERNAL TUBE ENHANCEMENT

Innovative Design Features

Fan Motor Mount

TEFC fan motors are mounted in a convenient open area for ease of belt tensioning, motor lubrication and electrical connection. The motor base is designed for easy adjustment and is locked into position to maintain proper belt tension.

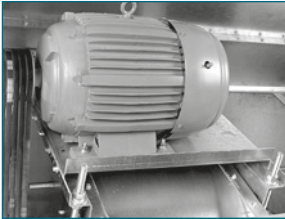

Example eco-LSWE Fan Motor Mount

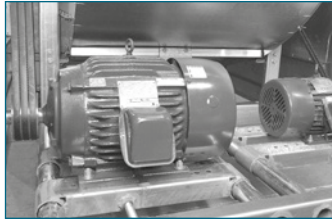

eco-LRWB Fan Motor Mount (shown with optional pony motor)

Fan Access-Split Housing

Another unique feature of the eco-LRWB closed circuit cooler is the split fan housing. The split fan housing on the eco-LRWB allows quick removal of the fans from the front end of the unit. This feature allows fan removal when units are placed side by side where space is minimal.



Mechanical Drive System Access

The eco-LSWE and eco-LRWB mechanical drive systems are easy to maintain. Bearing lubrication and belt adjustment can be performed from outside the unit. There is no need to remove fan screens to maintain important drive components. In addition, the locking mechanism used to maintain belt tension can also work as a wrench to adjust the belt.

Centrifugal Fan Assembly

Fans on eco-LSWE and eco-LRWB closed circuit coolers are of the forward curved centrifugal design with hot-dip galvanized steel construction. All fans are statically and dynamically balanced and are mounted in a hot-dip galvanized steel housing.

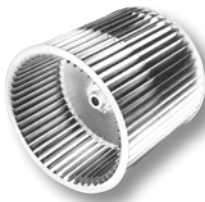

Maintenance Free ZM®II Spray Nozzle Water Distribution System

EVAPCO'S Zero Maintenance ZM®II spray nozzle remains clog-free while providing even and constant water distribution for reliable, scale-free evaporative cooling under all operating conditions.



ZM®II Nozzle

The heavy duty nylon ZM®II spray nozzles have a 33 mm diameter opening and a 38 mm splash plate clearance. Furthermore, the fixed position ZM®II nozzles are mounted in corrosion-free PVC water distribution pipes. Together, these elements combine to provide unequalled coil coverage and scale prevention, and make the industry's best performing non-corrosive, maintenance-free water distribution system.

Efficient Drift Eliminators

The eco-LSWE and eco-LRWB are provided with an efficient drift eliminator system that effectively reduces entrained water droplets from the air discharge to less than 0.001% of the spray water flow rate.

The eliminators are constructed of non-corrosive PVC with a multi-pass design for maximum drift reduction. They are assembled in modular sections for easy removal and access to the water distribution system.

In addition to reducing drift, the eliminators also function as effective debris screens which protect the spray system from sunlight and debris.

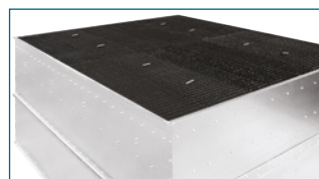

eco-LSWE and eco-LRWB Drift Eliminator



Drift Eliminators Removed for Coil Inspection

Sage[®] Water and Energy Conservation Control System



The eco-LSWE and eco-LRWB closed circuit cooler is optional with the EVAPCO Sage2[®] Control System. This system operates the unit in a manner which will maximize water or energy savings. Control is accomplished by operating each cell of the eco-LSWE and eco-LRWB in the Evaporative Mode or Dry Mode based on water or energy savings priority.

The Sage2[®] control system contains a Programmable Logic Controller (PLC) with adaptive logic, which allows the operator to select either a priority for maximizing water or energy efficiency. Real time load and weather data are measured and recorded by the PLC and sensors. This data is then analyzed and used to switch the unit between the various modes of operation in order to maximize water or energy savings. If the panel is set to operate in the water savings priority, the Sage Panel will vary the unit between the Dry and Evaporative modes of operation, limiting the time spent in the evaporative mode to maximize water savings. If the panel is set to operate in the energy savings priority, the Sage Panel will switch the unit between the Dry & Wet modes of operation, controlling the fan speed and pump operation in an effort to maximize energy savings.

Standard Control & Power Items

- MODBUS 485 Port
- NEMA 4
- UL Approval
- Programmable Logic Control
- Variable Frequency Drive(s)
- Recirculating Pump Motor Starter(s)
- Fluid Inlet/Outlet Temperature Sensors with High and Low Alarm Set Points
- Basin Temperature Sensor(s)
- Ambient Dry Bulb Sensor
- Main Disconnect Circuit Breaker
- Main Hand/Off/Auto Switch (HOA)
- DC Power Supply for the PLC and Instruments
- Control Power Transformer
- Heater Contactor with Overload Protection and Temperature Set Points with Fusing
- 5-Probe Electronic Water Level Control Package
- High/Low Water Level Alarm Contacts
- Fan Motor: Space Heater Control(s)
- Relays for all PLC Digital Outputs
- Terminal Blocks for each PLC input/output
- Ethernet Connection between VFD(s), PLC and Operator Interface



Control Features

- Manual Operation of Pumps and Fans
- Ability to Enable or Disable Make-Up Valve
- Power Failure Recovery Timer
- Ability to Perform Bump Test
- Visual Status Display of All Unit Components and Accessories
- Contacts and Counter To Record Water Usage
- Contacts and Analog Signal for (Customer Supplied) Conductivity Meter
- Backup with User Settings and Factory Settings
- Pump Run Time Recorder
- Fan Motor Run Time Recorder

Sage[®] Water and Energy Conservation Control System

HMI Panel Display

All Sage2 Control Panels are provided with a 10" touch screen operator interface with a color display. This allows for easy viewing and control at the panel.

Easy-to-use Touch Screen Navigation

The panel boasts an easy to navigate menu which will allow the user to control each cell independently from other units and gather useful run time information at the unit.



Alarm Setpoints Screen



Plan View Screen



End View Screen

HMI Enclosure

The display screen is encased by a solid enclosure. This enclosure protects the HMI display from the elements.



Temperature Sensors (Field Installed)

Four separate temperature data points are monitored with this package.

- Inlet Temperature Sensor: 0°C - 100°C range
- Outlet Temperature Sensor: 0°C - 100°C range
- Dry Bulb Temperature Sensor: -34°C - 54°C
- Basin Temperature Sensor: 0°C - 100°C range



Heater

Climate Controlled Enclosure

The panel enclosure includes an intake and an exhaust ventilation fan or air conditioner dependent on project location. When the enclosure temperature rises to a predetermined set point, the exhaust fans or air conditioner are activated. The enclosure also contains a heater. The heater eliminates the drastic temperature changes which could create condensation inside of the enclosure.



Fan



*Optional Communication Protocol May Be Available. Please Contact Your Local Sales Representative.

EVAPCO Water Systems



The eco-LSWE and eco-LRWB are available with EVAPCO's factory-mounted water treatment systems, Smart Shield® or Pulse~Pure®. These systems will help maintain your heat transfer efficiency and extend the life of the cooler.

Specifically designed for each closed circuit cooler, our systems provide owners a single source of responsibility for equipment, water treatment and service. Both products are manufactured and warranted by EVAPCO. More about Smart Shield® and Pulse~Pure® can be found at right.

- **SAVE MONEY** by simplifying equipment commissioning:
 - Single power connection is the only field installation requirement.
- **Factory mounting** your water treatment system ensures that it is installed to factory specifications.
- **Patented self-draining piping** eliminates the need for line insulation and heat tracing above the overflow level.
- **A factory authorized service partner** provides the first year of water system service and monitoring, to ensure proper operation and ongoing success.
- **Conductivity control package** maximizes water efficiency and features:
 - Low maintenance non-fouling torodial probe
 - USB port for downloadable 60 day audit trail of system operation
 - Motorized blowdown valve that provides the most reliable bleed control with power open/spring return operation

EVAPCO Water Systems



Smart Shield® Solid Chemical Water Treatment System

Proven solid chemistry! A revolutionary feed system! Together, these make Smart Shield®, the easiest and safest chemical water treatment system available today, featuring:

- A patented, controlled-release scale and corrosion inhibitor that is fed whenever your spray water pump is operating.
- A solid chemistry design that eliminates liquid chemical hazards—including spills—and the need for expensive feed pumps.
- 'Bag in bag' no-touch chemical replenishments for easier, safer reloads and disposal.
- Reduced packaging, shipping, and handling for a lower carbon footprint than liquid chemical options.



Watch a short product video at smartshield.evapco.com.



Pulse~Pure® Non-Chemical Water Treatment System

Pulse~Pure® from EVAPCO uses pulsed electric field technology to treat your water without chemicals. It's the environmentally responsible solution that also packs a powerful water-treating punch:

- Emits short, high frequency bursts of low energy electromagnetic fields to recirculating water.
- Delivers a guaranteed maximum bacterial count of 10,000 CFU/ml in the cooling water.
- Controls scale, corrosion, and microbiological growth with absolutely no chemicals required.
- Compact design eliminates moving parts and ensures low energy consumption.



Learn more about Pulse~Pure® at evapco.com.

Stainless Steel Material Options

All eco-LSWE and eco-LRWB Series units are constructed with galvanized steel panels as standard. The following pages illustrate the available stainless steel construction material options for this series. Stainless steel options are available in both 304L and 316L stainless steel. Selection of these options only changes the sheet steel; optional accessories such as attenuation, discharge hoods, platforms, etc. are available in stainless steel only by special order. Stainless steel discharge hoods/attenuation have galvanized dampers with a stainless steel linkage. Accessories, coils, and fan shafts **do not** change to stainless steel with these options and are upgraded separately. The strainer in the basin is always 304L stainless steel independent of basin construction.



Stainless Steel Basin up to Overflow Level Option

Includes Type 304L stainless steel basin panels up to the overflow level. All panels above the overflow, including the fan discharge cowls are Z-725 galvanized steel. Centrifugal fan wheels are **not available** in stainless steel.

This is the first stage of stainless steel on the LS Series units 1,5 m wide and larger. This is not available on 1,2 m wide units.



Stainless Steel Water Touch Basin

All panels in the pan section in contact with the cooling water including the fan discharge cowls are constructed of Type 304L stainless steel. Remainder of unit constructed of Z-725 galvanized steel. All models with this option are furnished with epoxy coated fan wheels and shafts coated with a rust inhibitor. Centrifugal fan wheels are **not available** in stainless steel.



Stainless Steel Water Touch Unit

All panels in contact with the cooling water including the upper casing panels are constructed of Type 304L stainless steel. All models with this option are furnished with epoxy coated fan wheels and shafts coated with a rust inhibitor. Centrifugal fan wheels are **not available** in stainless steel.

This option designates the entire water section as stainless. Note that the fan housings and supports are still galvanized in this option.

Note: eco-LSWE models, with Ellipti-fin® and CROSSCOOL™, are only available with carbon steel coils which are hot dip galvanized after fabrication as standard



All Stainless Steel Except Fans Option

All panels including the fan housings and supports are constructed of Type 304L stainless steel. All models with this option are furnished with epoxy coated fan wheels and shafts coated with a rust inhibitor. Centrifugal fan wheels are **not available** in stainless steel. With this option, all sheet metal is stainless including the fan housings and supports.

Note: eco-LSWE models, with Ellipti-fin® and CROSSCOOL™, are only available with carbon steel coils which are hot dip galvanized after fabrication as standard



Stainless Steel Material Options



Stainless Steel Cold Water Basin

All EVAPCO eco-LRWB units come with a **Standard Stainless Steel Cold Water Basin**, which consists of the lowest section of the unit as highlighted in the photograph to the right. On all eco-LRWB units, the fan side inlet screens are PVC coated. Fan Screens are galvanized.

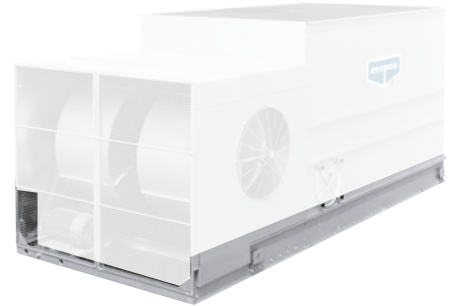

Stainless Steel Water Touch Basin

All panels in the pan section in contact with the cooling water including the fan discharge cowls are constructed of Type 304L stainless steel. Remainder of unit constructed of Z-725 galvanized steel. All models with this option are furnished with epoxy coated fan wheels and shafts coated with a rust inhibitor. Centrifugal fan wheels are **not available** in stainless steel. Fan Screens are galvanized.

Looking again at the model, this option increases the amount of stainless steel in the basin, including the access doors.

Note: eco-LRWB models have carbon steel coils, which are hot dip galvanized after fabrication as standard.

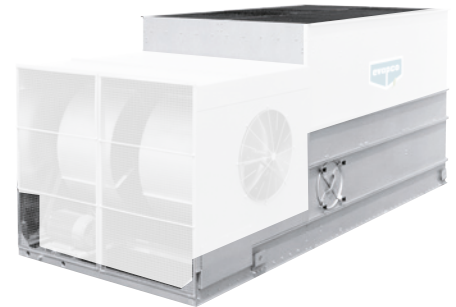

Stainless Steel Water Touch Unit

All panels in contact with the cooling water including the upper casing panels are constructed of Type 304L stainless steel. All models with this option are furnished with epoxy coated fan wheels and shafts coated with a rust inhibitor. Centrifugal fan wheels are **not available** in stainless steel. Fan Screens are galvanized. This option designates the entire water section as stainless.

Note: eco-LRWB models, with Ellipti-fin® and CROSSCOOL™, are only available with carbon steel coils which are hot dip galvanized after fabrication as standard

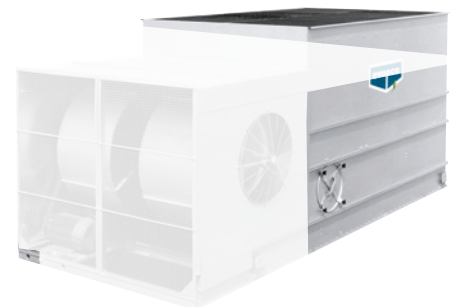

All Stainless Steel Option (Excluding Fans/Coils)

All panels including the fan housings and supports are constructed of Type 304L stainless steel. All models with this option are furnished with epoxy coated fan wheels and shafts coated with a rust inhibitor. Centrifugal fan wheels are **not available** in stainless steel. With this option, all sheet metal is stainless including the Fan Housings and Supports. Fan Screens are stainless steel.

Note: eco-LRWB models, with Ellipti-fin® and CROSSCOOL™, are only available with carbon steel coils which are hot dip galvanized after fabrication as standard



Coil Connection Options

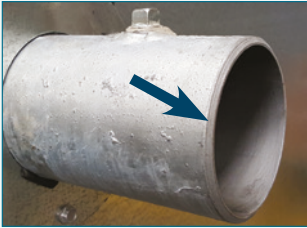

Beveled For Weld (BFW) Coil Connections

EVAPCO Closed Circuit Coolers are provided with Beveled For Weld (BFW) coil connections as standard. Beveled edges simplify field welding and allow welds to fully penetrate.



Optional Factory Mounted Crossover Piping

Some EVAPCO Closed Circuit Coolers are design for "series flow" coil operation where the coils inside of one cell are operated in series. These units are denoted by a "-Z" following the unit model number. These units require "crossover piping" from one coil to the other. Crossover piping is factory mounted as per standard for simplified field installation.

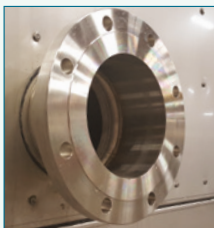

Optional Flanged Coil Connections

Flat Flanged connections can be provided as an optional coil connection (DIN2576 as per standard). The flanged coil connection allows for faster and easier field piping to a mating flanged connection. Alternative type of flanges can be provided in some cases. Please see your local sales representative.



Optional Nitrogen Charged Coils

For projects requiring long term storage or ocean freight, coils can be nitrogen charged at the factory to prevent corrosion inside of the coil circuits.

Sound Reducing Options

Sound Attenuation Packages

The centrifugal fan design of the eco-LSWE and LRWB models operate at lower sound levels which make these units preferable for installations where noise is a concern. For sound-sensitive applications, the eco-LSWE and LRWB centrifugal fan models may be supplied with various stages of intake and/or discharge attenuation packages which further reduce sound levels.

Consult the factory for certified sound data for each sound attenuation option.

Fan Side Inlet Attenuation (eco-LRWB Only)

Reduces sound radiated from the fan side air intakes and has an open side to allow for air entry. **This attenuation package ships loose to be mounted in the field on each side of the closed circuit cooler over the fan intakes.**

Fan End Inlet Attenuation

Reduces sound radiated through the end air intakes. It consists of baffled panels that change the path of the air entry and capture the radiated noise thus reducing the overall sound levels generated. In addition, the external belt adjustment mechanism is extended through the inlet attenuator to allow for easy adjustment without having to enter the unit. Solid bottom panels are included with this option to force the inlet air through the attenuator.

Discharge Attenuation

The discharge attenuation hood features a straight-sided design with insulated baffles to reduce the overall sound levels of the discharge air. The discharge attenuation incorporates a large access panel to allow entry to the drift eliminators and water distribution system. If a higher discharge velocity is required with minimal sound attenuation, a tapered discharge hood is available.

Straight Sided Discharge Attenuation
(eco-LSWE and LRWB)

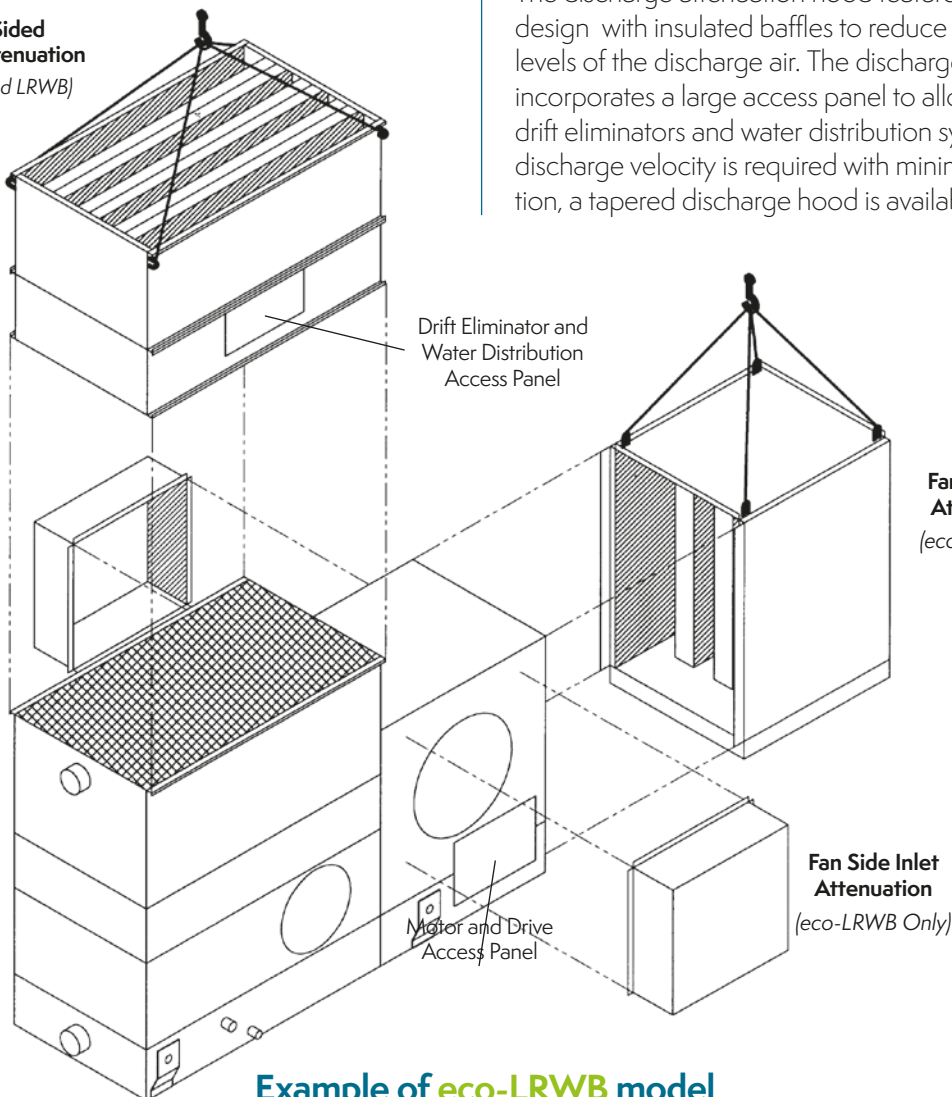

Example of eco-LRWB model

eco-LSWE Discharge & Intake Attenuation

eco-LSWE Discharge Attenuation Dimensions*

Box size	H1 (mm)	L1 (mm)	W1 (mm)	Width 1130 mm Compact (kg)	Width 1397 mm Basic (kg)	Width 1797 mm Extended (kg)	Number of Attenuators
4 x 6	1.194	1.826	1.156	275	345	445	1
4 x 9	1.194	2.724	1.156	395	485	610	1
4 x 12	1.194	3.645	1.156	510	615	775	1
4 x 18	1.194	5.486	1.156	795	935	1145	1
5 x 12	1.194	3.645	1.572	625	710	840	1
5 x 18	1.194	5.486	1.572	965	1075	1235	1
8P x 12	1.813	3.651	2.343	825	965	1175	1
8P x 18	1.813	5.486	2.343	1255	1440	1715	1
8P x 24	1.813	3.651	2.343	1650	1920	2320	2
8P x 36	1.813	5.486	2.343	2545	2880	3395	2
3M x 12	1.813	3.645	3.023	915	1055	1260	1
3M x 18	1.813	5.486	3.023	1245	1485	1835	1
3M x 24	1.813	3.645	3.023	1840	2105	2490	2
3M x 36	1.813	5.486	3.023	2850	3165	3640	2

eco-LSWE Intake Attenuation Dimensions*

Box size	H2 (mm)	L2 (mm)	W2 (mm)	Width 1130 mm Compact (kg)	Width 1397 mm Basic (kg)	Width 1797 mm Extended (kg)	Number of Attenuators
4 x 6	1.010	1.895	1.816	275	345	445	1
4 x 9	1.010	2.819	1.816	395	485	610	1
4 x 12	1.010	3.740	1.816	510	615	775	1
4 x 18	1.010	5.582	1.816	795	935	1145	1
5 x 12	1.175	3.740	1.816	625	710	840	1
5 x 18	1.175	5.582	1.816	965	1075	1235	1
8P x 12	2.070	3.743	1.816	825	965	1175	1
8P x 18	2.070	5.582	1.816	1255	1440	1715	1
8P x 24	2.070	3.693	1.816	825	960	1160	2
8P x 36	2.070	5.534	1.816	1270	1440	1695	2
3M x 12	2.261	3.747	1.816	915	1055	1260	1
3M x 18	2.261	5.588	1.816	1245	1485	1835	1
3M x 24	2.261	3.696	1.816	920	1050	1245	2
3M x 36	2.261	5.540	1.816	1425	1585	1820	2

* Attenuation dimensions may vary slightly from catalog. See factory certified prints for exact dimensions.

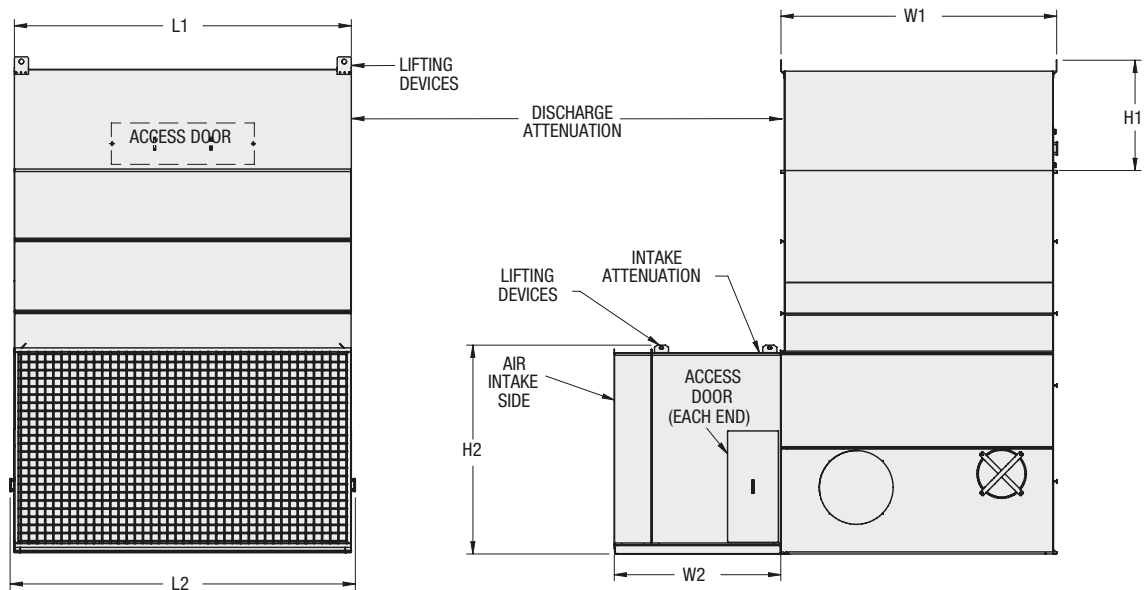

eco-LSWE Attenuation

Note: Intake sound attenuation must be fully supported. If the recommended steel support is being used a third "I" beam is required for the intake attenuation. Refer to page 24.

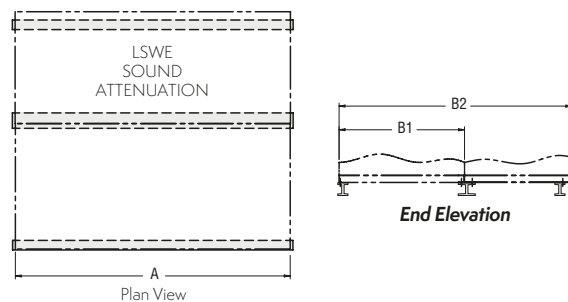

eco-LRWB Discharge & Intake Attenuation

eco-LRWB Discharge Attenuation Dimensions*

Coil Casing Footprint	H1 (mm)	L1 (mm)	W1 (mm)	Weight per Attenuator (kg)	Number of Attenuators
3' x 6'	1153	1,822	1,029	195	1
5' x 6'	1153	1,810	1,540	240	1
5' x 9'	1153	2,724	1,540	327	1
5' x 12'	1153	3,648	1,540	417	1
8' x 9'	1153	2,724	2,388	440	1
8' x 12'	1153	3,648	2,388	558	1

eco-LRWB Fan End Attenuation Dimensions*

Coil Casing Footprint	H2 (mm)	L2 (mm)	W2 (mm)	Weight per Attenuator (kg)	Number of Attenuators
3' x 6'	1,622	1,108	1,029	204	1
5' x 6'	2,022	1,105	1,540	313	1
5' x 9'	2,022	1,105	1,540	313	1
5' x 12'	2,022	1,105	1,540	313	1
8' x 9'	2,022	1,108	2,394	417	1
8' x 12'	2,022	1,108	2,394	417	1

eco-LRWB Fan Side Attenuation Dimensions*

Coil Casing Footprint	H3 (mm)	L3 (mm)	W3 (mm)	Weight per Attenuator (kg)	Number of Attenuators
3' x 6'	854	883	1,645	68	2
5' x 6'	937	1,372	2,156	104	2
5' x 9'	937	1,372	2,156	104	2
5' x 12'	937	1,372	2,156	104	2
8' x 9'	1,076	1,121	3,010	104	2
8' x 12'	1,076	1,121	3,010	104	2

* Attenuation dimensions may vary slightly from catalog. See factory certified prints for exact dimensions.

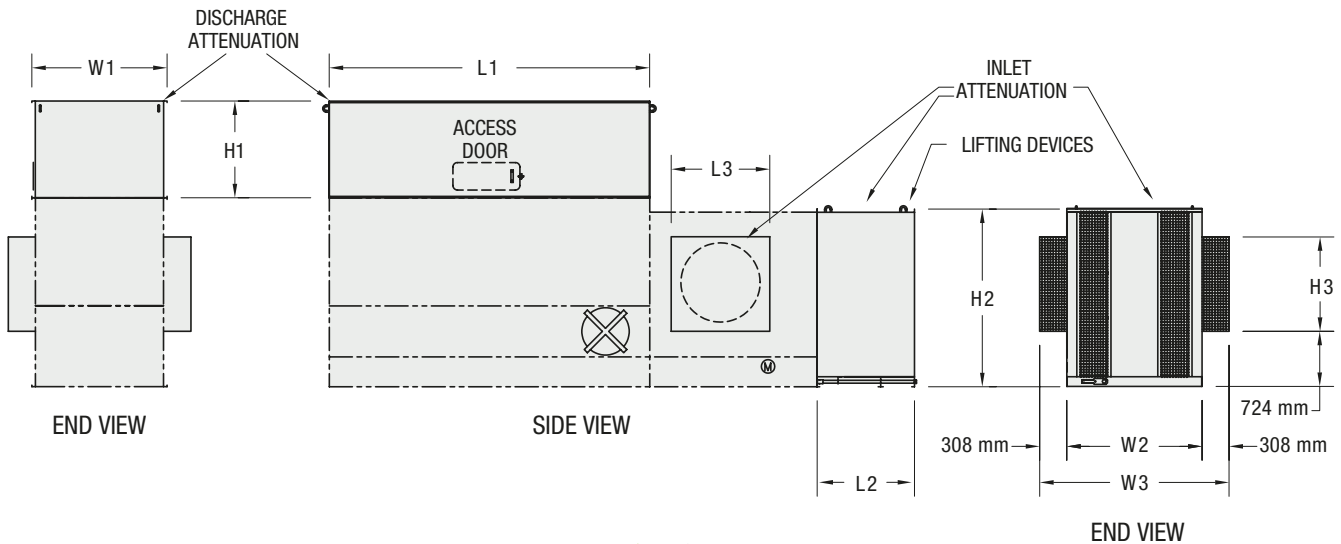

eco-LRWB Attenuation

Note: Intake sound attenuation must be fully supported. If the recommended steel support is being used, extended "I" beams are required for the intake attenuation. Refer to page 24.

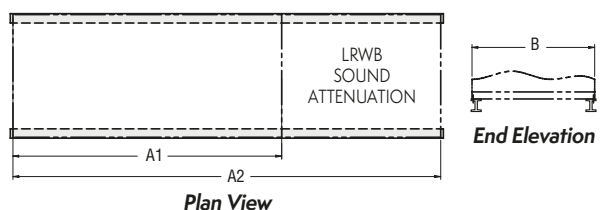

Freeze Protection and Heat Loss

Freeze Protection

If the units are installed in a cold climate and operated year-round, freeze protection must be provided for the heat exchanger coil in the unit as well as for the recirculating water system.

Recirculating Water System Freeze Protection Options

Remote Sump Configuration

The surest way to protect the recirculating water system from freezing is with a remote sump. The remote sump should be located inside the building and below the unit. When a remote sump arrangement is selected, the spray pump is provided by others and installed at the remote sump. All water in the closed circuit cooler basin should drain to the remote sump when the spray pump cycles off.

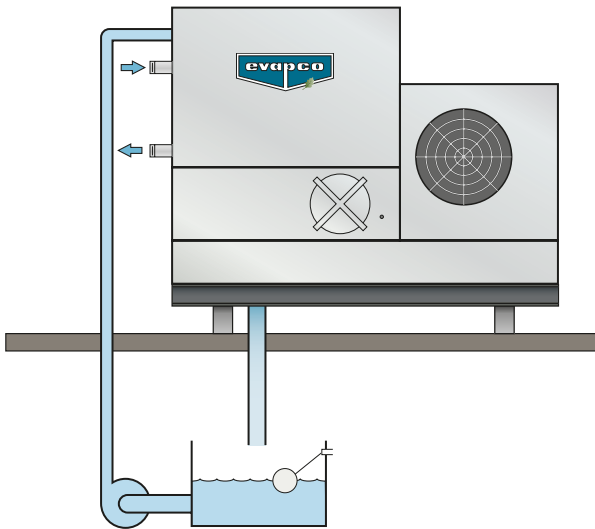

Steam/Hot Water Coils

Steam or hot water coils are available as an alternate to using electric basin heaters or a remote sump. Constructed of galvanized pipe and installed in the closed circuit cooler basin, and are ready for piping to an external hot water source. **Controls for steam/hot water coils are provided by others and should be interlocked with the water circulating pump to prevent their operation when the pump is energized.**

Basin Heater Package

If a remote sump configuration is not practical, electric basin heater packages are available to keep the pan water from freezing when the unit cycles off. Water lines to and from the unit, spray pump and related piping should be heat traced and insulated up to the overflow level to protect from freezing. Basin heaters should be interlocked with the water circulating pump to prevent their operation when the pump is energized.

This unit should not be operated dry (fans on, pump off) unless the basin is completely drained or the heaters have been oversized and the unit has been designed for dry operation. Consult the factory when dry operation is a requirement.

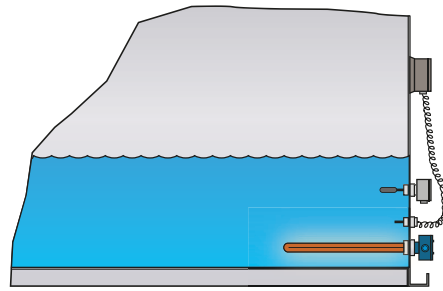

eco-LSWE Basin Heater Sizing

Unit Footprint	kW (-18°F)	kW (-28°C)	kW (-40°C)
4' x 6'	(1) 2	(1) 3	(1) 4
4' x 9'	(1) 3	(1) 4	(1) 5
4' x 12'	(1) 3	(1) 5	(1) 7
4' x 18'	(1) 5	(1) 7	(1) 9
5' x 12'	(1) 4	(1) 6	(1) 8
5' x 18'	(2) 3	(2) 4	(1) 12
8P' x 12'	(1) 5	(1) 8	(1) 10
8P' x 18'	(2) 4	(2) 6	(2) 7
8P' x 24'	(2) 5	(2) 7	(2) 10
8P' x 36'	(2) 7	(2) 12	(2) 15
10' x 12'	(1) 7	(1) 10	(1) 15
10' x 18'	(2) 5	(2) 7	(2) 10
10' x 24'	(2) 7	(2) 10	(2) 15
10' x 36'	(2) 10	(4) 7	(4) 9

eco-LRWB Basin Heater Sizing

Unit Footprint	kW (-18°F)	kW (-28°C)	kW (-40°C)
3' x 6'	(1) 2	(1) 3	(1) 4
5' x 6'	(1) 3	(1) 5	(1) 6
5' x 9'	(1) 4	(1) 6	(1) 8
5' x 12'	(1) 6	(1) 8	(1) 12
8' x 9'	(1) 7	(1) 9	(1) 12
8' x 12'	(1) 9	(1) 12	(1) 16

Freeze Protection and Heat Loss

Heat Exchanger Coil Freeze Protection Options

The simplest and most foolproof method of protecting the heat exchanger coil from freeze-up is to use a glycol solution. If this is not possible, an auxiliary heat load must be maintained on the coil at all times so that the water temperature does not drop below 10°C when the cooler is shut down and, a minimum recommended flow rate per unit as shown in the table below must be maintained. Refer to Heat Loss Data Table on page 24 for heat loss data.

eco-LSWE Minimum Flows for Freeze Protection

Unit Footprint	Minimum Flow for Freeze Protection	
	Standard Unit (l/s)	Series Flow Unit (-Z) (l/s)
4' x 6'	4,16	2,08
4' x 9'	4,16	2,08
4' x 12'	4,16	2,08
4' x 18'	4,16	2,08
5' x 12'	5,93	2,97
5' x 18'	5,93	2,97
8P' x 12'	9,34	4,67
8P' x 18'	9,34	4,67
8P' x 24'	18,67	9,34
8P' x 36'	18,67	9,34
10' x 12'	11,86	5,93
10' x 18'	11,86	5,93
10' x 24'	23,72	11,86
10' x 36'	23,72	11,86

eco-LRWB Minimum Flows for Freeze Protection

Coil Casing Footprint	Minimum Flow for Freeze Protection	
	Standard Unit (l/s)	Series Flow Unit (-Z) (l/s)
3' x 6'	3,79	1,89
5' x 6'	5,93	2,97
5' x 9'	5,93	2,97
5' x 12'	5,93	2,97
8' x 9'	9,34	4,67
8' x 12'	9,34	4,67

If an anti-freeze solution is not used, the coil must be drained immediately whenever the pump is shut down or flow stops. Care must be taken to ensure that the piping is sized to allow the water to flow quickly from the coil. This method of freeze control should only be used in an emergency situation. Coils should not be drained for an extended period of time. Leaving the coil drained and open to the atmosphere can cause corrosion inside the tubes which may lead to premature coil failure.

The amount of glycol required for a system will depend upon the total volume of water in the closed loop and the winter ambient conditions for the installation. The engineering data tables presented on pages 27-43 provide the water volume contained inside the cooler coils to assist in this calculation.

Discharge Hoods with Positive Closure Dampers

When a closed circuit cooler is used in a water-to-air heat pump system or in certain process cooling applications, a method of reducing the heat loss during idle periods of wintertime operation may be required. **For these cases, an optional discharge hood with positive closure dampers and damper actuator is available.**

The discharge hood with dampers is designed to minimize the heat loss from convective airflow through an idle cooler. Further reductions in heat loss may be obtained with the addition of insulation to the hood and casing, minimizing conductive heat losses. **Optional insulation may be factory-installed on the hood and casing or field-installed by an insulation contractor.**

The discharge hood and dampers are constructed of hot-dip galvanized steel as standard. Hoods are equipped with access panels to facilitate maintenance on the eliminators and water distribution system. The dampers, damper actuator and linkage are all factory-assembled. **Actuator controls and wiring are field-supplied by others. Damper actuators require 230V power supply. Stainless steel discharge hoods with galvanized positive closure dampers are available as an optional accessory.**

The system control sequence should provide for dampers to be fully open before the fans are running and closed when the fans are off; the damper actuator must be interlocked with the temperature control system for this purpose. **When a tapered discharge hood is specified, the next larger size fan motor must be used to overcome the additional static pressure.**

Heat loss data is provided for standard units without hoods, with hoods and with hoods and insulation. Table ratings are based on 10°C water in the coil, -23°C ambient and 72 km/h winds (fan and pump off).

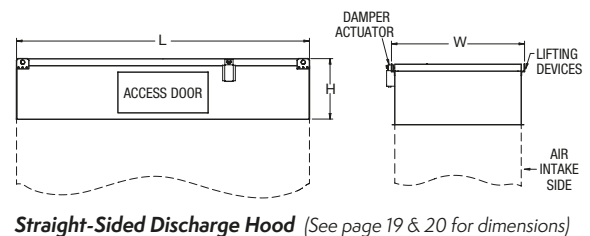
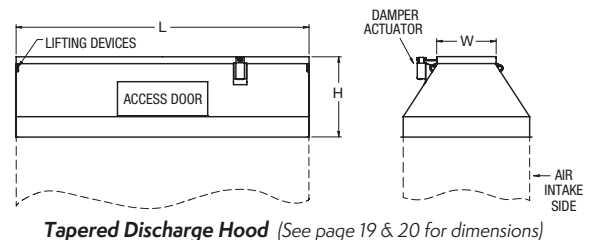

Heat Loss

eco-LSWE Heat Loss Data

LSWE Model	Standard Unit (kW)	Unit with Hood (kW)	With Hood & Insulation (kW)
4-2x6	11	8	6
4-3x6	15	10	6
4-4x6	18	11	7
4-5x6	20	11	7
4-3x9	22	13	8
4-4x9	27	14	9
4-5x9	30	15	10
4-3x12	30	16	10
4-4x12	36	18	11
4-5x12	41	19	12
4-3x18	45	22	14
4-4x18	55	25	16
4-5x18	62	27	17
5-3x12	43	21	13
5-4x12	52	23	14
5-5x12	59	24	16
5-6x12	62	26	17
5-3x18	65	28	18
5-4x18	79	31	20
5-5x18	89	33	21
5-6x18	94	36	23
8-3x12	67	29	18
8-4x12	81	31	20
8-5x12	91	33	21
8-6x12	96	35	22
8-3x18	91	39	25
8-4x18	110	41	26
8-5x18	137	44	28
8-6x18	146	47	30

eco-LRWB Heat Loss Data

LRWB Model	Standard Unit (kW)	Unit with Hood (kW)	With Hood & Insulation (kW)
3-2x6	10	8	6
3-3x6	13	11	7
3-4x6	16	11	7
3-5x6	18	12	8
5-2x6	15	13	8
5-3x6	21	13	9
5-4x6	25	14	9
5-5x6	29	16	10
5-3x9	32	17	11
5-4x9	39	19	12
5-5x9	44	20	13
5-6x9	47	21	14
5-3x12	43	22	14
5-4x12	52	23	15
5-5x12	59	25	16
5-6x12	62	27	17
8-3x9	50	23	14
8-4x9	60	24	16
8-5x9	68	26	17
8-6x9	72	28	18
8-3x12	67	28	18
8-4x12	81	30	19
8-5x12	91	31	20
8-6x12	97	33	21

Discharge Hood Dimensions

eco-LSWE Tapered Discharge Hood Dimensions

Unit Footprint	H (mm)	L (mm)	W (mm)	Weight per Hood (kg)	# of Hoods
4' x 6'	838	1,826	537	73	1
4' x 9'	838	2,724	537	95	1
4' x 12'	838	3,645	537	127	1
4' x 18'	838	5,486	537	168	1
5' x 12'	1,003	3,645	740	163	1
5' x 18'	1,003	5,486	740	213	1
8P' x 12'	1,083	3,651	1,159	213	1
8P' x 18'	1,083	5,486	1,159	277	1
8P' x 24'	1,083	3,651	1,159	213	2
8P' x 36'	1,083	5,486	1,159	277	2
10' x 12'	1,280	3,648	1,476	281	1
10' x 18'	1,280	5,486	1,476	354	1
10' x 24'	1,280	3,648	1,476	281	2
10' x 36'	1,280	5,486	1,476	354	2

eco-LSWE Straight-Sided Discharge Hood Dimensions

Unit Footprint	H (mm)	L (mm)	W (mm)	Weight per Hood (kg)	# of Hoods
4' x 6'	762	1,826	1,156	73	1
4' x 9'	762	2,724	1,156	91	1
4' x 12'	762	3,645	1,156	118	1
4' x 18'	762	5,486	1,156	150	1
5' x 12'	762	3,645	1,575	127	1
5' x 18'	762	5,486	1,575	163	1
8P' x 12'	762	3,651	2,426	154	1
8P' x 18'	762	5,486	2,426	191	1
8P' x 24'	762	3,651	2,426	154	2
8P' x 36'	762	5,486	2,426	191	2
10' x 12'	762	3,648	3,026	168	1
10' x 18'	762	5,493	3,026	240	1
10' x 24'	762	3,648	3,026	168	2
10' x 36'	762	5,493	3,026	240	2

eco-LRWB Tapered Discharge Hood Dimensions

Coil Casing Footprint	H (mm)	L (mm)	W (mm)	Weight per Hood (kg)	# of Hoods
3' x 6'	622	1,826	483	54	1
5' x 6'	997	1,826	737	95	1
5' x 9'	997	2,724	737	118	1
5' x 12'	997	3,648	737	159	1
8' x 9'	1,080	2,724	1,080	172	1
8' x 12'	1,080	3,648	1,080	204	1

eco-LRWB Straight-Sided Discharge Hood Dimensions

Coil Casing Footprint	H (mm)	L (mm)	W (mm)	Weight per Hood (kg)	# of Hoods
3' x 6'	749	1,826	1,029	68	1
5' x 6'	749	1,826	1,540	77	1
5' x 9'	749	2,724	1,540	95	1
5' x 12'	749	3,648	1,540	118	1
8' x 9'	749	2,724	2,388	113	1
8' x 12'	749	3,648	2,388	132	1

Steel Support

Steel Support

The recommended support for EVAPCO Closed Circuit Coolers is structural "I" beams located under the outer flanges and running the entire length of the unit. Mounting holes 19 mm in diameter are located in the bottom channels of the pan section to provide for bolting to the structural steel. (Refer to certified drawings from the factory for bolt hole locations.)

Beams should be level to within 1/360 of unit length, not to exceed 13 mm before setting the unit in place. Do not level the unit by shimming between it and the "I" beams as this will not provide proper longitudinal support.

eco-LRWB Dimensions

Coil Casing Footprint	A1 (Unit Only) (mm)	A2 (Unit with Intake Atten.) (mm)	B (mm)
3' x 6'	3,096	4,207	1,029
5' x 6'	3,731	4,842	1,540
5' x 9'	4,629	5,740	1,540
5' x 12'	5,553	6,664	1,540
8' x 9'	4,629	5,740	2,388
8' x 12'	5,553	6,664	2,388

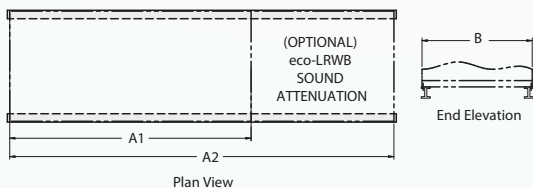

eco-LSWE Dimensions

Coil Casing Footprint	Compact		Base	Extended
	A	B1	B2	B2
4 x 6	1826	1235	2378	3048
4 x 9	2724	1235	2378	3048
4 x 12	3645	1235	2378	3048
4 x 18	5486	1235	2378	3048
5 x 12	3645	1651	2794	3453
5 x 18	5483	1651	2794	3453
8 x 12	3651	2388	3531	4188
8 x 18	5486	2388	3531	4188
8 x 24	7341	2388	3531	4188
8 x 36	11011	2388	3531	4188
10 x 12	3651	2991	4134	4791
10 x 18	5493	2991	4134	4791
10 x 24	7344	2991	4134	4791
10 x 36	11027	2991	4134	4791

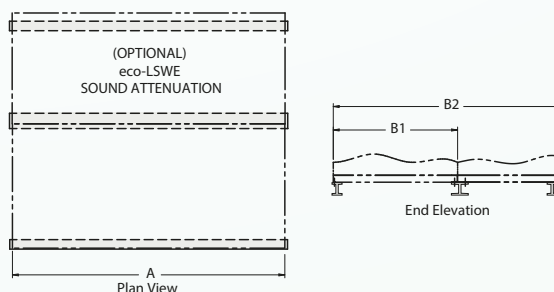

Optional Equipment

Electric Water Level Control

Closed Circuit Coolers may be ordered with an electric water level control in lieu of the standard mechanical float and make-up assembly. This package provides accurate control of water levels and does not require field adjustment.



Bottom Screens

Protective inlet screens are provided on the sides and/or end of the unit's air intake. Screens are not provided below the fan section since most units are mounted on the roof or at ground level. It is recommended that bottom screens be added to the unit when it will be elevated. These screens can be provided by the factory at an additional cost or added by the installing contractor.

Solid Bottom Panels for Ducted Installations

When centrifugal fan units are installed indoors and intake air is ducted to the unit, a solid bottom panel is required to completely enclose the fan section and prevent the unit from drawing air from the room into the fan intakes. When this option is ordered, air inlet screens are omitted and the next larger size fan motor must be used to overcome the additional static pressure.

Specific Design Features

eco-LRWB Reduced Height and Maintenance Accessibility

The eco-LRWB has been designed to satisfy installation requirements where height limits must be observed. The lower profile design of the eco-LRWB does not, however, sacrifice maintenance accessibility for reduced height. Its unique casing design allows the water distribution system, cold water basin, fan section and other unit components to be easily maintained.

Small, light-weight sections of the drift eliminators can be easily removed to access the water distribution system. A large circular access door is located on the side of the cold water basin to allow adjustment of the float assembly, removal of the stainless steel strainers and cleaning of the basin. The fan motor and drive system are located at one end of the unit and are completely accessible by removing the inlet screens. Routine bearing lubrication and belt tensioning can be performed from the exterior of the unit without removing the inlet screens.

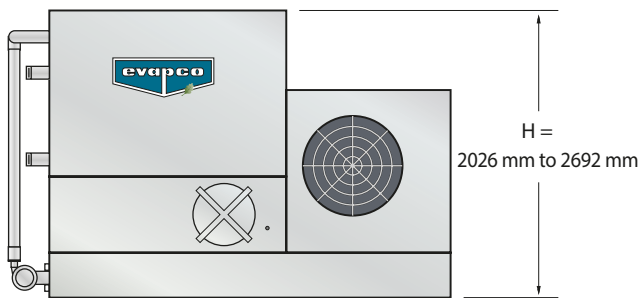

Low Installed Costs

The compact, unitary design of the eco-LRWB closed circuit cooler allows it to be shipped completely assembled. This results in lower transportation costs and no assembly requirements at the job site. Note: Options such as sound attenuation and discharge hoods will require additional lifts and some minor assembly.

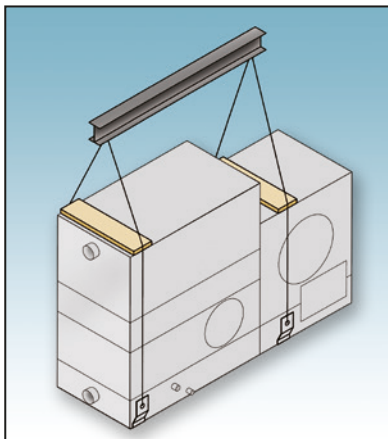

Transport of a Pre-Assembled Unit

Since the eco-LRWB ships fully assembled, it is ideal for truck-mounted applications, for remote sites or temporary installations.

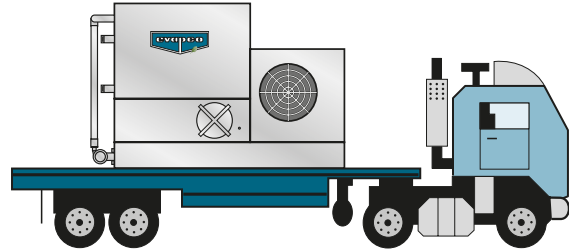

Stainless Steel Cold Water Basin—Standard

The eco-LRWB is standard with a stainless steel cold water basin. Optional upgrades to stainless steel water touch basins, stainless steel water touch units and all stainless steel construction are also available on the eco-LRWB.



Integral Fan Enclosure for Lower Sound

The eco-LRWB comes standard with an integral fan enclosure that reduces sound levels by 2 dB. This 3-sided enclosure also protects the fan and drive system for longer equipment life.

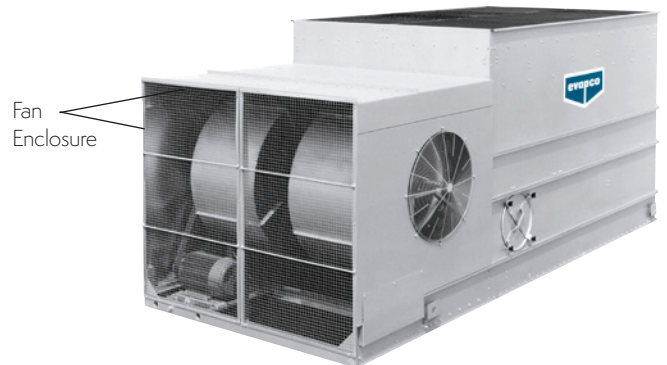

General Information

Design

EVAPCO closed circuit coolers are of heavy-duty construction and designed for long trouble-free operation. Proper equipment selection, installation and maintenance is, however, necessary to ensure full unit performance. Some of the major considerations in the application of a cooler are presented below. For additional information, contact the factory.

Air Circulation

It is important that proper air circulation be provided. The best location is on an unobstructed roof top or on ground level away from walls and other barriers. Those closed circuit coolers located in wells, enclosures or adjacent to high walls must be properly located to avoid the problems associated with recirculation.

Recirculation raises the wet bulb temperature of the entering air causing the water temperature to rise above the design. For these cases, the discharge of the unit should be located at a height even with the adjacent wall, thereby reducing the chance of recirculation. For additional information, see the EVAPCO equipment layout manual. Good engineering practice dictates that the closed circuit cooler discharge air not be directed or located close to or in the vicinity of building air intakes.

Piping

Cooler piping should be designed and installed in accordance with generally accepted engineering practices. The piping layout should be symmetrical on multiple unit systems, and sized for a reasonably low water velocity and pressure drop.

The standard closed circuit cooler is recommended only on a closed, pressurized system. The piping system should include an expansion tank to allow for fluid expansion and purging air from the system.

Note: closed circuit coolers should never be used on an open type system. An open type system with a cooler may result in premature coil failure.

The piping system should be designed to permit complete drainage of the heat exchanger coil. This will require a vacuum breaker or air vent to be installed at the high point and a drain valve installed at the low point of the piping system. Both must be adequately sized.

All piping should be securely anchored by properly designed hangers and supports. No external loads should be placed upon the cooler connections, nor should any of the pipe supports be anchored to the cooler framework.

Recirculating Water Quality

Proper water treatment is an essential part of the maintenance required for evaporative cooling equipment.

A well designed and consistently implemented water treatment program will help to ensure efficient system operation while maximizing the equipment's service life. **If EVAPCO factory mounted water systems are not utilized**, a qualified water treatment company should design a site specific water treatment protocol based on equipment (including all metallurgies in the cooling system), location, makeup water quality, and usage.

Bleed off

Evaporative cooling equipment requires a bleed or blow-down line, located on the discharge side of the recirculating pump, to remove concentrated (cycled up) water from the system. EVAPCO recommends an automated conductivity controller to maximize the water efficiency of your system.

If EVAPCO factory mounted water systems are not utilized, based on recommendations from your water treatment company, the conductivity controller should open and close a motorized ball or solenoid valve to maintain the conductivity of the recirculating water. If a manual valve is used to control the rate of bleed it should be set to maintain the conductivity of the recirculating water during periods of peak load at the maximum level recommended by your water treatment company.

Water Treatment

The water treatment program prescribed for the given conditions must be compatible with the unit's materials of construction, including any galvanized components. The initial commissioning and passivation period is a critical time for maximizing the service life of galvanized equipment. EVAPCO recommends that the site specific water treatment protocol includes a passivation procedure which details water chemistry, any necessary chemical addition, and visual inspections during the first six (6) to twelve (12) weeks of operation. During this passivation period, recirculating water pH should be maintained above 7.0 and below 8.0 at all times. Batch feeding of chemicals is not recommended.

Control of Biological Contaminants

Evaporative cooling equipment should be inspected regularly to ensure good microbiological control. Inspections should include both monitoring of microbial populations via culturing techniques and visual inspections for evidence of biofouling. Poor microbiological control can result in loss of heat transfer efficiency, increase corrosion potential, and increase the risk of pathogens such as those that cause Legionnaires' disease. Your site specific water treatment protocol should include procedures for routine operation, startup after a shut-down period, and system lay-up, if applicable. If excessive microbiological contamination is detected, a more aggressive mechanical cleaning and/or water treatment program should be undertaken.

Models: eco-LSWE 4-2F6 to 4-5J9

Closed Circuit Coolers

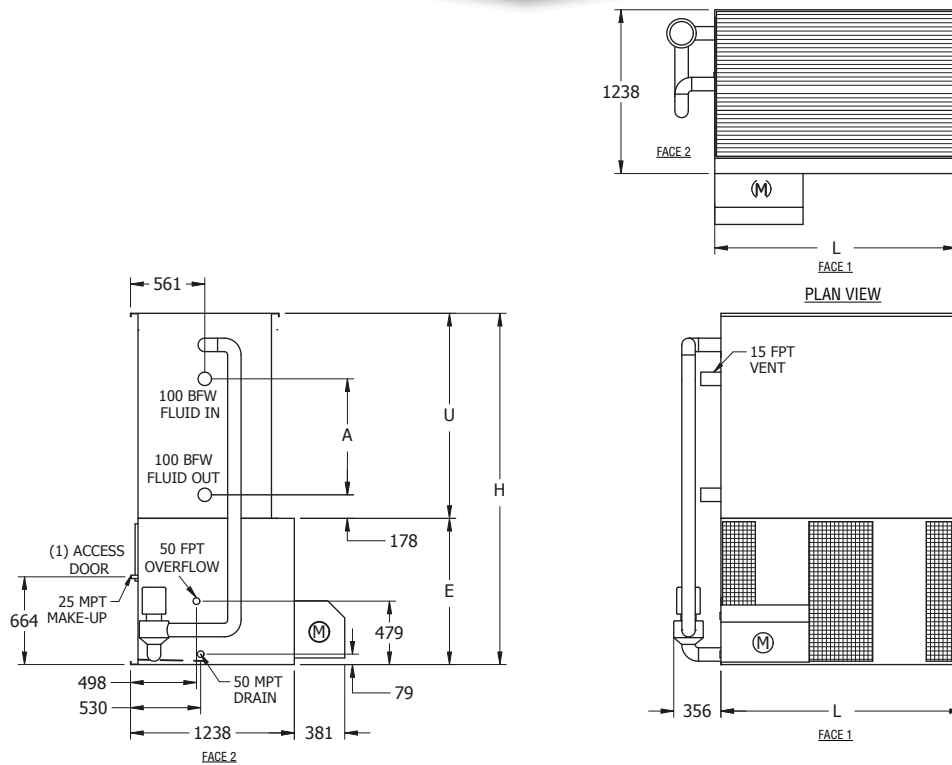

Model No. †	WEIGHTS (kg)			FANS		SPRAY PUMP	Coil Volume (Liters)	REMOTE SUMP Δ			DIMENSIONS ▲				
	Shipping	Heaviest Section*	Operating	kW	m³/s	kW		Liters Req'd**	Conn. Size	Operating Weight (kg)	Height H	Length L	Lower E	Upper U	Coil A
eco-LSWE 4-2F6	1.195	680	1.615	2,2	4,8	0,55	126	303	100	1.425	2.083	1.826	1.105	978	305
eco-LSWE 4-2G6	1.195	680	1.620	4	5,7	0,55	126	303	100	1.430	2.083	1.826	1.105	978	305
eco-LSWE 4-2H6	1.220	680	1.640	5,5	6,6	0,55	126	303	100	1.450	2.083	1.826	1.105	978	305
eco-LSWE 4-3F6	1.415	905	1.890	2,2	4,7	0,55	177	303	100	1.695	2.273	1.826	1.105	1.168	495
eco-LSWE 4-3G6	1.420	905	1.895	4	5,6	0,55	177	303	100	1.700	2.273	1.826	1.105	1.168	495
eco-LSWE 4-3H6	1.440	905	1.920	5,5	6,4	0,55	177	303	100	1.725	2.273	1.826	1.105	1.168	495
eco-LSWE 4-3I6	1.450	905	1.930	7,5	7,1	0,55	177	303	100	1.735	2.273	1.826	1.105	1.168	495
eco-LSWE 4-4F6	1.630	1.115	2.155	2,2	4,6	0,55	229	303	100	1.960	2.464	1.826	1.105	1.359	686
eco-LSWE 4-4G6	1.635	1.115	2.160	4	5,5	0,55	229	303	100	1.965	2.464	1.826	1.105	1.359	686
eco-LSWE 4-4H6	1.655	1.115	2.180	5,5	6,3	0,55	229	303	100	1.985	2.464	1.826	1.105	1.359	686
eco-LSWE 4-4I6	1.665	1.115	2.190	7,5	6,9	0,55	229	303	100	1.995	2.464	1.826	1.105	1.359	686
eco-LSWE 4-5G6	1.850	1.335	2.425	4	5,4	0,55	280	303	100	2.235	2.654	1.826	1.105	1.549	876
eco-LSWE 4-5H6	1.875	1.335	2.450	5,5	6,2	0,55	280	303	100	2.260	2.654	1.826	1.105	1.549	876
eco-LSWE 4-5I6	1.880	1.335	2.460	7,5	6,8	0,55	280	303	100	2.270	2.654	1.826	1.105	1.549	876
eco-LSWE 4-3G9	1.970	1.295	2.685	4	7,3	0,75	258	454	150	2.435	2.273	2.724	1.105	1.168	495
eco-LSWE 4-3H9	1.990	1.295	2.710	5,5	8,4	0,75	258	454	150	2.460	2.273	2.724	1.105	1.168	495
eco-LSWE 4-3I9	2.000	1.295	2.715	7,5	9,3	0,75	258	454	150	2.470	2.273	2.724	1.105	1.168	495
eco-LSWE 4-3J9	2.055	1.295	2.770	11	10,6	0,75	258	454	150	2.520	2.273	2.724	1.105	1.168	495
eco-LSWE 4-4H9	2.305	1.605	3.100	5,5	8,2	0,75	336	454	150	2.850	2.464	2.724	1.105	1.359	686
eco-LSWE 4-4I9	2.315	1.605	3.105	7,5	9,1	0,75	336	454	150	2.860	2.464	2.724	1.105	1.359	686
eco-LSWE 4-4J9	2.370	1.605	3.160	11	10,4	0,75	336	454	150	2.910	2.464	2.724	1.105	1.359	686
eco-LSWE 4-5H9	2.635	1.935	3.510	5,5	8,1	0,75	414	454	150	3.255	2.654	2.724	1.105	1.549	876
eco-LSWE 4-5I9	2.645	1.935	3.520	7,5	8,9	0,75	414	454	150	3.265	2.654	2.724	1.105	1.549	876
eco-LSWE 4-5J9	2.700	1.935	3.575	11	10,2	0,75	414	454	150	3.320	2.654	2.724	1.105	1.549	876

† Model Number will end in "-Z" for units with Series Flow piping configuration. Series Flow units may require additional coil connections and will require crossover piping. Model numbers will include "I" for units with Intake Attenuation, "D" for units with Discharge Attenuation, "F" for units with Full Sound Attenuation, "T" for units with a Tapered Discharge Hood, and "S" for units with an option that negates CTI Certification.

* Heaviest section is the coil section.

** Liters shown is water in suspension in unit and piping. Allow for additional water in bottom of remote sump to cover pump suction and strainer during operation (305 mm would normally be sufficient).

Δ When a remote sump arrangement is selected, the spray pump, suction strainer and associated piping are omitted; the unit is provided with an oversized outlet to facilitate drainage to the remote sump.

▲ Unit dimensions and coil connections may vary slightly from catalog. See factory certified prints for dimensions, quantity of coil connections, and piping configuration. Coil connections are 100 mm bevel for weld (BFW), also available as options. Other connection types such as grooved for mechanical coupling or flanged are also available as options.

Models: eco-LSWE 4-3H12 to 4-5M18

Closed Circuit Coolers

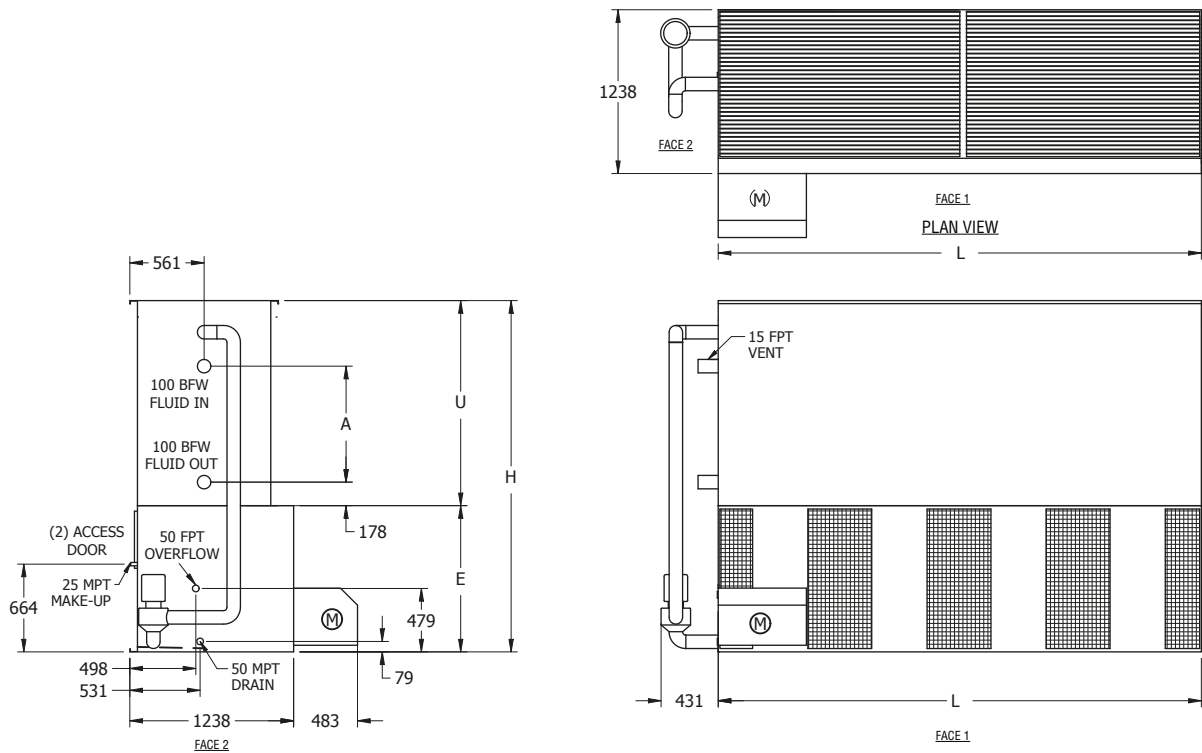

Model No. †	WEIGHTS (kg)			FANS		SPRAY PUMP	Coil Volume (Liters)	REMOTE SUMP Δ			DIMENSIONS ▲				
	Shipping	Heaviest Section*	Operating	kW	m ³ /s	kW		Liters Req'd**	Conn. Size	Operating Weight (kg)	Height H	Length L	Lower E	Upper U	Coil A
eco-LSWE 4-3H12	2.610	1.715	3.525	5,5	10,2	1,1	338	644	150	3.250	2.273	3.651	1.105	1.168	495
eco-LSWE 4-3I12	2.615	1.715	3.535	7,5	11,2	1,1	338	644	150	3.255	2.273	3.651	1.105	1.168	495
eco-LSWE 4-3J12	2.670	1.715	3.590	11	12,9	1,1	338	644	150	3.310	2.273	3.651	1.105	1.168	495
eco-LSWE 4-3K12	2.700	1.715	3.615	15	14,2	1,1	338	644	150	3.340	2.273	3.651	1.105	1.168	495
eco-LSWE 4-4I12	3.045	2.140	4.065	7,5	11	1,1	443	644	150	3.785	2.464	3.651	1.105	1.359	686
eco-LSWE 4-4J12	3.100	2.140	4.120	11	12,6	1,1	443	644	150	3.840	2.464	3.651	1.105	1.359	686
eco-LSWE 4-4K12	3.125	2.140	4.145	15	13,9	1,1	443	644	150	3.870	2.464	3.651	1.105	1.359	686
eco-LSWE 4-5I12	3.450	2.550	4.575	7,5	10,8	1,1	548	644	150	4.315	2.654	3.651	1.105	1.549	876
eco-LSWE 4-5J12	3.505	2.550	4.630	11	12,4	1,1	548	644	150	4.370	2.654	3.651	1.105	1.549	876
eco-LSWE 4-5K12	3.535	2.550	4.660	15	13,6	1,1	548	644	150	4.395	2.654	3.651	1.105	1.549	876
eco-LSWE 4-3I18	3.780	2.525	5.095	7,5	14,8	1,5	499	946	200	4.555	2.273	5.486	1.105	1.168	495
eco-LSWE 4-3J18	3.835	2.525	5.150	11	16,9	1,5	499	946	200	4.610	2.273	5.486	1.105	1.168	495
eco-LSWE 4-3K18	3.860	2.525	5.175	15	18,6	1,5	499	946	200	4.635	2.273	5.486	1.105	1.168	495
eco-LSWE 4-3L18	3.875	2.525	5.190	18,5	20	1,5	499	946	200	4.650	2.273	5.486	1.105	1.168	495
eco-LSWE 4-4J18	4.460	3.150	5.935	11	16,6	1,5	657	946	200	5.400	2.464	5.486	1.105	1.359	686
eco-LSWE 4-4K18	4.485	3.150	5.960	15	18,2	1,5	657	946	200	5.425	2.464	5.486	1.105	1.359	686
eco-LSWE 4-4L18	4.500	3.150	5.975	18,5	19,6	1,5	657	946	200	5.440	2.464	5.486	1.105	1.359	686
eco-LSWE 4-5J18	5.075	3.770	6.710	11	16,2	1,5	816	946	200	6.175	2.654	5.486	1.105	1.549	876
eco-LSWE 4-5K18	5.105	3.770	6.735	15	17,9	1,5	816	946	200	6.200	2.654	5.486	1.105	1.549	876
eco-LSWE 4-5L18	5.115	3.770	6.750	18,5	19,2	1,5	816	946	200	6.215	2.654	5.486	1.105	1.549	876
eco-LSWE 4-5M18	5.140	3.770	6.770	22	20,4	1,5	816	946	200	6.235	2.654	5.486	1.105	1.549	876

† Model Number will end in "-Z" for units with Series Flow piping configuration. Series Flow units may require additional coil connections and will require crossover piping. Model numbers will include "I" for units with Intake Attenuation, "D" for units with Discharge Attenuation, "F" for units with Full Sound Attenuation, "T" for units with a Tapered Discharge Hood, and "S" for units with an option that negates CTI Certification.

* Heaviest section is the coil section.

** Liters shown is water in suspension in unit and piping. Allow for additional water in bottom of remote sump to cover pump suction and strainer during operation (305 mm would normally be sufficient).

Δ When a remote sump arrangement is selected, the spray pump, suction strainer and associated piping are omitted; the unit is provided with an oversized outlet to facilitate drainage to the remote sump.

▲ Unit dimensions and coil connections may vary slightly from catalog. See factory certified prints for dimensions, quantity of coil connections, and piping configuration. Coil connections are 100 mm bevel for weld (BFW), also available as options. Other connection types such as grooved for mechanical coupling or flanged are also available as options.

Models: eco-LSWE 5-3112 to 5-6M12

Closed Circuit Coolers

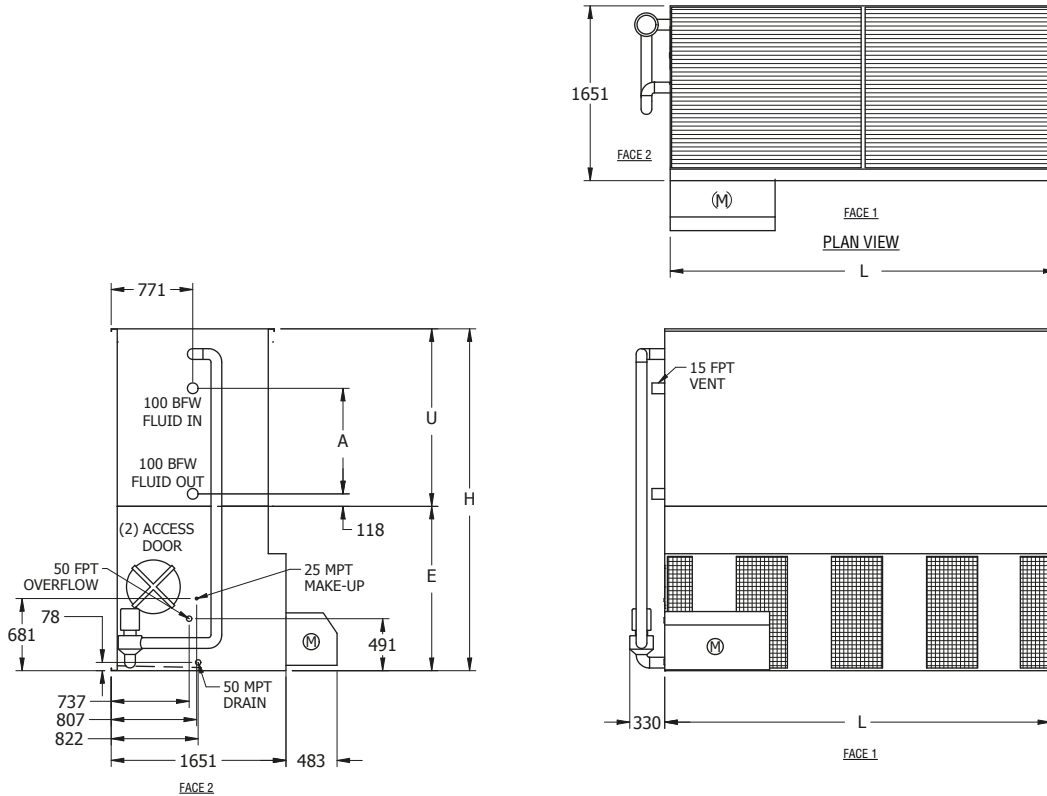

Model No. †	WEIGHTS (kg)			FANS		SPRAY PUMP	Coil Volume (Liters)	REMOTE SUMP Δ			DIMENSIONS ▲				
	Shipping	Heaviest Section*	Operating	kW	m³/s	kW		Liters Req'd**	Conn. Size	Operating Weight (kg)	Height H	Length L	Lower E	Upper U	Coil A
eco-LSWE 5-3112	3.465	2.300	5.045	7,5	14,1	1,5	479	871	150	4.265	2.797	3.645	1.553	1.245	565
eco-LSWE 5-3J12	3.520	2.300	5.100	11	16,2	1,5	479	871	150	4.320	2.797	3.645	1.553	1.245	565
eco-LSWE 5-3K12	3.545	2.300	5.125	15	17,8	1,5	479	871	150	4.345	2.797	3.645	1.553	1.245	565
eco-LSWE 5-3L12	3.560	2.300	5.140	18,5	19,2	1,5	479	871	150	4.360	2.797	3.645	1.553	1.245	565
eco-LSWE 5-4112	4.065	2.900	5.790	7,5	13,8	1,5	629	871	150	5.025	3.013	3.645	1.553	1.461	781
eco-LSWE 5-4J12	4.120	2.900	5.845	11	15,8	1,5	629	871	150	5.080	3.013	3.645	1.553	1.461	781
eco-LSWE 5-4K12	4.145	2.900	5.875	15	17,4	1,5	629	871	150	5.105	3.013	3.645	1.553	1.461	781
eco-LSWE 5-4L12	4.160	2.900	5.890	18,5	18,8	1,5	629	871	150	5.120	3.013	3.645	1.553	1.461	781
eco-LSWE 5-5J12	4.730	3.510	6.610	11	15,5	1,5	778	871	150	5.845	3.229	3.645	1.553	1.676	997
eco-LSWE 5-5K12	4.760	3.510	6.635	15	17,1	1,5	778	871	150	5.875	3.229	3.645	1.553	1.676	997
eco-LSWE 5-5L12	4.770	3.510	6.650	18,5	18,4	1,5	778	871	150	5.890	3.229	3.645	1.553	1.676	997
eco-LSWE 5-6J12	5.335	4.115	7.360	11	15,2	1,5	928	871	150	6.605	3.445	3.645	1.553	1.892	1.213
eco-LSWE 5-6K12	5.360	4.115	7.390	15	16,7	1,5	928	871	150	6.630	3.445	3.645	1.553	1.892	1.213
eco-LSWE 5-6L12	5.375	4.115	7.405	18,5	18	1,5	928	871	150	6.645	3.445	3.645	1.553	1.892	1.213
eco-LSWE 5-6M12	5.400	4.115	7.425	22	19,2	1,5	928	871	150	6.670	3.445	3.645	1.553	1.892	1.213

† Model Number will end in "-Z" for units with Series Flow piping configuration. Series Flow units may require additional coil connections and will require crossover piping. Model numbers will include "I" for units with Intake Attenuation, "D" for units with Discharge Attenuation, "F" for units with Full Sound Attenuation, "T" for units with a Tapered Discharge Hood, and "S" for units with an option that negates CTI Certification.

* Heaviest section is the coil section.

** Liters shown is water in suspension in unit and piping. Allow for additional water in bottom of remote sump to cover pump suction and strainer during operation (305 mm would normally be sufficient).

Δ When a remote sump arrangement is selected, the spray pump, suction strainer and associated piping are omitted; the unit is provided with an oversized outlet to facilitate drainage to the remote sump.

▲ Unit dimensions and coil connections may vary slightly from catalog. See factory certified prints for dimensions, quantity of coil connections, and piping configuration. Coil connections are 100 mm bevel for weld (BFW), also available as options. Other connection types such as grooved for mechanical coupling or flanged are also available as options.

Models: eco-LSWE 5-3J18 to 5-6N18

Closed Circuit Coolers

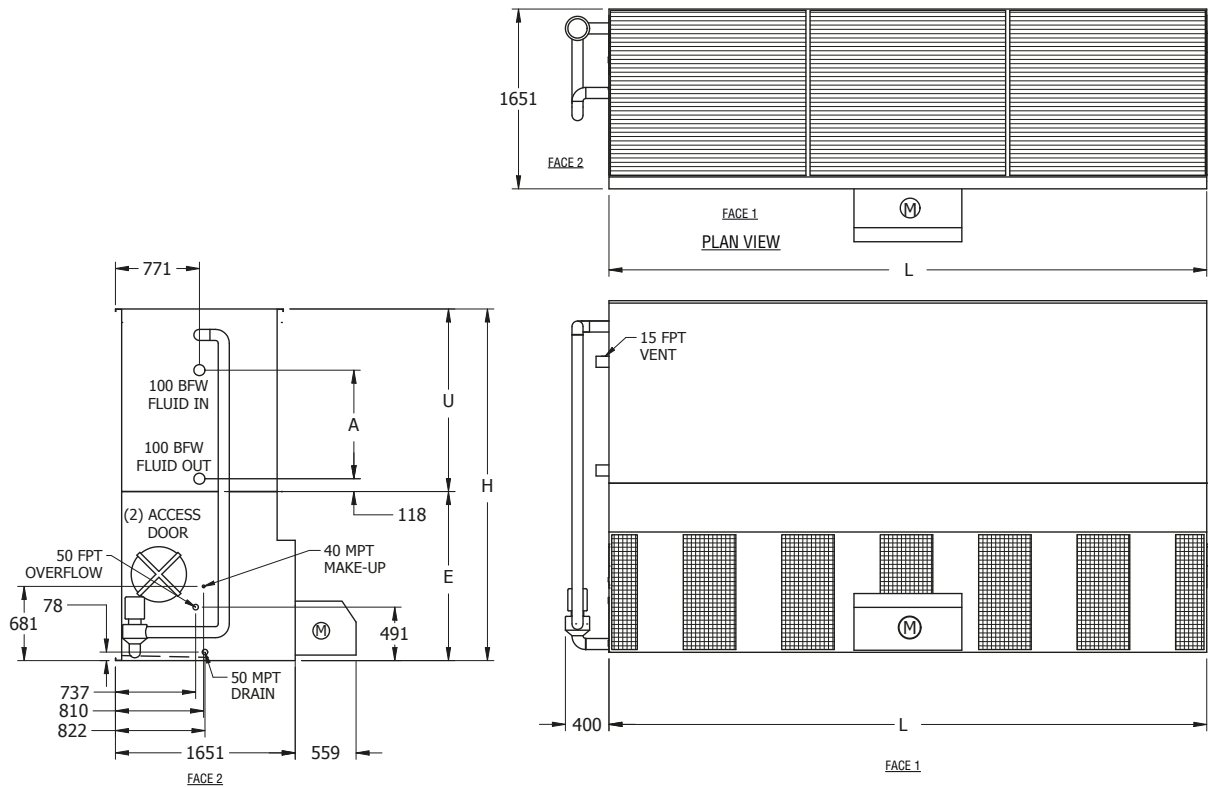

Note: The number of coil connections may increase based on design flow rate.

Model No. †	WEIGHTS (kg)			FANS		SPRAY PUMP	Coil Volume (Liters)	REMOTE SUMP Δ			DIMENSIONS ▲				
	Shipping	Heaviest Section*	Operating	kW	m ³ /s	kW		Liters Req'd**	Conn. Size	Operating Weight (kg)	Height H	Length L	Lower E	Upper U	Coil A
eco-LSWE 5-3J18	5.205	3.445	7.465	11	21,2	2,2	708	1.287	200	6.115	2.797	5.483	1.553	1.245	565
eco-LSWE 5-3K18	5.230	3.445	7.495	15	23,4	2,2	708	1.287	200	6.140	2.797	5.483	1.553	1.245	565
eco-LSWE 5-3L18	5.245	3.445	7.505	18,5	25,2	2,2	708	1.287	200	6.155	2.797	5.483	1.553	1.245	565
eco-LSWE 5-3M18	5.265	3.445	7.530	22	26,7	2,2	708	1.287	200	6.180	2.797	5.483	1.553	1.245	565
eco-LSWE 5-4K18	6.130	4.340	8.615	15	22,9	2,2	934	1.287	200	7.260	3.013	5.483	1.553	1.461	781
eco-LSWE 5-4L18	6.140	4.340	8.625	18,5	24,7	2,2	934	1.287	200	7.275	3.013	5.483	1.553	1.461	781
eco-LSWE 5-4M18	6.165	4.340	8.650	22	26,2	2,2	934	1.287	200	7.300	3.013	5.483	1.553	1.461	781
eco-LSWE 5-4N18	6.235	4.340	8.725	30	28,8	2,2	934	1.287	200	7.370	3.013	5.483	1.553	1.461	781
eco-LSWE 5-5K18	7.060	5.270	9.770	15	22,4	2,2	1.160	1.287	200	8.430	3.229	5.483	1.553	1.676	997
eco-LSWE 5-5L18	7.070	5.270	9.785	18,5	24,2	2,2	1.160	1.287	200	8.440	3.229	5.483	1.553	1.676	997
eco-LSWE 5-5M18	7.095	5.270	9.805	22	25,7	2,2	1.160	1.287	200	8.465	3.229	5.483	1.553	1.676	997
eco-LSWE 5-5N18	7.165	5.270	9.880	30	28,3	2,2	1.160	1.287	200	8.535	3.229	5.483	1.553	1.676	997
eco-LSWE 5-6L18	7.980	6.180	10.920	18,5	23,7	2,2	1.386	1.287	200	9.590	3.445	5.483	1.553	1.892	1.213
eco-LSWE 5-6M18	8.000	6.180	10.940	22	25,2	2,2	1.386	1.287	200	9.610	3.445	5.483	1.553	1.892	1.213
eco-LSWE 5-6N18	8.075	6.180	11.015	30	27,7	2,2	1.386	1.287	200	9.685	3.445	5.483	1.553	1.892	1.213

† Model Number will end in "-Z" for units with Series Flow piping configuration. Series Flow units may require additional coil connections and will require crossover piping. Model numbers will include "I" for units with Intake Attenuation, "D" for units with Discharge Attenuation, "F" for units with Full Sound Attenuation, "T" for units with a Tapered Discharge Hood, and "S" for units with an option that negates CTI Certification.

* Heaviest section is the coil section.

** Liters shown is water in suspension in unit and piping. Allow for additional water in bottom of remote sump to cover pump suction and strainer during operation (305 mm would normally be sufficient).

Δ When a remote sump arrangement is selected, the spray pump, suction strainer and associated piping are omitted; the unit is provided with an oversized outlet to facilitate drainage to the remote sump.

▲ Unit dimensions and coil connections may vary slightly from catalog. See factory certified prints for dimensions, quantity of coil connections, and piping configuration. Coil connections are 100 mm bevel for weld (BFW), also available as options. Other connection types such as grooved for mechanical coupling or flanged are also available as options.

Models: eco-LSWE 8P-3K12 to 8P-6O12

Closed Circuit Coolers

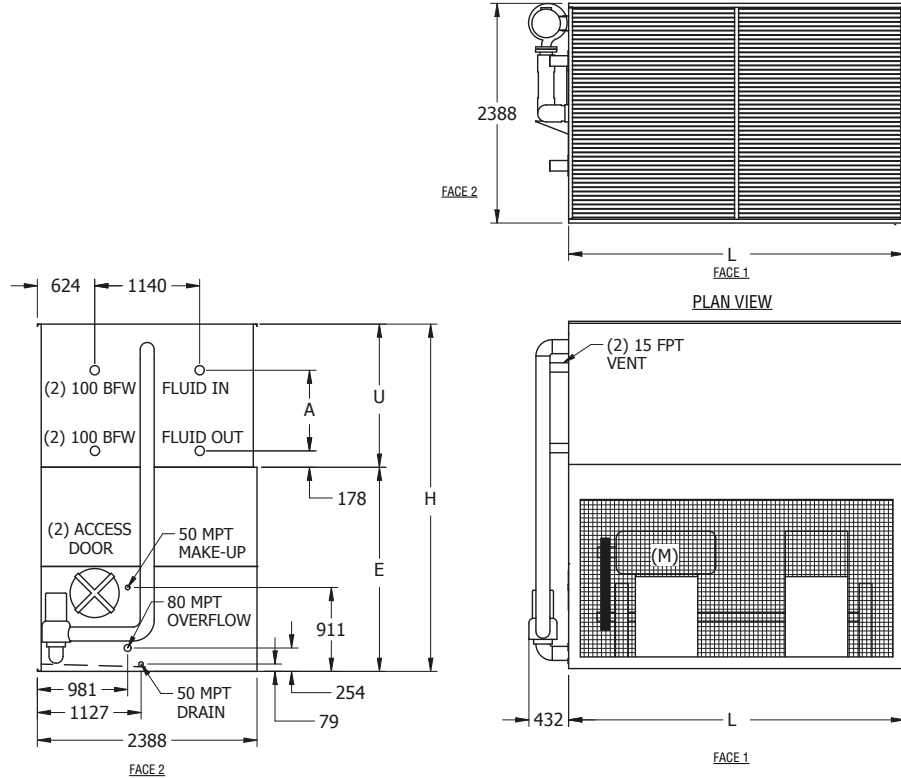

Model No. †	WEIGHTS (kg)			FANS		SPRAY PUMP	Coil Volume (Liters)	REMOTE SUMP Δ			DIMENSIONS ▲				
	Shipping	Heaviest Section*	Operating	kW	m³/s	kW		Liters Req'd**	Conn. Size	Operating Weight (kg)	Height H	Length L	Lower E	Upper U	Coil A
eco-LSWE 8P-3K12	5.170	3.450	7.455	15	22,9	4	756	1.363	250	6.565	3.394	3.651	2.219	1.175	495
eco-LSWE 8P-3L12	5.185	3.450	7.470	18,5	24,7	4	756	1.363	250	6.575	3.394	3.651	2.219	1.175	495
eco-LSWE 8P-3M12	5.205	3.450	7.495	22	26,3	4	756	1.363	250	6.600	3.394	3.651	2.219	1.175	495
eco-LSWE 8P-3N12	5.280	3.450	7.565	30	28,9	4	756	1.363	250	6.670	3.394	3.651	2.219	1.175	495
eco-LSWE 8P-4L12	6.100	4.370	8.625	18,5	24,2	4	991	1.363	250	7.780	3.585	3.651	2.219	1.365	686
eco-LSWE 8P-4M12	6.125	4.370	8.645	22	25,8	4	991	1.363	250	7.800	3.585	3.651	2.219	1.365	686
eco-LSWE 8P-4N12	6.195	4.370	8.720	30	28,3	4	991	1.363	250	7.875	3.585	3.651	2.219	1.365	686
eco-LSWE 8P-4O12	6.200	4.370	8.725	37	30,5	4	991	1.363	250	7.880	3.585	3.651	2.219	1.365	686
eco-LSWE 8P-5M12	7.015	5.255	9.770	22	25,2	4	1.227	1.363	250	8.975	3.775	3.651	2.219	1.556	876
eco-LSWE 8P-5N12	7.085	5.255	9.845	30	27,8	4	1.227	1.363	250	9.050	3.775	3.651	2.219	1.556	876
eco-LSWE 8P-5O12	7.090	5.255	9.845	37	29,9	4	1.227	1.363	250	9.055	3.775	3.651	2.219	1.556	876
eco-LSWE 8P-6M12	7.925	6.170	10.920	22	24,7	4	1.462	1.363	250	10.180	3.966	3.651	2.219	1.746	1.067
eco-LSWE 8P-6N12	7.995	6.170	10.990	30	27,2	4	1.462	1.363	250	10.250	3.966	3.651	2.219	1.746	1.067
eco-LSWE 8P-6O12	8.000	6.170	10.995	37	29,3	4	1.462	1.363	250	10.255	3.966	3.651	2.219	1.746	1.067

† Model Number will end in "-Z" for units with Series Flow piping configuration. Series Flow units may require additional coil connections and will require crossover piping. Model numbers will include "I" for units with Intake Attenuation, "D" for units with Discharge Attenuation, "F" for units with Full Sound Attenuation, "T" for units with a Tapered Discharge Hood, and "S" for units with an option that negates CTI Certification.

* Heaviest section is the coil section.

** Liters shown is water in suspension in unit and piping. Allow for additional water in bottom of remote sump to cover pump suction and strainer during operation (305 mm would normally be sufficient).

Δ When a remote sump arrangement is selected, the spray pump, suction strainer and associated piping are omitted; the unit is provided with an oversized outlet to facilitate drainage to the remote sump.

▲ Unit dimensions and coil connections may vary slightly from catalog. See factory certified prints for dimensions, quantity of coil connections, and piping configuration. Coil connections are 100 mm bevel for weld (BFW), also available as options. Other connection types such as grooved for mechanical coupling or flanged are also available as options.

Models: eco-LSWE 8P-3M18 to 8P-6P18

Closed Circuit Coolers

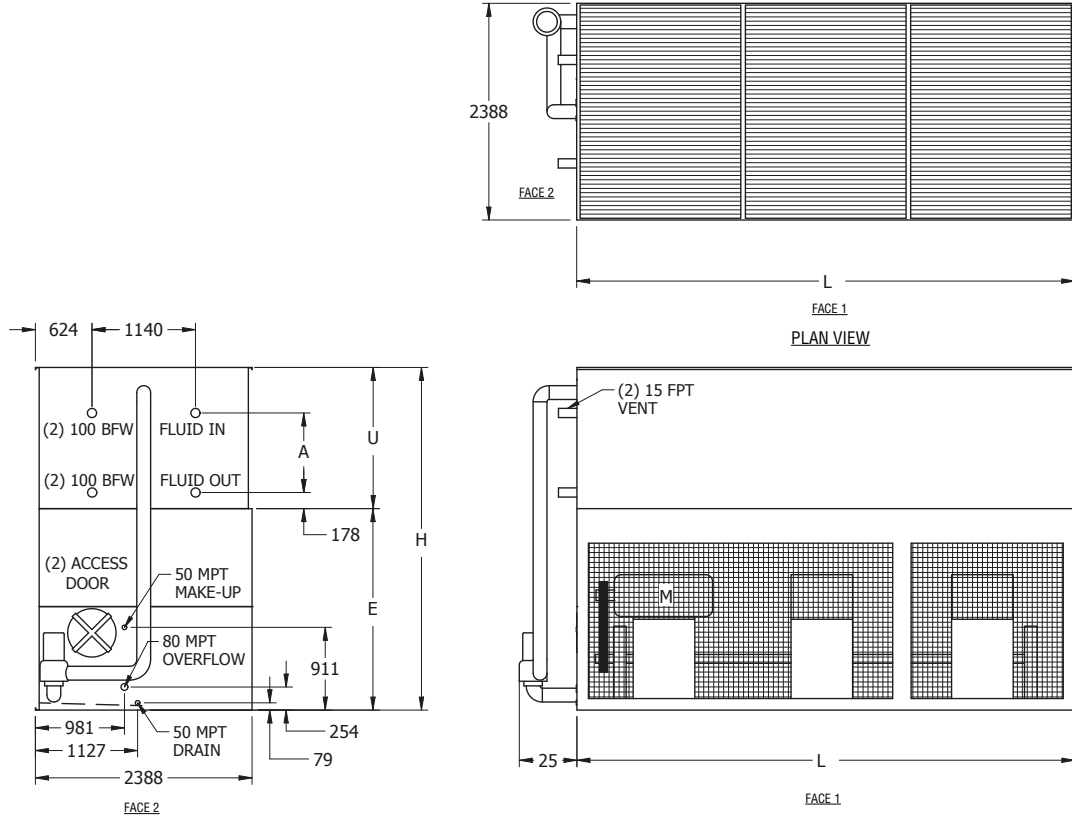

Note: The number of coil connections may increase based on design flow rate.

Model No. †	WEIGHTS (kg)			FANS		SPRAY PUMP	Coil Volume (Liters)	REMOTE SUMP Δ			DIMENSIONS ▲				
	Shipping	Heaviest Section**	Operating	kW	m³/s	kW		Liters Req'd**	Conn. Size	Operating Weight (kg)	Height H	Length L	Lower E	Upper U	Coil A
eco-LSWE 8P-3M18	7.495	5.115	10.940	22	34,3	5,5	1.117	2.006	300	9.625	3.394	5.486	2.219	1.175	495
eco-LSWE 8P-3N18	7.565	5.115	11.015	30	37,8	5,5	1.117	2.006	300	9.700	3.394	5.486	2.219	1.175	495
eco-LSWE 8P-3O18	7.570	5.115	11.020	37	40,7	5,5	1.117	2.006	300	9.700	3.394	5.486	2.219	1.175	495
eco-LSWE 8P-3P18	7.660	5.115	11.110	45	43,3	5,5	1.117	2.006	300	9.795	3.394	5.486	2.219	1.175	495
eco-LSWE 8P-4M18	8.870	6.490	12.670	22	33,7	5,5	1.472	2.006	300	11.435	3.585	5.486	2.219	1.365	686
eco-LSWE 8P-4N18	8.940	6.490	12.740	30	37,1	5,5	1.472	2.006	300	11.510	3.585	5.486	2.219	1.365	686
eco-LSWE 8P-4O18	8.945	6.490	12.745	37	39,9	5,5	1.472	2.006	300	11.510	3.585	5.486	2.219	1.365	686
eco-LSWE 8P-4P18	9.035	6.490	12.835	45	42,4	5,5	1.472	2.006	300	11.605	3.585	5.486	2.219	1.365	686
eco-LSWE 8P-5N18	10.265	7.815	14.420	30	36,3	5,5	1.827	2.006	300	13.265	3.775	5.486	2.219	1.556	876
eco-LSWE 8P-5O18	10.270	7.815	14.425	37	39,1	5,5	1.827	2.006	300	13.270	3.775	5.486	2.219	1.556	876
eco-LSWE 8P-5P18	10.360	7.815	14.515	45	41,6	5,5	1.827	2.006	300	13.360	3.775	5.486	2.219	1.556	876
eco-LSWE 8P-6N18	11.655	9.210	16.170	30	35,6	5,5	2.183	2.006	300	15.085	3.966	5.486	2.219	1.746	1.067
eco-LSWE 8P-6O18	11.660	9.210	16.175	37	38,3	5,5	2.183	2.006	300	15.090	3.966	5.486	2.219	1.746	1.067
eco-LSWE 8P-6P18	11.755	9.210	16.265	45	40,7	5,5	2.183	2.006	300	15.180	3.966	5.486	2.219	1.746	1.067

† Model Number will end in "-Z" for units with Series Flow piping configuration. Series Flow units may require additional coil connections and will require crossover piping. Model numbers will include "I" for units with Intake Attenuation, "D" for units with Discharge Attenuation, "F" for units with Full Sound Attenuation, "T" for units with a Tapered Discharge Hood, and "S" for units with an option that negates CTI Certification.

* Heaviest section is the coil section.

** Liters shown is water in suspension in unit and piping. Allow for additional water in bottom of remote sump to cover pump suction and strainer during operation (305 mm would normally be sufficient).

Δ When a remote sump arrangement is selected, the spray pump, suction strainer and associated piping are omitted; the unit is provided with an oversized outlet to facilitate drainage to the remote sump.

▲ Unit dimensions and coil connections may vary slightly from catalog. See factory certified prints for dimensions, quantity of coil connections, and piping configuration. Coil connections are 100 mm bevel for weld (BFW), also available as options. Other connection types such as grooved for mechanical coupling or flanged are also available as options.

Models: eco-LSWE 8P-3K24 to 8P-6O24

Closed Circuit Coolers

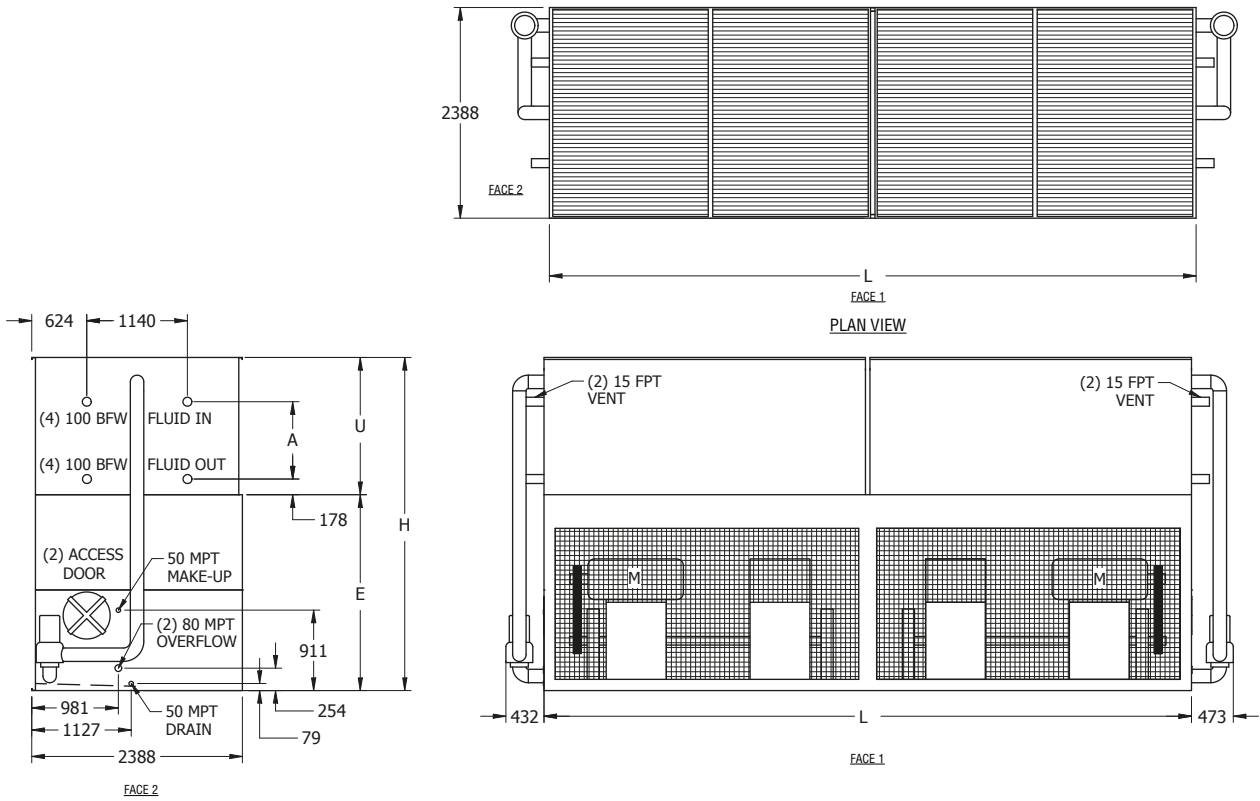

Model No. †	WEIGHTS (kg)			FANS		SPRAY PUMP	Coil Volume (Liters)	REMOTE SUMP Δ			DIMENSIONS ▲				
	Shipping	Heaviest Section**	Operating	kW	m ³ /s	kW		Liters Req'd**	Conn. Size	Operating Weight (kg)	Height H	Length L	Lower E	Upper U	Coil A
eco-LSWE 8P-3K24	10.035	3.450	14.635	(2) 15	45,9	(2) 4	1.512	2.725	(2) 250	13.215	3.394	7.341	2.219	1.175	495
eco-LSWE 8P-3L24	10.060	3.450	14.665	(2) 18.5	49,4	(2) 4	1.512	2.725	(2) 250	13.270	3.394	7.341	2.219	1.175	495
eco-LSWE 8P-3M24	10.105	3.450	14.710	(2) 22	52,5	(2) 4	1.512	2.725	(2) 250	13.360	3.394	7.341	2.219	1.175	495
eco-LSWE 8P-3N24	10.250	3.450	14.855	(2) 30	57,8	(2) 4	1.512	2.725	(2) 250	13.650	3.394	7.341	2.219	1.175	495
eco-LSWE 8P-4L24	11.885	4.365	16.960	(2) 18.5	48,5	(2) 4	1.983	2.725	(2) 250	15.680	3.585	7.341	2.219	1.365	686
eco-LSWE 8P-4M24	11.930	4.365	17.005	(2) 22	51,5	(2) 4	1.983	2.725	(2) 250	15.770	3.585	7.341	2.219	1.365	686
eco-LSWE 8P-4N24	12.075	4.365	17.150	(2) 30	56,7	(2) 4	1.983	2.725	(2) 250	16.060	3.585	7.341	2.219	1.365	686
eco-LSWE 8P-4O24	12.085	4.365	17.160	(2) 37	61,1	(2) 4	1.983	2.725	(2) 250	16.080	3.585	7.341	2.219	1.365	686
eco-LSWE 8P-5M24	13.715	5.255	19.265	(2) 22	50,5	(2) 4	2.453	2.725	(2) 250	18.125	3.775	7.341	2.219	1.556	876
eco-LSWE 8P-5N24	13.860	5.255	19.410	(2) 30	55,6	(2) 4	2.453	2.725	(2) 250	18.415	3.775	7.341	2.219	1.556	876
eco-LSWE 8P-5O24	13.870	5.255	19.420	(2) 37	59,8	(2) 4	2.453	2.725	(2) 250	18.435	3.775	7.341	2.219	1.556	876
eco-LSWE 8P-6M24	15.540	6.170	21.560	(2) 22	49,4	(2) 4	2.924	2.725	(2) 250	20.535	3.966	7.341	2.219	1.746	1.067
eco-LSWE 8P-6N24	15.685	6.170	21.705	(2) 30	54,4	(2) 4	2.924	2.725	(2) 250	20.825	3.966	7.341	2.219	1.746	1.067
eco-LSWE 8P-6O24	15.695	6.170	21.715	(2) 37	58,6	(2) 4	2.924	2.725	(2) 250	20.845	3.966	7.341	2.219	1.746	1.067

† Model Number will end in "-Z" for units with Series Flow piping configuration. Series Flow units may require additional coil connections and will require crossover piping. Model numbers will include "I" for units with Intake Attenuation, "D" for units with Discharge Attenuation, "F" for units with Full Sound Attenuation, "T" for units with a Tapered Discharge Hood, and "S" for units with an option that negates CTI Certification.

* Heaviest section is the coil section.

** Liters shown is water in suspension in unit and piping. Allow for additional water in bottom of remote sump to cover pump suction and strainer during operation (305 mm would normally be sufficient).

Δ When a remote sump arrangement is selected, the spray pump, suction strainer and associated piping are omitted; the unit is provided with an oversized outlet to facilitate drainage to the remote sump.

▲ Unit dimensions and coil connections may vary slightly from catalog. See factory certified prints for dimensions, quantity of coil connections, and piping configuration. Coil connections are 100 mm bevel for weld (BFW), also available as options. Other connection types such as grooved for mechanical coupling or flanged are also available as options.

Models: eco-LSWE 8P-3M36 to 8P-6P36

Closed Circuit Coolers

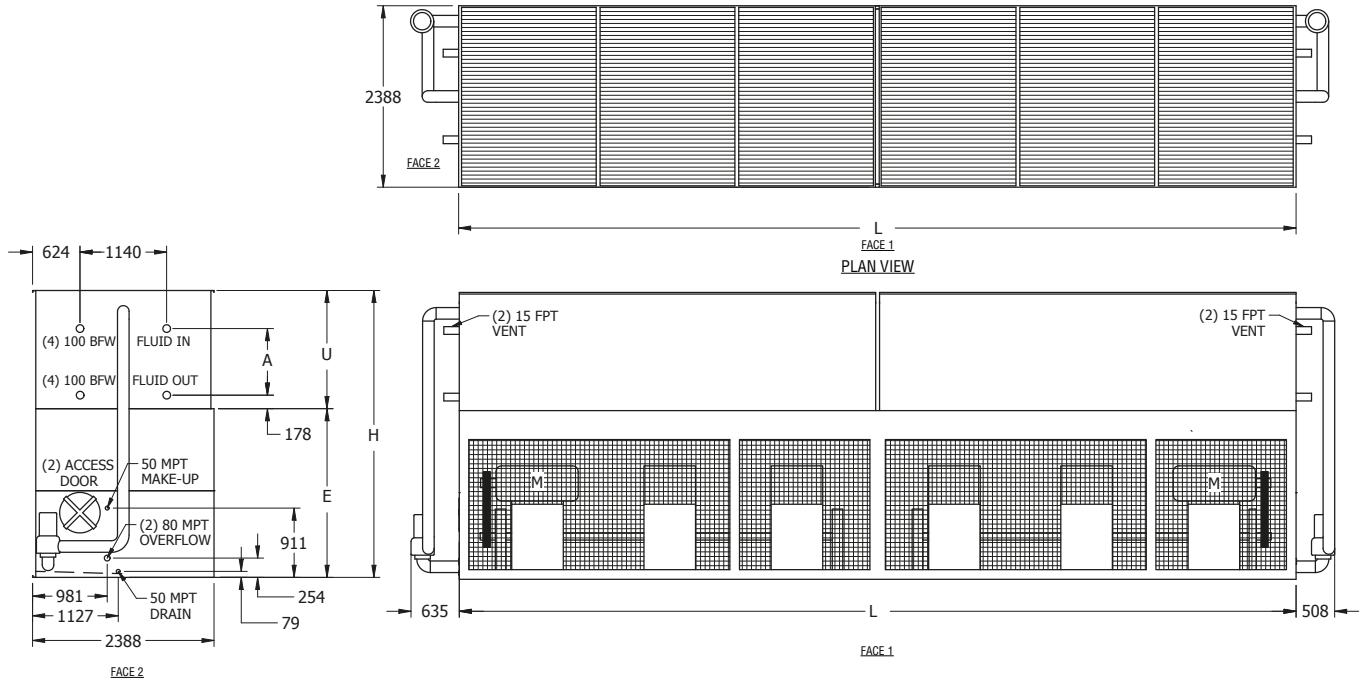

Note: The number of coil connections may increase based on design flow rate.

Model No. †	WEIGHTS (kg)			FANS		SPRAY PUMP	Coil Volume (Liters)	REMOTE SUMP Δ			DIMENSIONS ▲				
	Shipping	Heaviest Section*	Operat- ing	kW	m ³ /s	kW		Liters Req'd**	Conn. Size	Operating Weight (kg)	Height H	Length L	Lower E	Upper U	Coil A
eco-LSWE 8P-3M36	14.645	5.115	21.585	(2) 22	68,7	(2) 5,5	2.233	4.013	(2) 300	19.415	3.394	11.024	2.219	1.175	495
eco-LSWE 8P-3N36	14.790	5.115	21.730	(2) 30	75,6	(2) 5,5	2.233	4.013	(2) 300	19.705	3.394	11.024	2.219	1.175	495
eco-LSWE 8P-3O36	14.800	5.115	21.740	(2) 37	81,4	(2) 5,5	2.233	4.013	(2) 300	19.720	3.394	11.024	2.219	1.175	495
eco-LSWE 8P-3P36	14.980	5.115	21.920	(2) 45	86,5	(2) 5,5	2.233	4.013	(2) 300	20.085	3.394	11.024	2.219	1.175	495
eco-LSWE 8P-4M36	17.405	6.495	25.050	(2) 22	67,3	(2) 5,5	2.944	4.013	(2) 300	23.035	3.585	11.024	2.219	1.365	686
eco-LSWE 8P-4N36	17.550	6.495	25.195	(2) 30	74,1	(2) 5,5	2.944	4.013	(2) 300	23.325	3.585	11.024	2.219	1.365	686
eco-LSWE 8P-4O36	17.560	6.495	25.205	(2) 37	79,8	(2) 5,5	2.944	4.013	(2) 300	23.340	3.585	11.024	2.219	1.365	686
eco-LSWE 8P-4P36	17.740	6.495	25.390	(2) 45	84,8	(2) 5,5	2.944	4.013	(2) 300	23.705	3.585	11.024	2.219	1.365	686
eco-LSWE 8P-5N36	20.210	7.825	28.565	(2) 30	72,6	(2) 5,5	3.655	4.013	(2) 300	26.855	3.775	11.024	2.219	1.556	876
eco-LSWE 8P-5O36	20.215	7.825	28.570	(2) 37	78,2	(2) 5,5	3.655	4.013	(2) 300	26.875	3.775	11.024	2.219	1.556	876
eco-LSWE 8P-5P36	20.400	7.825	28.755	(2) 45	83,2	(2) 5,5	3.655	4.013	(2) 300	27.240	3.775	11.024	2.219	1.556	876
eco-LSWE 8P-6N36	22.975	9.210	32.045	(2) 30	71,2	(2) 5,5	4.366	4.013	(2) 300	30.485	3.966	11.024	2.219	1.746	1.067
eco-LSWE 8P-6O36	22.985	9.210	32.055	(2) 37	76,7	(2) 5,5	4.366	4.013	(2) 300	30.505	3.966	11.024	2.219	1.746	1.067
eco-LSWE 8P-6P36	23.165	9.210	32.235	(2) 45	81,5	(2) 5,5	4.366	4.013	(2) 300	30.865	3.966	11.024	2.219	1.746	1.067

† Model Number will end in "-Z" for units with Series Flow piping configuration. Series Flow units may require additional coil connections and will require crossover piping. Model numbers will include "I" for units with Intake Attenuation, "D" for units with Discharge Attenuation, "F" for units with Full Sound Attenuation, "T" for units with a Tapered Discharge Hood, and "S" for units with an option that negates CTI Certification.

* Heaviest section is the coil section.

** Liters shown is water in suspension in unit and piping. Allow for additional water in bottom of remote sump to cover pump suction and strainer during operation (305 mm would normally be sufficient).

Δ When a remote sump arrangement is selected, the spray pump, suction strainer and associated piping are omitted; the unit is provided with an oversized outlet to facilitate drainage to the remote sump.

▲ Unit dimensions and coil connections may vary slightly from catalog. See factory certified prints for dimensions, quantity of coil connections, and piping configuration. Coil connections are 100 mm bevel for weld (BFW), also available as options. Other connection types such as grooved for mechanical coupling or flanged are also available as options.

Models: eco-LSWE Models 10-3M12 to 10-6P12

Closed Circuit Coolers

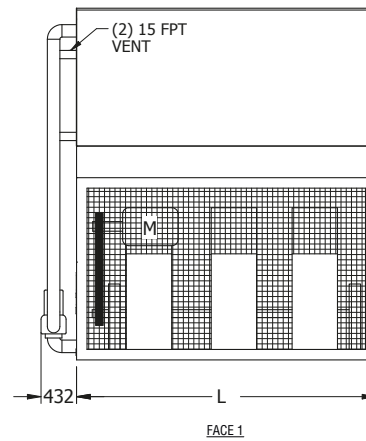
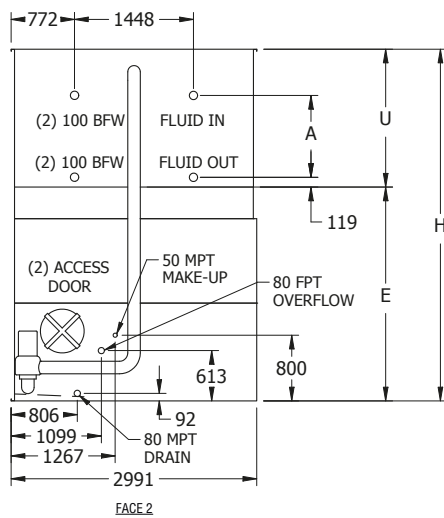
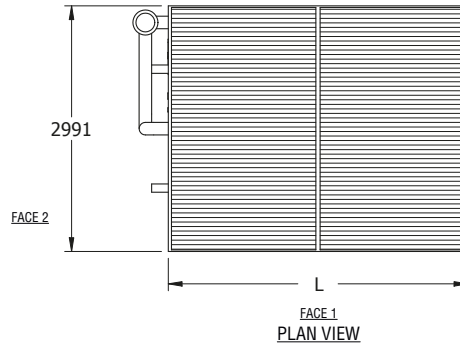

Model No. †	WEIGHTS (kg)			FANS		SPRAYPUMP	Coil Volume (Liters)	REMOTE SUMP Δ			DIMENSIONS ▲				
	Shipping	Heaviest Section*	Operating	kW	m³/s	kW		Liters Req'd**	Conn. Size	Operating Weight (kg)	Height H	Length L	Lower E	Upper U	Coil A
eco-LSWE 10-3M12	6.790	4.570	9.725	22	32,3	4	959	1.552	250	8.705	3.851	3.651	2.604	1.248	565
eco-LSWE 10-3N12	6.865	4.570	9.800	30	35,5	4	959	1.552	250	8.775	3.851	3.651	2.604	1.248	565
eco-LSWE 10-3O12	6.865	4.570	9.800	37	38,3	4	959	1.552	250	8.780	3.851	3.651	2.604	1.248	565
eco-LSWE 10-4M12	7.985	5.765	11.215	22	31,6	4	1.258	1.552	250	10.280	4.067	3.651	2.604	1.464	781
eco-LSWE 10-4N12	8.055	5.765	11.290	30	34,8	4	1.258	1.552	250	10.350	4.067	3.651	2.604	1.464	781
eco-LSWE 10-4O12	8.060	5.765	11.295	37	37,5	4	1.258	1.552	250	10.355	4.067	3.651	2.604	1.464	781
eco-LSWE 10-5M12	9.120	6.905	12.655	22	31	4	1.557	1.552	250	11.795	4.283	3.651	2.604	1.680	997
eco-LSWE 10-5N12	9.195	6.905	12.730	30	34,1	4	1.557	1.552	250	11.865	4.283	3.651	2.604	1.680	997
eco-LSWE 10-5O12	9.200	6.905	12.730	37	36,8	4	1.557	1.552	250	11.870	4.283	3.651	2.604	1.680	997
eco-LSWE 10-6M12	10.305	8.090	14.135	22	30,4	4	1.855	1.552	250	13.355	4.499	3.651	2.604	1.895	1.213
eco-LSWE 10-6N12	10.380	8.090	14.205	30	33,4	4	1.855	1.552	250	13.425	4.499	3.651	2.604	1.895	1.213
eco-LSWE 10-6O12	10.385	8.090	14.210	37	36	4	1.855	1.552	250	13.430	4.499	3.651	2.604	1.895	1.213
eco-LSWE 10-6P12	10.475	8.090	14.300	45	38,3	4	1.855	1.552	250	13.520	4.499	3.651	2.604	1.895	1.213

† Model Number will end in "-Z" for units with Series Flow piping configuration. Series Flow units may require additional coil connections and will require crossover piping. Model numbers will include "I" for units with Intake Attenuation, "D" for units with Discharge Attenuation, "F" for units with Full Sound Attenuation, "T" for units with a Tapered Discharge Hood, and "S" for units with an option that negates CTI Certification.

* Heaviest section is the coil section.

** Liters shown is water in suspension in unit and piping. Allow for additional water in bottom of remote sump to cover pump suction and strainer during operation (305 mm would normally be sufficient).

Δ When a remote sump arrangement is selected, the spray pump, suction strainer and associated piping are omitted; the unit is provided with an oversized outlet to facilitate drainage to the remote sump.

▲ Unit dimensions and coil connections may vary slightly from catalog. See factory certified prints for dimensions, quantity of coil connections, and piping configuration. Coil connections are 100 mm bevel for weld (BFW), also available as options. Other connection types such as grooved for mechanical coupling or flanged are also available as options.

Models: eco-LSWE 10-3K18 to 10-6N18

Closed Circuit Coolers

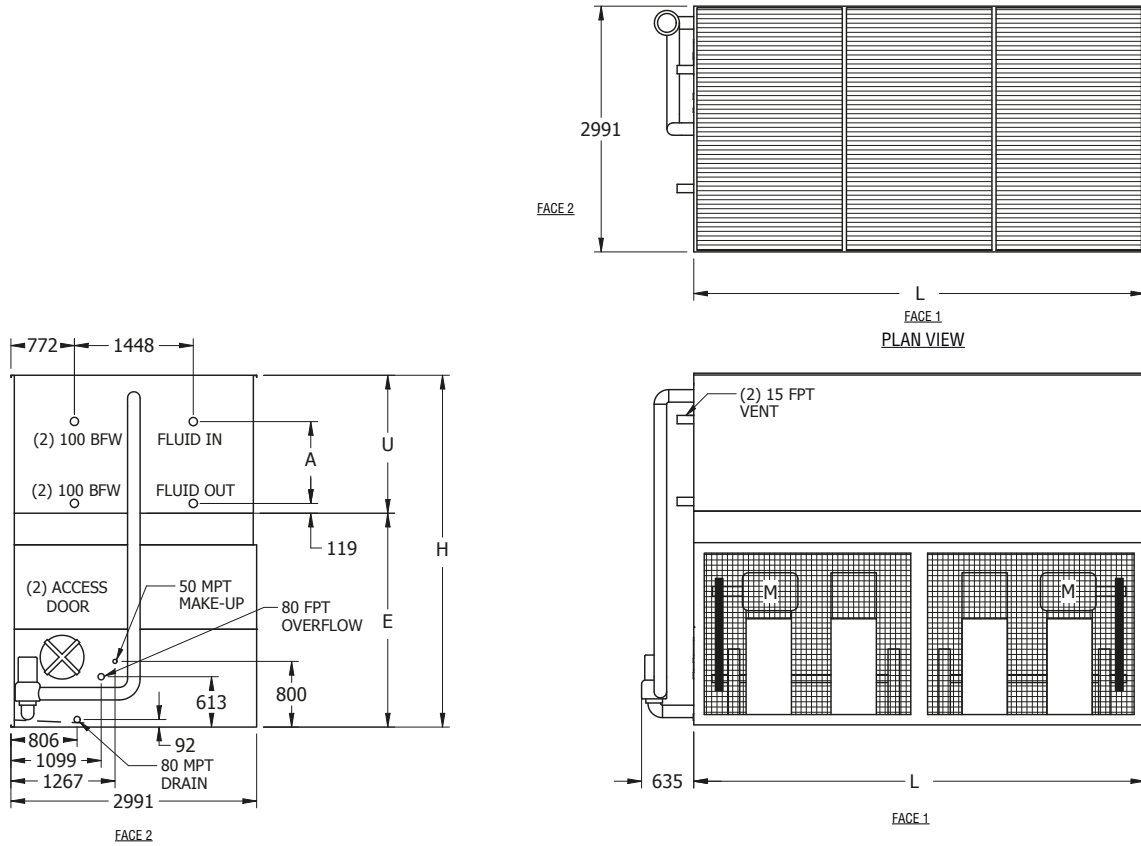

Note: The number of coil connections may increase based on design flow rate.

Model No. †	WEIGHTS (kg)			FANS		SPRAY PUMP	Coil Volume (Liters)	REMOTE SUMP Δ			DIMENSIONS ▲				
	Shipping	Heaviest Section*	Operating	kW	m³/s	kW		Liters Req'd**	Conn. Size	Operating Weight (kg)	Height H	Length L	Lower E	Upper U	Coil A
eco-LSWE 10-3K18	9.955	6.720	14.380	(2)15	46,6	5,5	1.417	2.271	300	12.785	3.851	5.493	2.604	1.248	565
eco-LSWE 10-3L18	9.985	6.720	14.405	(2)18.5	50,2	5,5	1.417	2.271	300	12.815	3.851	5.493	2.604	1.248	565
eco-LSWE 10-3M18	10.030	6.720	14.450	(2)22	53,4	5,5	1.417	2.271	300	12.860	3.851	5.493	2.604	1.248	565
eco-LSWE 10-3N18	10.175	6.720	14.595	(2)30	58,8	5,5	1.417	2.271	300	13.005	3.851	5.493	2.604	1.248	565
eco-LSWE 10-4L18	11.750	8.485	16.620	(2)18.5	49,2	5,5	1.868	2.271	300	15.125	4.067	5.493	2.604	1.464	781
eco-LSWE 10-4M18	11.795	8.485	16.665	(2)22	52,3	5,5	1.868	2.271	300	15.175	4.067	5.493	2.604	1.464	781
eco-LSWE 10-4N18	11.940	8.485	16.810	(2)30	57,6	5,5	1.868	2.271	300	15.320	4.067	5.493	2.604	1.464	781
eco-LSWE 10-5L18	13.460	10.195	18.785	(2)18.5	48,3	5,5	2.320	2.271	300	17.410	4.283	5.493	2.604	1.680	997
eco-LSWE 10-5M18	13.505	10.195	18.830	(2)22	51,3	5,5	2.320	2.271	300	17.455	4.283	5.493	2.604	1.680	997
eco-LSWE 10-5N18	13.650	10.195	18.975	(2)30	56,4	5,5	2.320	2.271	300	17.600	4.283	5.493	2.604	1.680	997
eco-LSWE 10-6L18	15.225	11.960	20.995	(2)18.5	47,3	5,5	2.771	2.271	300	19.735	4.499	5.493	2.604	1.895	1.213
eco-LSWE 10-6M18	15.270	11.960	21.040	(2)22	50,2	5,5	2.771	2.271	300	19.780	4.499	5.493	2.604	1.895	1.213
eco-LSWE 10-6N18	15.415	11.960	21.185	(2)30	55,3	5,5	2.771	2.271	300	19.925	4.499	5.493	2.604	1.895	1.213

† Model Number will end in "-Z" for units with Series Flow piping configuration. Series Flow units may require additional coil connections and will require crossover piping. Model numbers will include "I" for units with Intake Attenuation, "D" for units with Discharge Attenuation, "F" for units with Full Sound Attenuation, "T" for units with a Tapered Discharge Hood, and "S" for units with an option that negates CTI Certification.

* Heaviest section is the coil section.

** Liters shown is water in suspension in unit and piping. Allow for additional water in bottom of remote sump to cover pump suction and strainer during operation (305 mm would normally be sufficient).

Δ When a remote sump arrangement is selected, the spray pump, suction strainer and associated piping are omitted; the unit is provided with an oversized outlet to facilitate drainage to the remote sump.

▲ Unit dimensions and coil connections may vary slightly from catalog. See factory certified prints for dimensions, quantity of coil connections, and piping configuration. Coil connections are 100 mm bevel for weld (BFW), also available as options. Other connection types such as grooved for mechanical coupling or flanged are also available as options.

Models: eco-LSWE 10-3M24 to 10-6P24

Closed Circuit Coolers

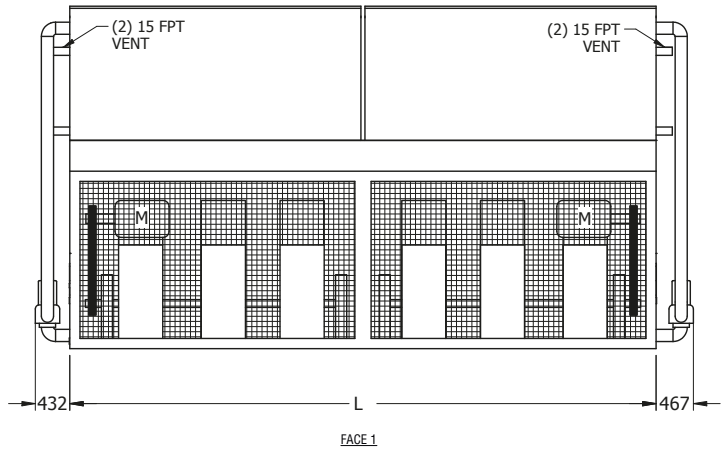
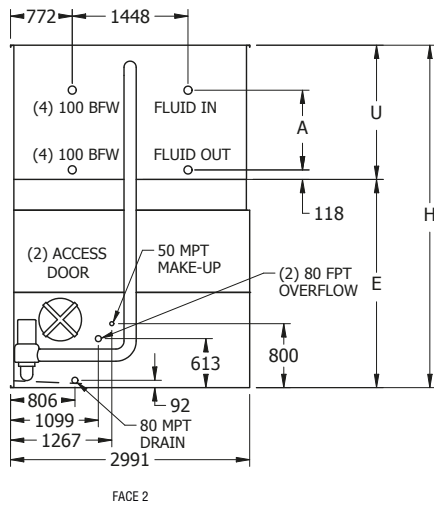
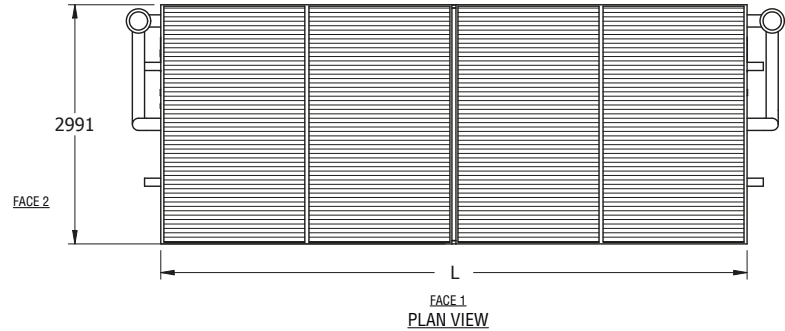

Model No. †	WEIGHTS (kg)			FANS		SPRAYPUMP	Coil Volume (Liters)	REMOTE SUMP Δ			DIMENSIONS ▲				
	Shipping	Heaviest Section*	Operating	kW	m³/s	kW		Liters Req'd**	Conn. Size	Operating Weight (kg)	Height H	Length L	Lower E	Upper U	Coil A
eco-LSWE 10-3M24	13.315	4.570	19.260	(2) 22	64,5	(2) 4	1.918	3.104	(2) 250	17.475	3.851	7.347	2.604	1.248	565
eco-LSWE 10-3N24	13.465	4.570	19.405	(2) 30	71	(2) 4	1.918	3.104	(2) 250	17.765	3.851	7.347	2.604	1.248	565
eco-LSWE 10-3O24	13.470	4.570	19.415	(2) 37	76,5	(2) 4	1.918	3.104	(2) 250	17.785	3.851	7.347	2.604	1.248	565
eco-LSWE 10-4M24	15.695	5.760	22.235	(2) 22	63,3	(2) 4	2.515	3.104	(2) 250	20.600	4.067	7.347	2.604	1.464	781
eco-LSWE 10-4N24	15.840	5.760	22.380	(2) 30	69,6	(2) 4	2.515	3.104	(2) 250	20.890	4.067	7.347	2.604	1.464	781
eco-LSWE 10-4O24	15.850	5.760	22.390	(2) 37	75	(2) 4	2.515	3.104	(2) 250	20.910	4.067	7.347	2.604	1.464	781
eco-LSWE 10-5M24	17.980	6.905	25.120	(2) 22	62	(2) 4	3.113	3.104	(2) 250	23.630	4.283	7.347	2.604	1.680	997
eco-LSWE 10-5N24	18.125	6.905	25.265	(2) 30	68,2	(2) 4	3.113	3.104	(2) 250	23.920	4.283	7.347	2.604	1.680	997
eco-LSWE 10-5O24	18.135	6.905	25.275	(2) 37	73,5	(2) 4	3.113	3.104	(2) 250	23.940	4.283	7.347	2.604	1.680	997
eco-LSWE 10-6M24	20.350	8.090	28.075	(2) 22	60,7	(2) 4	3.711	3.104	(2) 250	26.740	4.499	7.347	2.604	1.895	1.213
eco-LSWE 10-6N24	20.495	8.090	28.225	(2) 30	66,8	(2) 4	3.711	3.104	(2) 250	27.030	4.499	7.347	2.604	1.895	1.213
eco-LSWE 10-6O24	20.500	8.090	28.230	(2) 37	72	(2) 4	3.711	3.104	(2) 250	27.050	4.499	7.347	2.604	1.895	1.213
eco-LSWE 10-6P24	20.685	8.090	28.415	(2) 45	76,5	(2) 4	3.711	3.104	(2) 250	27.410	4.499	7.347	2.604	1.895	1.213

† Model Number will end in "-Z" for units with Series Flow piping configuration. Series Flow units may require additional coil connections and will require crossover piping. Model numbers will include "I" for units with Intake Attenuation, "D" for units with Discharge Attenuation, "F" for units with Full Sound Attenuation, "T" for units with a Tapered Discharge Hood, and "S" for units with an option that negates CTI Certification.

* Heaviest section is the coil section.

** Liters shown is water in suspension in unit and piping. Allow for additional water in bottom of remote sump to cover pump suction and strainer during operation (305 mm would normally be sufficient).

Δ When a remote sump arrangement is selected, the spray pump, suction strainer and associated piping are omitted; the unit is provided with an oversized outlet to facilitate drainage to the remote sump.

▲ Unit dimensions and coil connections may vary slightly from catalog. See factory certified prints for dimensions, quantity of coil connections, and piping configuration. Coil connections are 100 mm bevel for weld (BFW), also available as options. Other connection types such as grooved for mechanical coupling or flanged are also available as options.

Models: eco-LSWE 10-3K36 to 10-6N36

Closed Circuit Coolers

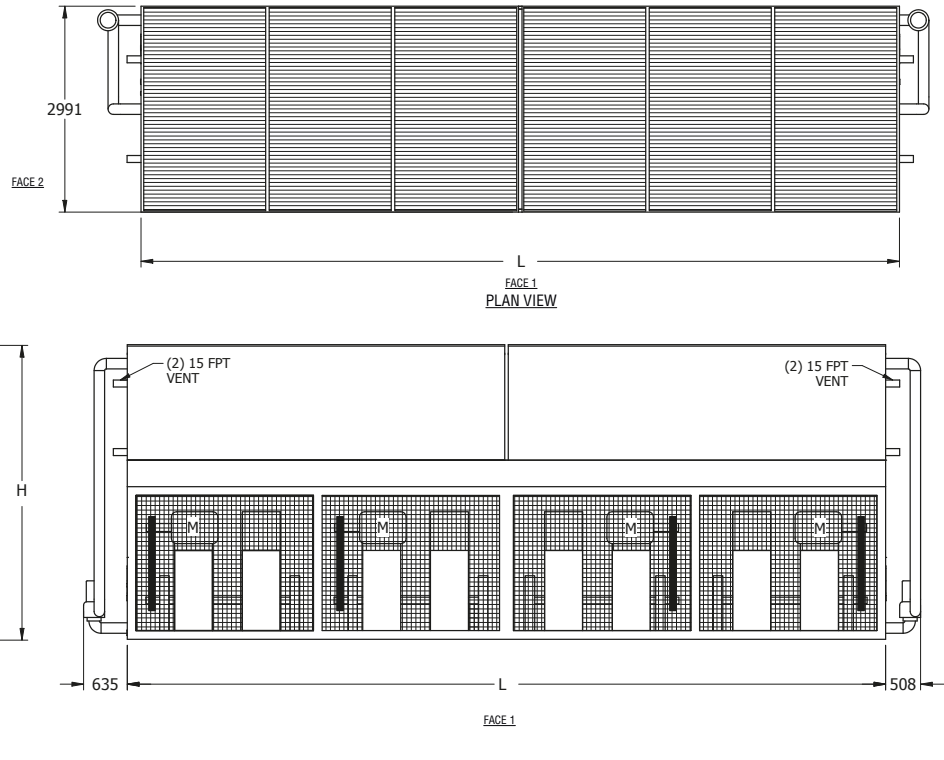

Note: The number of coil connections may increase based on design flow rate.

Model No. †	WEIGHTS (kg)			FANS		SPRAY PUMP	Coil Volume (Liters)	REMOTE SUMP Δ			DIMENSIONS ▲				
	Shipping	Heaviest Section*	Operating	kW	m³/s	kW		Liters Req'd**	Conn. Size	Operating Weight (kg)	Height H	Length L	Lower E	Upper U	Coil A
eco-LSWE 10-3K36	19.885	6.720	28.735	(4)15	93,3	(2) 5,5	2.833	5.678	(2) 300	26.260	3.851	11.036	2.604	1.248	565
eco-LSWE 10-3L36	19.940	6.720	28.790	(4)18.5	100,5	(2) 5,5	2.833	5.678	(2) 300	26.365	3.851	11.036	2.604	1.248	565
eco-LSWE 10-3M36	20.030	6.720	28.880	(4)22	106,8	(2) 5,5	2.833	5.678	(2) 300	26.550	3.851	11.036	2.604	1.248	565
eco-LSWE 10-3N36	20.320	6.875	29.170	(4)30	117,5	(2) 5,5	2.833	5.678	(2) 300	27.130	3.851	11.036	2.604	1.248	565
eco-LSWE 10-4L36	23.470	8.485	33.215	(4)18.5	98,5	(2) 5,5	3.736	5.678	(2) 300	30.990	4.067	11.036	2.604	1.464	781
eco-LSWE 10-4M36	23.560	8.485	33.305	(4)22	104,7	(2) 5,5	3.736	5.678	(2) 300	31.170	4.067	11.036	2.604	1.464	781
eco-LSWE 10-4N36	23.850	8.485	33.600	(4)30	115,2	(2) 5,5	3.736	5.678	(2) 300	31.750	4.067	11.036	2.604	1.464	781
eco-LSWE 10-5L36	26.890	10.195	37.545	(4)18.5	96,5	(2) 5,5	4.639	5.678	(2) 300	35.555	4.283	11.036	2.604	1.680	997
eco-LSWE 10-5M36	26.980	10.195	37.635	(4)22	102,6	(2) 5,5	4.639	5.678	(2) 300	35.735	4.283	11.036	2.604	1.680	997
eco-LSWE 10-5N36	27.270	10.195	37.925	(4)30	112,9	(2) 5,5	4.639	5.678	(2) 300	36.315	4.283	11.036	2.604	1.680	997
eco-LSWE 10-6L36	30.410	11.955	41.960	(4)18.5	94,6	(2) 5,5	5.542	5.678	(2) 300	40.205	4.499	11.036	2.604	1.895	1.213
eco-LSWE 10-6M36	30.500	11.955	42.055	(4)22	100,5	(2) 5,5	5.542	5.678	(2) 300	40.390	4.499	11.036	2.604	1.895	1.213
eco-LSWE 10-6N36	30.790	11.955	42.345	(4)30	110,6	(2) 5,5	5.542	5.678	(2) 300	40.970	4.499	11.036	2.604	1.895	1.213

† Model Number will end in "-Z" for units with Series Flow piping configuration. Series Flow units may require additional coil connections and will require crossover piping. Model numbers will include "I" for units with Intake Attenuation, "D" for units with Discharge Attenuation, "F" for units with Full Sound Attenuation, "T" for units with a Tapered Discharge Hood, and "S" for units with an option that negates CTI Certification.

* Heaviest section is the coil section.

** Liters shown is water in suspension in unit and piping. Allow for additional water in bottom of remote sump to cover pump suction and strainer during operation (305 mm would normally be sufficient).

Δ When a remote sump arrangement is selected, the spray pump, suction strainer and associated piping are omitted; the unit is provided with an oversized outlet to facilitate drainage to the remote sump.

▲ Unit dimensions and coil connections may vary slightly from catalog. See factory certified prints for dimensions, quantity of coil connections, and piping configuration. Coil connections are 100 mm bevel for weld (BFW), also available as options. Other connection types such as grooved for mechanical coupling or flanged are also available as options.

Models: eco-LRWB 3-2D6 to 3-516

Closed Circuit Coolers

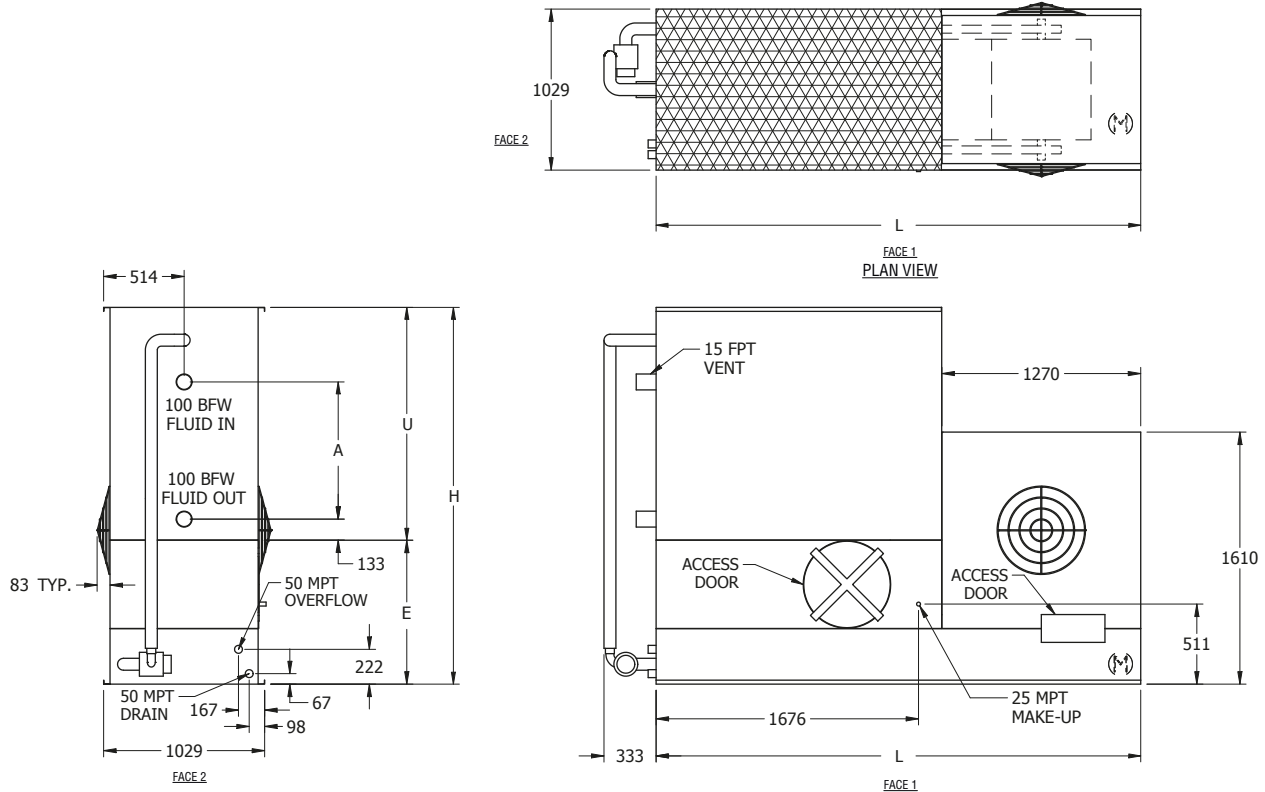

Model No. †	WEIGHTS (kg)			FANS		SPRAY PUMP	Coil Volume (Liters)	REMOTE SUMP Δ				DIMENSIONS ▲				
	Shipping	Heaviest Section*	Operating	kW	m³/s	kW		Liters Req'd**	Conn. Size	Operating Weight (kg)	Height H	Length L	Lower E	Upper U	Coil A	
eco-LRWB 3-2D6	1.100	685	1.655	1,1	3,6	0,37	115	125	100	1.250	1.835	3.096	921	914	305	
eco-LRWB 3-2E6	1.100	685	1.655	1,5	3,9	0,37	115	125	100	1.250	1.835	3.096	921	914	305	
eco-LRWB 3-2F6	1.110	685	1.670	2,2	4,5	0,37	115	125	100	1.265	1.835	3.096	921	914	305	
eco-LRWB 3-2G6	1.115	685	1.675	4	5,3	0,37	115	125	100	1.270	1.835	3.096	921	914	305	
eco-LRWB 3-2H6	1.140	685	1.695	5,5	6,1	0,37	115	125	100	1.295	1.835	3.096	921	914	305	
eco-LRWB 3-3E6	1.280	865	1.880	1,5	3,9	0,37	162	125	100	1.480	2.026	3.096	921	1.105	495	
eco-LRWB 3-3F6	1.295	865	1.895	2,2	4,4	0,37	162	125	100	1.490	2.026	3.096	921	1.105	495	
eco-LRWB 3-3G6	1.295	865	1.900	4	5,2	0,37	162	125	100	1.495	2.026	3.096	921	1.105	495	
eco-LRWB 3-3H6	1.320	865	1.925	5,5	6	0,37	162	125	100	1.520	2.026	3.096	921	1.105	495	
eco-LRWB 3-4E6	1.475	1.060	2.125	1,5	3,8	0,37	208	125	100	1.720	2.216	3.096	921	1.295	686	
eco-LRWB 3-4F6	1.490	1.060	2.135	2,2	4,3	0,37	208	125	100	1.735	2.216	3.096	921	1.295	686	
eco-LRWB 3-4G6	1.490	1.060	2.140	4	5,1	0,37	208	125	100	1.735	2.216	3.096	921	1.295	686	
eco-LRWB 3-4H6	1.515	1.060	2.165	5,5	5,9	0,37	208	125	100	1.760	2.216	3.096	921	1.295	686	
eco-LRWB 3-5F6	1.690	1.265	2.390	2,2	4,3	0,37	255	125	100	1.990	2.407	3.096	921	1.486	876	
eco-LRWB 3-5G6	1.695	1.265	2.395	4	5	0,37	255	125	100	1.995	2.407	3.096	921	1.486	876	
eco-LRWB 3-5H6	1.720	1.265	2.420	5,5	5,8	0,37	255	125	100	2.020	2.407	3.096	921	1.486	876	
eco-LRWB 3-516	1.730	1.265	2.425	7,5	6,3	0,37	255	125	100	2.030	2.407	3.096	921	1.486	876	

† Model Number will end in "-Z" for units with Series Flow piping configuration. Series Flow units may require additional coil connections and will require crossover piping. Model numbers will include "I" for units with Intake Attenuation, "D" for units with Discharge Attenuation, "F" for units with Full Sound Attenuation, "T" for units with a Tapered Discharge Hood, and "S" for units with an option that negates CTI Certification.

** Liters shown is water in suspension in unit and piping. Allow for additional water in bottom of remote sump to cover pump suction and strainer during operation (305 mm would normally be sufficient).

Δ When a remote sump arrangement is selected, the spray pump, suction strainer and associated piping are omitted; the unit is provided with an oversized outlet to facilitate drainage to the remote sump.

▲ Unit dimensions and coil connections may vary slightly from catalog. See factory certified prints for dimensions, quantity of coil connections, and piping configuration. Coil connections are 100 mm bevel for weld (BFW), also available as options. Other connection types such as grooved for mechanical coupling or flanged are also available as options.

Models: eco-LRWB 5-2F6 to 5-5I6

Closed Circuit Coolers

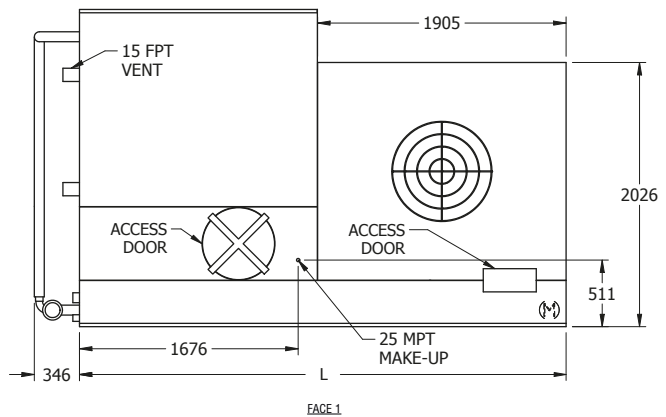
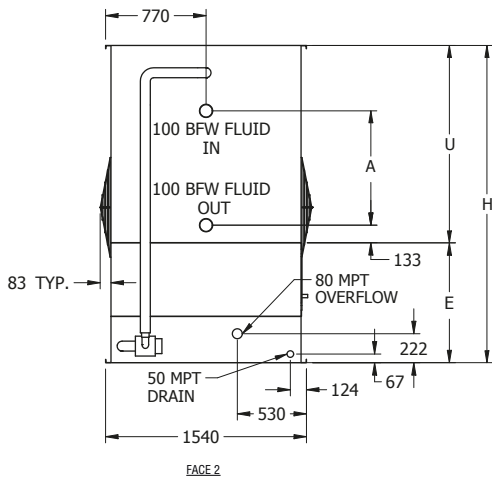
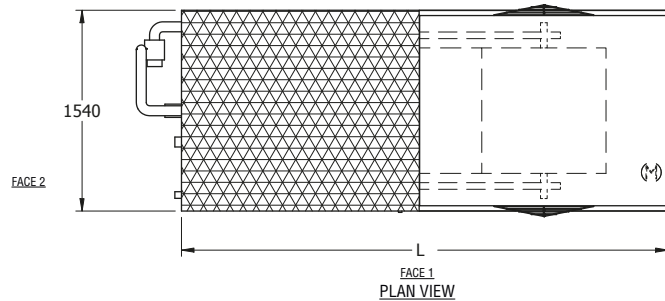

Note: The number of coil connections may increase based on design flow rate.

Model No. †	WEIGHTS (kg)			FANS		SPRAY PUMP	Coil Volume (Liters)	REMOTE SUMP Δ			DIMENSIONS ▲				
	Shipping	Heaviest Section*	Operating	kW	m³/s	kW		Liters Req'd**	Conn. Size	Operating Weight (kg)	Height H	Length L	Lower E	Upper U	Coil A
eco-LRWB 5-2F6	1.660	965	2.620	2,2	6,5	0,75	177	454	150	1930	1835	3,731	921	914	305
eco-LRWB 5-2G6	1.665	965	2.625	4	7,7	0,75	177	454	150	1.935	1835	3,731	921	914	305
eco-LRWB 5-2H6	1.685	965	2.650	5,5	8,8	0,75	177	454	150	1.960	1835	3,731	921	914	305
eco-LRWB 5-2I6	1.695	965	2.660	7,5	9,7	0,75	177	454	150	1.970	1835	3,731	921	914	305
eco-LRWB 5-3F6	1.945	1.250	2.980	2,2	6,4	0,75	251	454	150	2.290	2.026	3,731	921	1.105	495
eco-LRWB 5-3G6	1.950	1.250	2.985	4	7,6	0,75	251	454	150	2.295	2.026	3,731	921	1.105	495
eco-LRWB 5-3H6	1.975	1.250	3.005	5,5	8,7	0,75	251	454	150	2.320	2.026	3,731	921	1.105	495
eco-LRWB 5-3I6	1.980	1.250	3.015	7,5	9,5	0,75	251	454	150	2.325	2.026	3,731	921	1.105	495
eco-LRWB 5-4G6	2.245	1.545	3.350	4	7,4	0,75	324	454	150	2.660	2.216	3,731	921	1.295	686
eco-LRWB 5-4H6	2.270	1.545	3.375	5,5	8,5	0,75	324	454	150	2.680	2.216	3,731	921	1.295	686
eco-LRWB 5-4I6	2.275	1.545	3.385	7,5	9,4	0,75	324	454	150	2.690	2.216	3,731	921	1.295	686
eco-LRWB 5-5G6	2.565	1.865	3.740	4	7,3	0,75	397	454	150	3.050	2.407	3,731	921	1.486	876
eco-LRWB 5-5H6	2.585	1.865	3.765	5,5	8,3	0,75	397	454	150	3.070	2.407	3,731	921	1.486	876
eco-LRWB 5-5I6	2.595	1.865	3.775	7,5	9,2	0,75	397	454	150	3.080	2.407	3,731	921	1.486	876

† Model Number will end in "-Z" for units with Series Flow piping configuration. Series Flow units may require additional coil connections and will require crossover piping. Model numbers will include "I" for units with Intake Attenuation, "D" for units with Discharge Attenuation, "F" for units with Full Sound Attenuation, "T" for units with a Tapered Discharge Hood, and "S" for units with an option that negates CTI Certification.

** Liters shown is water in suspension in unit and piping. Allow for additional water in bottom of remote sump to cover pump suction and strainer during operation (305 mm would normally be sufficient).

Δ When a remote sump arrangement is selected, the spray pump, suction strainer and associated piping are omitted; the unit is provided with an oversized outlet to facilitate drainage to the remote sump.

▲ Unit dimensions and coil connections may vary slightly from catalog. See factory certified prints for dimensions, quantity of coil connections, and piping configuration. Coil connections are 100 mm bevel for weld (BFW), also available as options. Other connection types such as grooved for mechanical coupling or flanged are also available as options.

Models: eco-LRWB 5-3H9 to 5-6K9

Closed Circuit Coolers

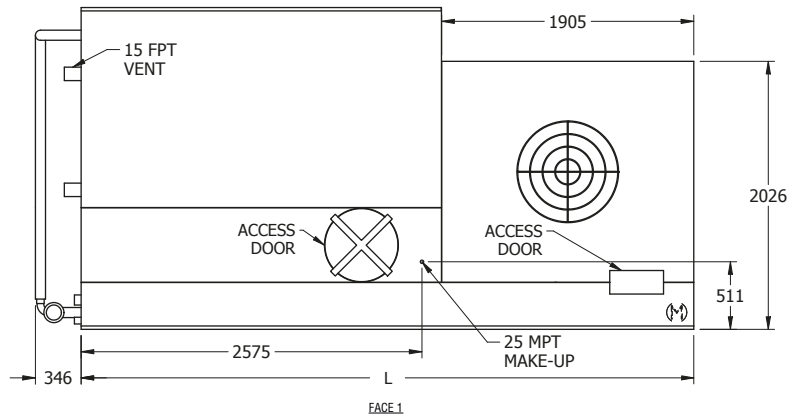
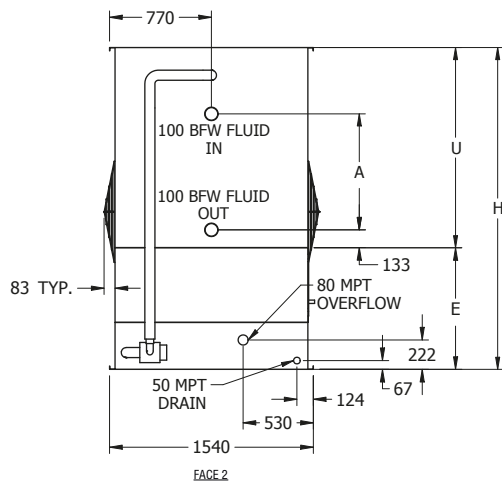
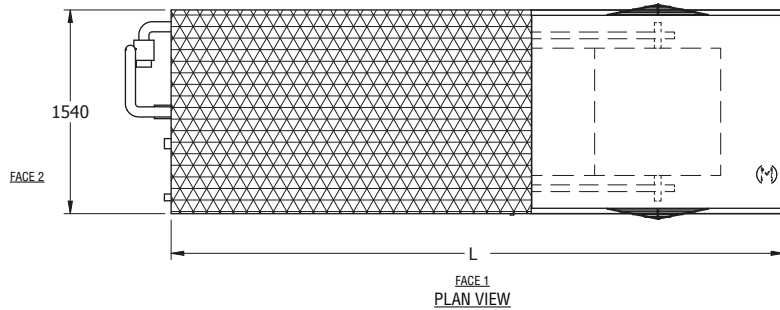

Model No. †	WEIGHTS (kg)			FANS		SPRAYPUMP	Coil Volume (Liters)	REMOTE SUMP Δ			DIMENSIONS ▲				
	Shipping	Heaviest Section**	Operating	kW	m³/s	kW		Liters Req'd**	Conn. Size	Operating Weight (kg)	Height H	Length L	Lower E	Upper U	Coil A
eco-LRWB 5-3H9	2.580	1.800	4.120	5,5	10,6	1,1	365	644	150	3.120	2.026	4.629	921	1.105	495
eco-LRWB 5-3I9	2.590	1.800	4.130	7,5	11,7	1,1	365	644	150	3.130	2.026	4.629	921	1.105	495
eco-LRWB 5-3J9	2.645	1.800	4.180	11	13,4	1,1	365	644	150	3.185	2.026	4.629	921	1.105	495
eco-LRWB 5-3K9	2.670	1.800	4.210	15	14,7	1,1	365	644	150	3.210	2.026	4.629	921	1.105	495
eco-LRWB 5-4I9	3.040	2.250	4.685	7,5	11,4	1,1	476	644	150	3.690	2.216	4.629	921	1.295	686
eco-LRWB 5-4J9	3.095	2.250	4.740	11	13,1	1,1	476	644	150	3.740	2.216	4.629	921	1.295	686
eco-LRWB 5-4K9	3.120	2.250	4.765	15	14,4	1,1	476	644	150	3.770	2.216	4.629	921	1.295	686
eco-LRWB 5-5I9	3.500	2.710	5.260	7,5	11,2	1,1	588	644	150	4.265	2.407	4.629	921	1.486	876
eco-LRWB 5-5J9	3.555	2.710	5.315	11	12,8	1,1	588	644	150	4.320	2.407	4.629	921	1.486	876
eco-LRWB 5-5K9	3.585	2.710	5.345	15	14,1	1,1	588	644	150	4.345	2.407	4.629	921	1.486	876
eco-LRWB 5-6I9	3.910	3.120	5.780	7,5	11	1,1	699	644	150	4.780	2.597	4.629	921	1.676	1.067
eco-LRWB 5-6J9	3.965	3.120	5.835	11	12,6	1,1	699	644	150	4.835	2.597	4.629	921	1.676	1.067
eco-LRWB 5-6K9	3.990	3.120	5.860	15	13,8	1,1	699	644	150	4.865	2.597	4.629	921	1.676	1.067

† Model Number will end in "-Z" for units with Series Flow piping configuration. Series Flow units may require additional coil connections and will require crossover piping. Model numbers will include "I" for units with Intake Attenuation, "D" for units with Discharge Attenuation, "F" for units with Full Sound Attenuation, "T" for units with a Tapered Discharge Hood, and "S" for units with an option that negates CTI Certification.

** Liters shown is water in suspension in unit and piping. Allow for additional water in bottom of remote sump to cover pump suction and strainer during operation (305 mm would normally be sufficient).

Δ When a remote sump arrangement is selected, the spray pump, suction strainer and associated piping are omitted; the unit is provided with an oversized outlet to facilitate drainage to the remote sump.

▲ Unit dimensions and coil connections may vary slightly from catalog. See factory certified prints for dimensions, quantity of coil connections, and piping configuration. Coil connections are 100 mm bevel for weld (BFW), also available as options. Other connection types such as grooved for mechanical coupling or flanged are also available as options.

Models: eco-LRWB 5-3J12 to 5-6N12

Closed Circuit Coolers

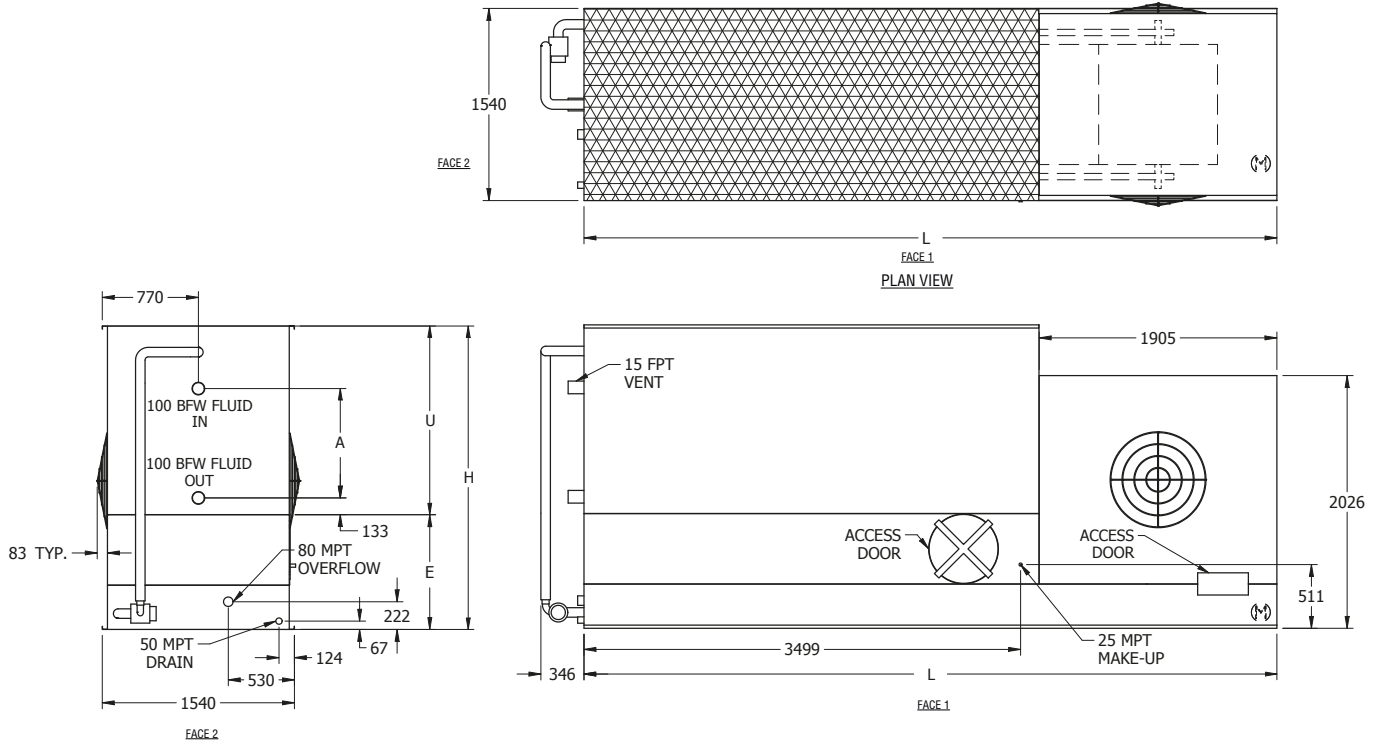

Note: The number of coil connections may increase based on design flow rate.

Model No. †	WEIGHTS (kg)			FANS		SPRAY PUMP	Coil Volume (Liters)	REMOTE SUMP Δ			DIMENSIONS ▲				
	Shipping	Heaviest Section**	Operating	kW	m ³ /s	kW		Liters Req'd**	Conn. Size	Operating Weight (kg)	Height H	Length L	Lower E	Upper U	Coil A
eco-LRWB 5-3J12	3.215	2.275	5.290	11	15	1,5	479	908	200	3.975	2.051	5.553	921	1.130	495
eco-LRWB 5-3K12	3.245	2.275	5.315	15	16,5	1,5	479	908	200	4.000	2.051	5.553	921	1.130	495
eco-LRWB 5-3L12	3.255	2.275	5.330	18,5	17,7	1,5	479	908	200	4.015	2.051	5.553	921	1.130	495
eco-LRWB 5-3M12	3.280	2.275	5.350	22	18,9	1,5	479	908	200	4.035	2.051	5.553	921	1.130	495
eco-LRWB 5-4J12	3.820	2.880	6.040	11	14,7	1,5	629	908	200	4.725	2.242	5.553	921	1.321	686
eco-LRWB 5-4K12	3.845	2.880	6.070	15	16,1	1,5	629	908	200	4.755	2.242	5.553	921	1.321	686
eco-LRWB 5-4L12	3.860	2.880	6.085	18,5	17,4	1,5	629	908	200	4.765	2.242	5.553	921	1.321	686
eco-LRWB 5-4M12	3.885	2.880	6.105	22	18,5	1,5	629	908	200	4.790	2.242	5.553	921	1.321	686
eco-LRWB 5-5K12	4.435	3.470	6.810	15	15,8	1,5	778	908	200	5.495	2.432	5.553	921	1.511	876
eco-LRWB 5-5L12	4.450	3.470	6.820	18,5	17	1,5	778	908	200	5.505	2.432	5.553	921	1.511	876
eco-LRWB 5-5M12	4.470	3.470	6.845	22	18,1	1,5	778	908	200	5.530	2.432	5.553	921	1.511	876
eco-LRWB 5-5N12	4.545	3.470	6.915	30	19,9	1,5	778	908	200	5.600	2.432	5.553	921	1.511	876
eco-LRWB 5-6L12	5.010	4.030	7.530	18,5	16,7	1,5	928	908	200	6.215	2.623	5.553	921	1.702	1.067
eco-LRWB 5-6M12	5.030	4.030	7.550	22	17,7	1,5	928	908	200	6.235	2.623	5.553	921	1.702	1.067
eco-LRWB 5-6N12	5.105	4.030	7.625	30	19,5	1,5	928	908	200	6.310	2.623	5.553	921	1.702	1.067

† Model Number will end in "-Z" for units with Series Flow piping configuration. Series Flow units may require additional coil connections and will require crossover piping. Model numbers will include "I" for units with Intake Attenuation, "D" for units with Discharge Attenuation, "F" for units with Full Sound Attenuation, "T" for units with a Tapered Discharge Hood, and "S" for units with an option that negates CT1 Certification.

** Liters shown is water in suspension in unit and piping. Allow for additional water in bottom of remote sump to cover pump suction and strainer during operation (305 mm would normally be sufficient).

Δ When a remote sump arrangement is selected, the spray pump, suction strainer and associated piping are omitted; the unit is provided with an oversized outlet to facilitate drainage to the remote sump.

▲ Unit dimensions and coil connections may vary slightly from catalog. See factory certified prints for dimensions, quantity of coil connections, and piping configuration. Coil connections are 100 mm bevel for weld (BFW), also available as options. Other connection types such as grooved for mechanical coupling or flanged are also available as options.

Models: eco-LRWB 8-3J9 to 8-6O12

Closed Circuit Coolers

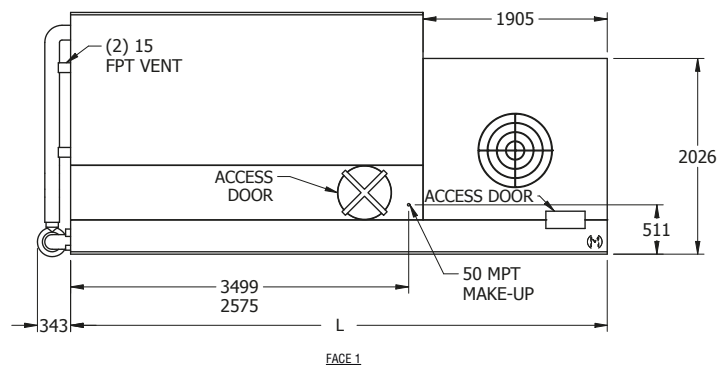
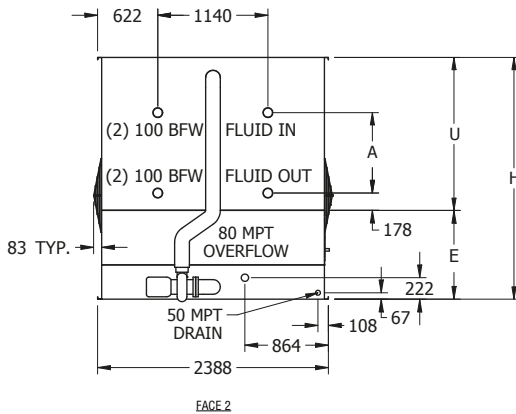
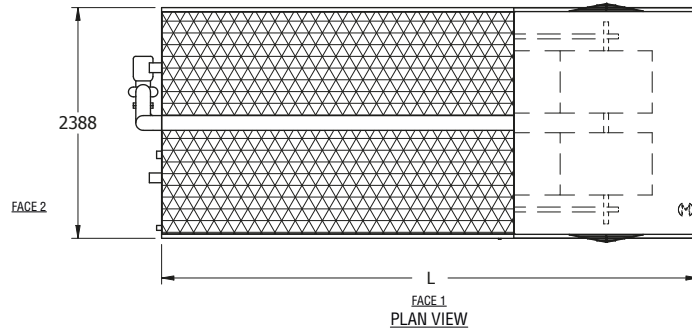

Model No. †	WEIGHTS (kg)			FANS		SPRAY PUMP	Coil Volume (Liters)	REMOTE SUMP Δ			DIMENSIONS ▲				
	Shipping	Heaviest Section*	Operating	kW	m³/s	kW		Liters Req'd**	Conn. Size	Operating Weight (kg)	Height H	Length L	Lower E	Upper U	Coil A
eco-LRWB 8-3J9	3.970	2.780	6.085	11	17,9	1,5	576	946	200	4.620	2.121	4.629	921	1.200	495
eco-LRWB 8-3K9	3.995	2.780	6.110	15	19,7	1,5	576	946	200	4.650	2.121	4.629	921	1.200	495
eco-LRWB 8-3L9	4.010	2.780	6.125	18,5	21,3	1,5	576	946	200	4.665	2.121	4.629	921	1.200	495
eco-LRWB 8-3M9	4.030	2.780	6.145	22	22,6	1,5	576	946	200	4.685	2.121	4.629	921	1.200	495
eco-LRWB 8-4J9	4.645	3.455	6.935	11	17,6	1,5	751	946	200	5.475	2.311	4.629	921	1.391	686
eco-LRWB 8-4K9	4.670	3.455	6.965	15	19,4	1,5	751	946	200	5.500	2.311	4.629	921	1.391	686
eco-LRWB 8-4L9	4.685	3.455	6.975	18,5	20,8	1,5	751	946	200	5.515	2.311	4.629	921	1.391	686
eco-LRWB 8-4M9	4.710	3.455	7.000	22	22,2	1,5	751	946	200	5.540	2.311	4.629	921	1.391	686
eco-LRWB 8-5K9	5.480	4.265	7.945	15	19	1,5	926	946	200	6.485	2.502	4.629	921	1.581	876
eco-LRWB 8-5L9	5.495	4.265	7.960	18,5	20,4	1,5	926	946	200	6.500	2.502	4.629	921	1.581	876
eco-LRWB 8-5M9	5.515	4.265	7.985	22	21,7	1,5	926	946	200	6.525	2.502	4.629	921	1.581	876
eco-LRWB 8-4K12	5.695	4.435	8.815	15	22,6	2,2	991	1.363	250	6.850	2.311	5.553	921	1.391	686
eco-LRWB 8-4L12	5.710	4.435	8.825	18,5	24,3	2,2	991	1.363	250	6.865	2.311	5.553	921	1.391	686
eco-LRWB 8-4M12	5.735	4.435	8.850	22	25,9	2,2	991	1.363	250	6.885	2.311	5.553	921	1.391	686
eco-LRWB 8-4N12	5.805	4.435	8.920	30	28,5	2,2	991	1.363	250	6.960	2.311	5.553	921	1.391	686
eco-LRWB 8-4O12	5.810	4.435	8.925	37	30,7	2,2	991	1.363	250	6.965	2.311	5.553	921	1.391	686
eco-LRWB 8-5L12	6.620	5.350	9.975	18,5	23,9	2,2	1.227	1.363	250	8.010	2.502	5.553	921	1.581	876
eco-LRWB 8-5M12	6.645	5.350	9.995	22	25,3	2,2	1.227	1.363	250	8.035	2.502	5.553	921	1.581	876
eco-LRWB 8-5N12	6.720	5.350	10.070	30	27,9	2,2	1.227	1.363	250	8.105	2.502	5.553	921	1.581	876
eco-LRWB 8-5O12	6.720	5.350	10.075	37	30,1	2,2	1.227	1.363	250	8.110	2.502	5.553	921	1.581	876
eco-LRWB 8-6M12	7.520	6.225	11.110	22	24,8	2,2	1.462	1.363	250	9.145	2.692	5.553	921	1.772	1.067
eco-LRWB 8-6N12	7.595	6.225	11.180	30	27,3	2,2	1.462	1.363	250	9.215	2.692	5.553	921	1.772	1.067
eco-LRWB 8-6O12	7.600	6.225	11.185	37	29,4	2,2	1.462	1.363	250	9.220	2.692	5.553	921	1.772	1.067

† Model Number will end in "-Z" for units with Series Flow piping configuration. Series Flow units may require additional coil connections and will require crossover piping. Model numbers will include "I" for units with Intake Attenuation, "D" for units with Discharge Attenuation, "F" for units with Full Sound Attenuation, "T" for units with a Tapered Discharge Hood, and "S" for units with an option that negates CTI Certification.

** Liters shown is water in suspension in unit and piping. Allow for additional water in bottom of remote sump to cover pump suction and strainer during operation (305 mm would normally be sufficient).

Δ When a remote sump arrangement is selected, the spray pump, suction strainer and associated piping are omitted; the unit is provided with an oversized outlet to facilitate drainage to the remote sump.

▲ Unit dimensions and coil connections may vary slightly from catalog. See factory certified prints for dimensions, quantity of coil connections, and piping configuration. Coil connections are 100 mm bevel for weld (BFW), also available as options. Other connection types such as grooved for mechanical coupling or flanged are also available as options.



WORLDWIDE MANUFACTURING FACILITIES



- World Headquarters/ Research and Development Center
- EVAPCO Facilities

EVAPCO, Inc. — World Headquarters & Research / Development Center

P.O. Box 1300 • Westminster, MD 21158 USA
410-756-2600 p • 410-756-6450 f • marketing@evapco.com

North America

EVAPCO, Inc.
World Headquarters
P.O. Box 1300
Westminster, MD 21158 USA
410-756-2600 p | 410-756-6450 f
marketing@evapco.com

EVAPCO East
5151 Allendale Lane
Taneytown, MD 21787 USA
410-756-2600 p | 410-756-6450 f
marketing@evapco.com

EVAPCO Midwest
1723 York Road
Greenup, IL 62428 USA
217-923-3431 p | 217-923-3300 f
evapcomw@evapcomw.com

EVAPCO West
1900 West Almond Avenue
Madera, CA 93637 USA
559-673-2207 p | 559-673-2378 f
contact@evapcowest.com

EVAPCO Iowa
925 Quality Drive
Lake View, IA 51450 USA
712-657-3223 p | 712-657-3226 f

EVAPCO Iowa Sales & Engineering
215 1st Street, NE
P.O. Box 88
Medford, MN 55049 USA
507-446-8005 p | 507-446-8239 f
evapcomn@evapcomn.com

EVAPCO Newton
701 East Jourdan Street
Newton, IL 62448 USA
618-783-3433 | 618-783-3499 f
evapcomw@evapcomw.com

EVAPCOLD
521 Evapco Drive
Greenup, Ill USA
217-923-3431 p
evapcomw@evapcomw.com

EVAPCO-Dry Cooling, Inc.
981 US Highway 22 West
Bridgewater, New Jersey 08807 USA
1-908-379-2665 p
info@evapco-blct.com

Refrigeration Valves & Systems Corporation
A wholly owned subsidiary of EVAPCO, Inc.
1520 Crosswind Dr.
Bryan, TX 77808 USA
979-778-0095 p | 979-778-0030 f
rvs@rvscorp.com

EVAPCO Northwest
5775 S.W. Jean Road, Suite 210
Lake Oswego, Oregon 97035 USA
503-639-2137 p | 503-639-1800 f

EvapTech, Inc.
A wholly owned subsidiary of EVAPCO, Inc.
8331 Nieman Road
Lenexa, KS 66214 USA
913-322-5165 p | 913-322-5166 f
marketing@evaptech.com

Tower Components, Inc.
A wholly owned subsidiary of EVAPCO, Inc.
5960 US HWY 64E
Ramseur, NC 27316
336-824-2102 p | 336-824-2190 f
mail@towercomponentsinc.com

South America

EVAPCO Brasil Equipamentos Industriais Ltda
Rua Alexandre Dumas, 1601 - 2 andar
04717-004 Sao Paulo - SP - Brazil
(55) 11-5184-0067 p

Europe

EVAPCO Europe BVBA
European Headquarters
Heersterveldweg 19, Industrieterrein Oost
3700 Tongeren, Belgium
(32) 12-395029 p | (32) 12-238527 f
evapco.europe@evapco.be

EVAPCO Europe, S.r.l.
Via Ciro Menotti 10
I-20017 Passirana di Rho, Milan, Italy
(39) 02-939-9041 p | (39) 02-935-00840 f
evapcoeuropa@evapco.it

EVAPCO Europe, S.r.l.
Via Dosso 2, 23020 Piateda Sondrio, Italy

EVAPCO Europe GmbH
Insterburger Strasse 18
40670 Meerbusch, Germany
(49) 2159-69560 p | (49) 2159-69561 f
info@evapco.de

EVAPCO Middle East DMCC
Reef Tower, 29th Level, Cluster O,
Jumeirah Lake Towers, P.O. Box 5003310
Dubai, U.A.E.
Ph: (971) 4-448 7242 - Fx: (971) 4-448 7112
info@evapco.ae

EVAPCO Air Solutions a/s
A wholly owned subsidiary of EVAPCO, Inc.
Knøsgårdvej 115
DK-9440 Aabybro Denmark
(45) 9824 4999 p | (45) 9824 4990 f
info@flexcoil.dk

EVAPCO S.A. (Pty.) Ltd.
A licensed manufacturer of EVAPCO, Inc.
18 Quality Road
Isando 1600, Republic of South Africa
(27) 11-392-6630 p | (27) 11-392-6615 f
evapco@evapco.co.za

Evap Egypt Engineering Industries Co.
A licensed manufacturer of EVAPCO, Inc.
5 El Nasr Road
Nasr City, Cairo, Egypt
2 02 24022866 / 2 02 24044997 p
2 02 24044667 / 2 02 24044668 f
Primacool/link.net/ / Shady@primacool.net

Asia/Pacific

EVAPCO Asia/Pacific Headquarters
1159 Luoning Rd. Baoshan Industrial Zone
Shanghai, P. R. China, Postal Code: 200949
(86) 21-6687-7786 p | (86) 21-6687-7008 f
marketing@evapcochina.com

EVAPCO (Shanghai) Refrigeration Equipment Co., Ltd.
1159 Luoning Rd., Baoshan Industrial Zone
Shanghai, P.R. China, Postal Code: 200949
(86) 21-6687-7786 p | (86) 21-6687-7008 f
marketing@evapcochina.com

Beijing EVAPCO Refrigeration Equipment Co., Ltd.
Yan Qi Industrial Development District
Huai Rou County
Beijing, P.R. China, Postal Code: 101407
(86) 10 6166-7238 p | (86) 10 6166-7395 f
evapcobj@evapcochina.com

EVAPCO Australia (Pty.) Ltd.
34-42 Melbourne Road
P.O. Box 436
Riverstone, N.S.W. Australia 2765
(61) 2 9627-3322 p | (61) 2 9627-1715 f
E-mail: sales@evapco.com.au

EVAPCO Composites Sdn. Bhd
No. 70 (Lot 1289) Jalan Industri 2/3
Rawang Integrated Industrial Park
Rawang, Selangor, 48000 Malaysia
60 3 6092-2209 p | 60 3 6092-2210 f

EvapTech Asia Pacific Sdn. Bhd
A wholly owned subsidiary of EvapTech, Inc.
B-6-1, IOI Boulevard
Jalan Kenari 5, Bandar Puchong Jaya
47170 Puchong, Selangor Darul Ehsan
Malaysia
(60-3) 8070-7255 p | (60-3) 8070-5731 f
E-mail: marketing-ap@evaptech.com

