

eco-Air Series

Equipment Layout Manual

FOR DRY, ADIABATIC AND SPRAY
FLUID COOLERS, CONDENSERS &
CO₂ GAS COOLERS

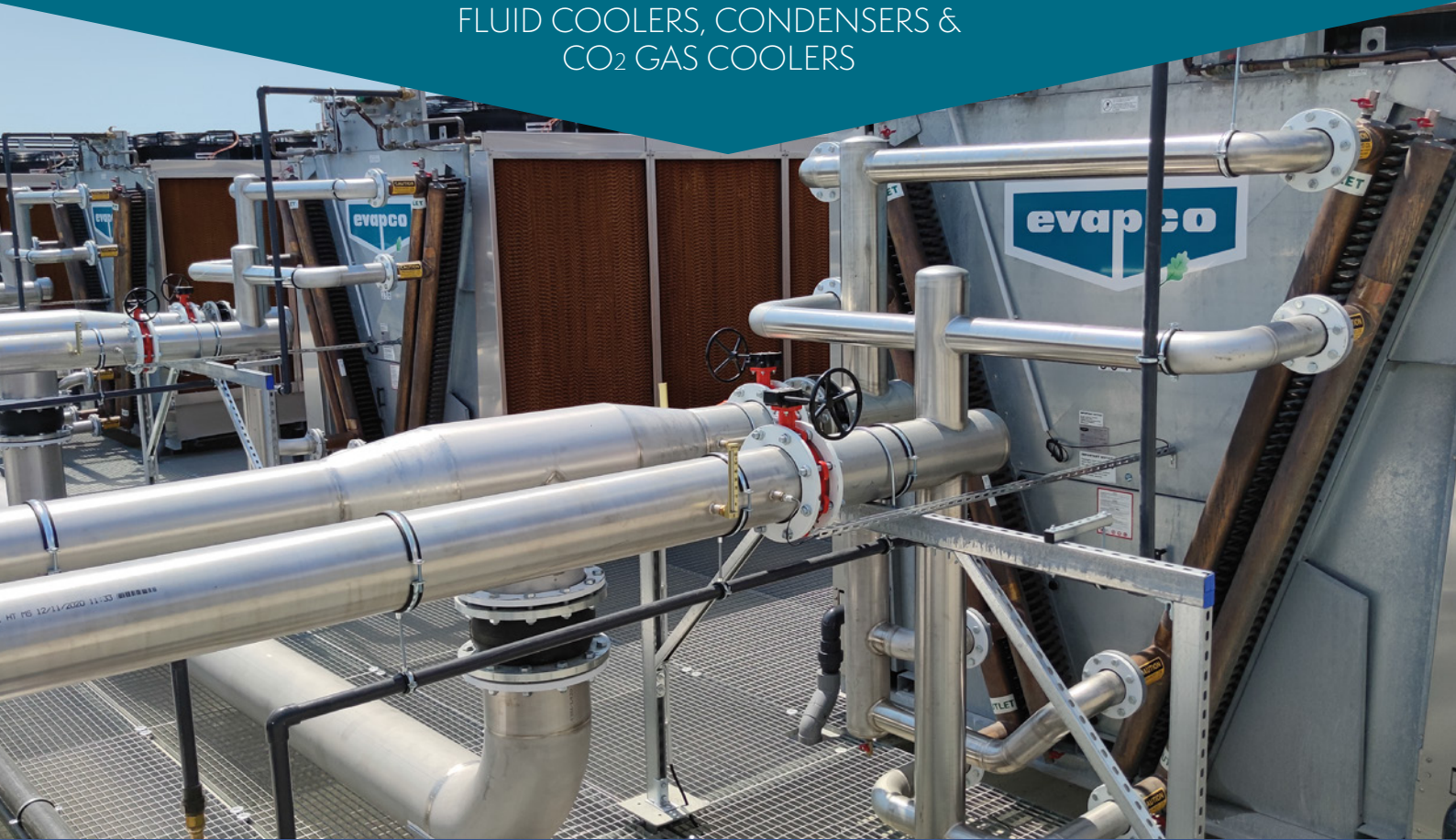

®
for LIFE

Commercial HVAC | Industrial Refrigeration |
Power Generation | Industrial Process |



Table of Contents

Introduction	2
Recirculation & Wind Considerations	3
Single & Multiple Unit Installation & Recommended Clearances	4
Large Installations	5
Expansions to Existing Systems	5
Maintenance & Electrical Spacing Considerations.....	5
Solid & Louvered Enclosures.....	6
Elevated Unit Installations	7

Introduction

This manual provides EVAPCO’s layout recommendations to ensure that the eco-Air unit(s) will operate at their rated capacity. These units use large quantities of air as the main source of cooling; therefore, maintaining adequate clearances around the units is crucial to their performance. This manual includes layout information such as clearances from walls and other eco-Air units, different types of enclosures, and large scale installations.

Prior to consulting EVAPCO’s recommended layout guidelines, consider context of the specific installation pertaining to space limitations, surrounding structures, existing units, proximity of neighbors, prevailing winds, piping, and any possible future expansion plans. For any alternate layouts which aren’t included in this manual, please contact EVAPCO or your local EVAPCO representative for assistance.

Product Lines Included In this Manual

This equipment layout manual provides guidelines for the eco-Air Series of Dry & Adiabatic Coolers & Condensers:

EAW-FD Flat Dry Cooler	EAFCD Flat Dry Condenser	EAFGD Flat Dry Gas Cooler
EAW-VD V-Coil Dry Cooler	EAVCD V-Coil Dry Condenser	EAVGD V-Coil Dry Gas Cooler
EAW-DD Double Stack Dry Cooler	EAVCA V-Coil Adiabatic Condenser	EAVGA V-Coil Adiabatic Gas Cooler
EAW-VS V-Coil Spray Cooler	EAVCS V-Coil Spray Condenser	
EAW-VA V-Coil Adiabatic Cooler		
EAW-DA Double Stack Adiabatic Cooler		

The guidelines for fluid coolers, CO₂ gas coolers and condensers are the same. This manual will refer to these products as Flat, V-Coil or Double Stack units. Any guidelines that are different for units equipped with adiabatic or spray systems are specifically outlined throughout this document. The layout guidelines recommended do not change for different types of fan assemblies.

Recirculation & Wind Considerations

EVAPCO’s recommended location of installation for any dry, adiabatic, or spray unit would be in an area free from any obstructions or structures. This ensures the hot discharge air is not recirculated into the pathway of the air inlets. When the discharge air is recirculated, the entering air will be hotter than the specified ambient conditions which, in turn, can cause the unit to underperform. Therefore, the position of the unit to an adjacent wall, building, or other structure must be considered to ensure proper airflow.

The first consideration in minimizing recirculation is the height of the unit relative to the height of the surrounding structure. The top of the unit must be equal to or higher than the structure. See the two following cases (Figure 1 and Figure 2) that show the effects of positioning the top of the unit lower than that of a nearby structure. If the wind is moving toward the structure, as shown in Figure 1, it will force the hot discharge air into the structure where it could be pushed into the direction of the unit’s air inlets. If the wind moves in the opposite direction, as shown in Figure 2, then the negative pressure created by the wind flowing over the structure and unit could force the discharge air back into the air inlets.

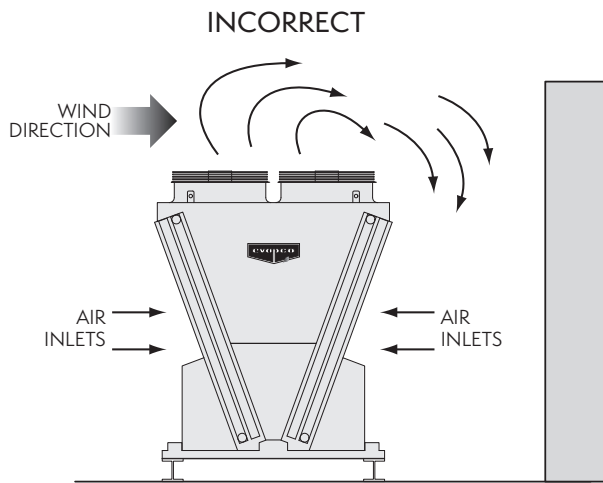

Figure 1 - Effect of Wind Directed Away from Surrounding Structure when Top of Unit is Lower Than Adjacent Structure

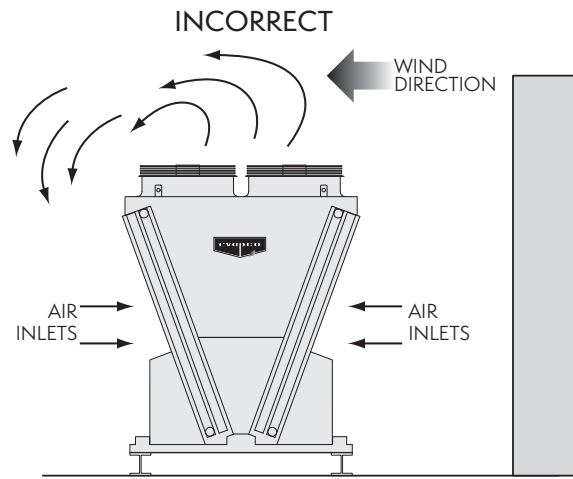

Figure 2 - Effect of Wind Directed Toward Surrounding Structure when Top of Unit is Lower Than Adjacent Structure

The negative impact of the conditions shown in Figure 1 and 2 can be reduced by elevating the unit on structural steel such that the top of the fan cowl is level with or higher than the adjacent structure, as shown in Figure 3.

For installations where this option is not possible, an experienced engineering decision must be made regarding the potential impact to thermal performance.

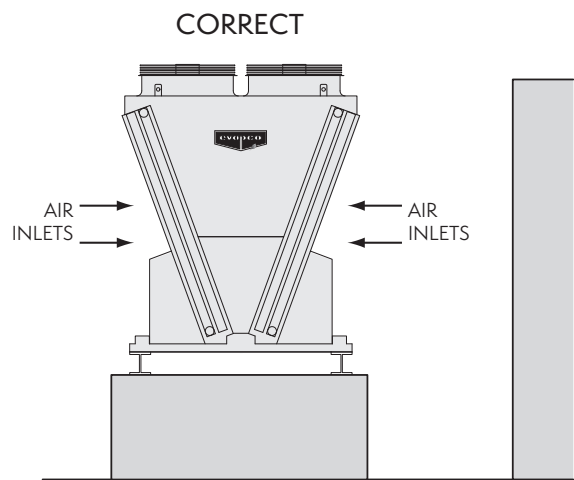
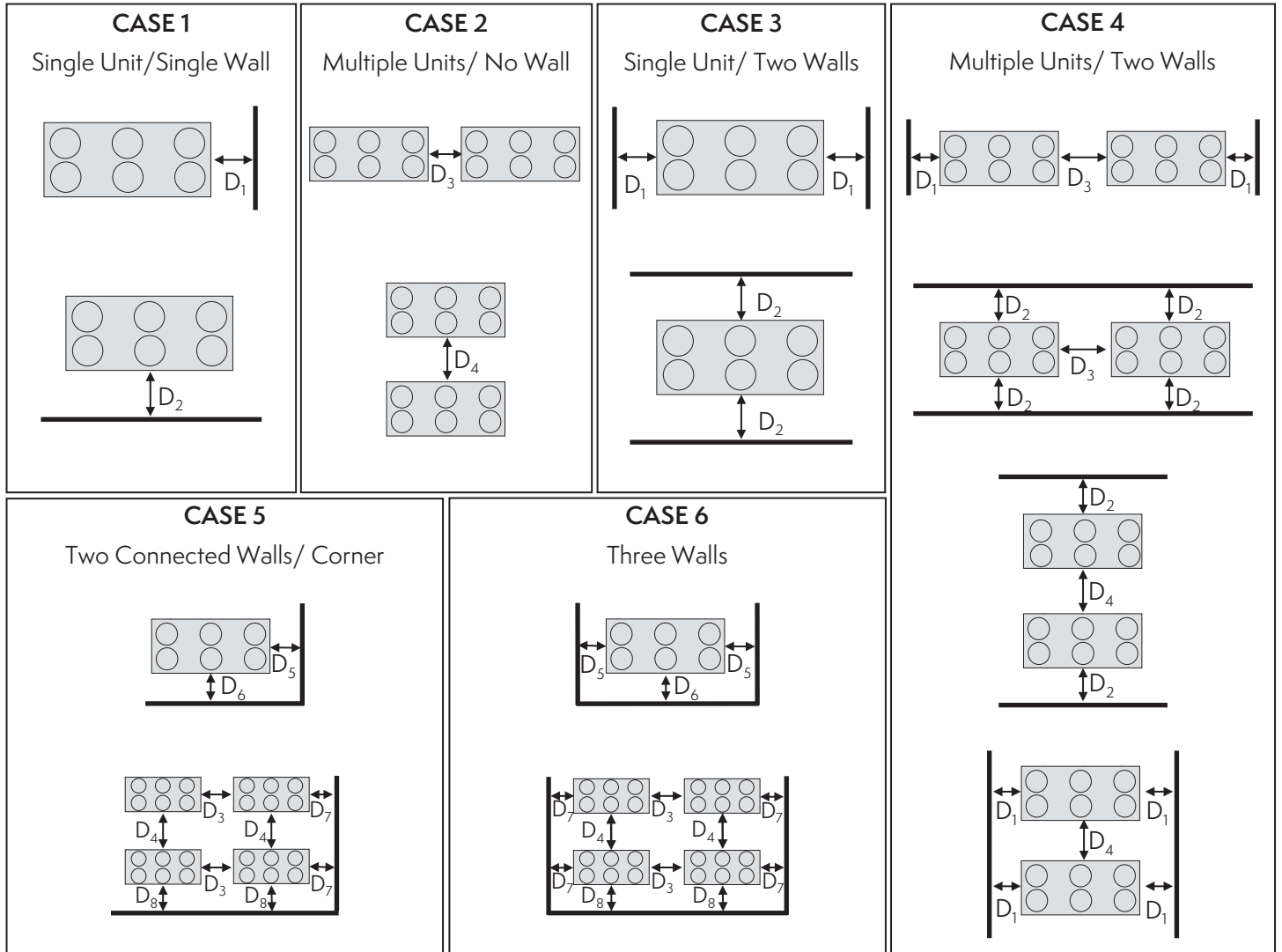

Figure 3 - Elevated Installation so Top of Unit is Level with or Higher than Adjacent Structure

Single & Multiple Unit Installations & Recommended Layout Clearances

Adequate clearances between eco-Air units and obstructions must be maintained to ensure that unit(s) have proper airflow and to minimize the possibility of recirculation. EVAPCO has developed recommended distances, D1 – D8 in Table 1, for various layouts shown in Cases 1-6 below.



Model Width	Length	Width	D1	D2	D3	D4	D5	D6	D7	D8	Dimension Key
Flat	All	6' (1.8m)	3' (0.9m)	3' (0.9m)	6' (1.8m)	6' (1.8m)	3' (0.9m)	3' (0.9m)	3' (0.9m)	3' (0.9m)	
Flat	All	7' & 8' (2.1m & 2.4m)	4' (1.2m)	4' (1.2m)	8' (2.4m)	8' (2.4m)	4' (1.2m)	4' (1.2m)	4' (1.2m)	4' (1.2m)	
V-Coil	Less than 10' (3m)	All	3' (0.9m)	3' (0.9m)	6' (1.8m)	6' (1.8m)	3' (0.9m)	3' (0.9m)	3' (0.9m)	3' (0.9m)	D2, D6 & D8- side to wall clearance
V-Coil	10' to 20' (3m to 3.6m)	All	3' (0.9m)	5' (1.5m)	6' (1.8m)	10' (3m)	3' (0.9m)	5' (1.5m)	3' (0.9m)	5' (1.5m)	
V-Coil	20' to 30' (3.6m to 9.1m)	All	3' (0.9m)	6' (1.8m)	6' (1.8m)	12' (3.6m)	3' (0.9m)	6' (1.8m)	3' (0.9m)	6' (1.8m)	D3- end to end clearance
V-Coil	30' to 40' (9.1m to 12m)	All	3' (0.9m)	7' (2.1m)	6' (1.8m)	14' (4.2m)	3' (0.9m)	7' (2.1m)	3' (0.9m)	7' (2.1m)	
Double Stack	13' (4m)	All	4' (1.2m)	5' (1.5m)	8' (2.4m)	10' (3m)	4' (1.2m)	5' (1.5m)	4' (1.2m)	5' (1.5m)	D4- side to side clearance
Double Stack	26' (7.9m)	All	4' (1.2m)	8' (2.4m)	8' (2.4m)	16' (4.8m)	4' (1.2m)	8' (2.4m)	4' (1.2m)	8' (2.4m)	
Double Stack	39' (11m)	All	4' (1.2m)	10' (3m)	8' (2.4m)	20' (6m)	4' (1.2m)	10' (3m)	4' (1.2m)	10' (3m)	

Table 1 - EVAPCO's Recommended Clearances for Dry, Adiabatic and Spray Units, Dimensions D1 – D8

Large Installations

For large dry, adiabatic and spray unit installations that have four or more units, it is imperative that the unit layout be carefully examined during the design of the system. Very large multiple unit installations can create their own environment. Under certain weather and atmospheric conditions, the large quantity of discharge air will cause the dry bulb temperature in the immediate area to be higher than the local design data. The minimum dimensions shown in Table 1 should be increased whenever possible in order to allow for an additional safety factor. The potential increase in temperature is dependent on the number of units, type of installation, existing equipment, unit surroundings, and atmospheric conditions.

Locating a large installation in a valley or between buildings can change the surrounding environment by creating a higher dry bulb, which must be considered for layout and will not abide by the dimensions in Table 1. Prevailing winds must also be considered for these installations, specifically during the portion of the year with highest ambient temperatures.

Figure 4 shows EVAPCO's recommendation for unit layout relative to prevailing wind direction during the hottest part of the year. Consult your local EVAPCO representative for recommended layout guidelines for very large multiple unit installations.

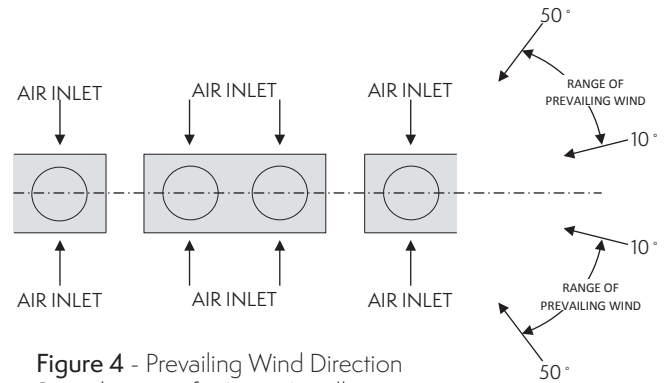

Figure 4 - Prevailing Wind Direction Considerations for Large Installations

Expansions to Existing Systems

Expansions to existing systems present the same concerns as multiple/large unit installations. However, there are additional concerns that must be evaluated when planning a system expansion. Since in an expansion the new unit may not be identical to the existing one, it is important to examine the heights of the new and the existing units.

Whenever possible, the tops of **ALL** of the units should be at the same level to avoid recirculation from one unit to another. If the unit discharge heights are different one or a combination of the following should be implemented.

Either structural steel should be used to raise the air discharges of both units to the same level as shown, or the units should be spaced further apart than normally recommended.

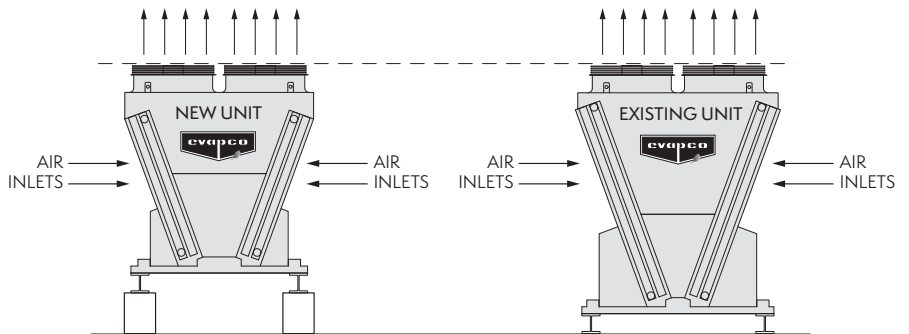

Figure 5 - Expansion into Existing System

Maintenance & Electrical Spacing Considerations

When a unit is located in close proximity to other structures, walls or equipment, there are minimum clearances required for periodic maintenance, piping connections, control panels or other obstructions. Unit drawings must be reviewed to ensure there is room for any future repair work. If the EVAPCO eco-Air unit is equipped with a factorywired enclosure, like a terminal box or control panel, local and national electrical codes must be consulted for adequate clearance requirements.

Enclosures & Wells

Solid Wall Enclosures & Wells

When units are placed in solid enclosures and wells, there are three main considerations to ensure the chance for hot air recirculation is minimized.

#1. Clearances The unit must follow clearance dimensions in Table 1 (page 4), and in many cases these dimensions must be increased when placed next to four solid walls. Accessory and electrical clearances must also be considered. The unit should also be oriented such that air can flow uniformly through on all four sides.

#2. Discharge Height To diminish any opportunity for recirculation, the air discharge must be at level or higher than the enclosure or well walls. See page 3 for more information on this.

#3. Downward Air Velocity The downward air velocity must be kept below 400 FPM (2m/s). Downward air velocity is the unit airflow divided by the usable well area, the space between the four sides of the unit and the walls (see the shaded portion of Figure 6). See the example calculation of the downward air velocity.

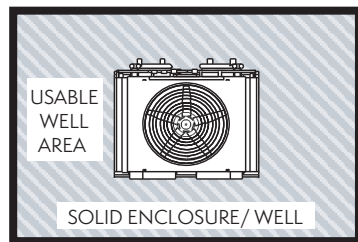

Figure 6 - Unit in Solid Enclosure

Example: A 7' x 7' (2.1m x 2.1m) EAW-VD is centered in a 20' x 24' (6m x 7.2m) well enclosure with the unit's discharge even with the top of the surrounding walls. Is this an acceptable equipment layout?

Unit & Enclosure Specifications:

Unit Area = 47.5 ft² (4.41m²),
 Unit Airflow = 40,060 CFM (18.9m³/s),
 Well Area = 465 ft² (43.2m²)

Recommended Minimum Clearances (from Table 1):

D1 = 3 ft (0.9m), D2 = 3 ft (0.9m)

Calculations:

Actual D1 = 24 ft - 7 ft/2 = **8.5 ft ✓**
 (7.2m - 2.1m/2) = **2.55m ✓**
 Actual D2 = 20 ft - 7 ft/2 = **6.5 ft ✓**
 (6m - 2.1m/2) = **1.95m ✓**

Net Usable Well Area = 465 ft² - 47.5 ft² = 417.5 ft²

(43.2m² - 4.41m² = 38.79m²)

Downward Velocity = 40,060 CFM ÷ 417.5 ft² = **95.9 FPM ✓**
 (18.9m³/s ÷ 38.79m²) = **0.487m/s ✓**

This example IS an acceptable layout with the given unit and enclosure specifications, as it meets all three recommendations.

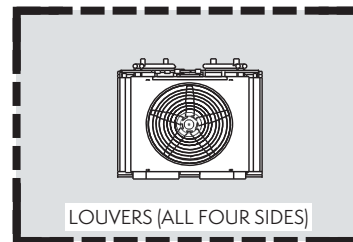

Figure 7 - Unit in Louvered Enclosure

Louvered Wall Enclosures

Dry, adiabatic and spray units can also be installed in enclosures with louvered or slotted walls (Figure 7). With this type of enclosure, the air flow patterns will be a mixture of the open type and well installations. The inlet air will be drawn from the top and through the louvers or slotted openings. Since the air will follow the path of least resistance, the pressure drop across the louvers will determine how much air is drawn through them. To minimize the potential for recirculation, it is better to draw most of the air through the louvers.

Therefore, it is important that the louvers are designed for minimum pressure drop. To achieve this goal, the velocity through the louvers should be maintained at or below 600 FPM (3m/s), the louvers should have a minimum of 50% net free area, and the air inlets should face the louvers.

The first step in checking a louvered type of enclosure is to treat it as a well enclosure and calculate the downward air velocity assuming that all the air must enter from the top. If the downward air velocity is equal to or less than 400 FPM (2m/s), then the louvered enclosure will work regardless of the size of the louvers.

If the downward air velocity into the enclosure is greater than 400 FPM (2m/s), then another formula must be used. This formula assumes that ALL the air is drawn through the louvers. The total air flow [CFM (m³/s)] for the unit is divided by the net free louver area [ft²(m²)]. The resultant air velocity must be below 600 FPM (3m/s). In addition to meeting this minimum louver velocity, the minimum air inlet to louver dimension must be 3 feet (0.9m) and the layout must meet the minimum space requirements for maintenance and unit accessories.

Flat Models

Flat models can be elevated for those layouts where they must be placed closer together than EVAPCO's recommended guidelines. In Figure 8, the Z is elevation distance beyond standard leg height.

Elevation (Z)		0 (0m)	0.5' (0.15m)	1' (0.3m)	2' (0.6m)	≥ 4' (1.2m)	
Spacing (Y)	Unit Width	6' (1.8m)	6' (1.8m)	6' (1.8m)	4' (1.2m)	2' (0.6m)	0' (0m)
		7' & 8' (2.1m & 2.4m)	8' (2.4m)	6' (1.8m)	4' (1.2m)	2' (0.6m)	0' (0m)

Table 2 - Flat Model Elevation and Spacing Measurements

For example, if a flat unit is raised 2' (0.6m) [Z=2' (0.6m)], then only 2' (0.6m) [Y=2' (0.6m)] of side to side clearance is needed instead of 8' (2.4m) per Table 1.

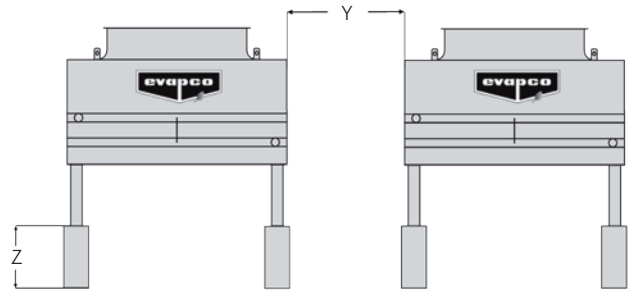

Figure 8 - Flat Model Elevation and Spacing Measurements Positions

V-Coil Models

V-Coil models can be elevated for those layouts where they must be placed closer together than this manual allows. The chart below shows spacing in elevated unit installations. See notes at bottom regarding adiabatic units and large unit layouts.

Elevation (Z)		0' (0m)	2' (0.6m)	4' (1.2m)	6' (1.8m)	8' (2.4m)	≥ 10' (3m)	
Spacing (Y)	Unit Width	Less than 10' (3m)	6' (1.8m)	4' (1.2m)	3' (0.9m)	2.5' (0.75m)	2' (0.6m)	
		10' to 20' (3m to 6m)	10' (3m)	8.5' (2.55m)	7.5' (2.25m)	6.5' (1.95m)	6' (1.8m)	5' (1.5m)
		20' to 30' (6m to 9m)	12' (3.6m)	10.5' (3.15m)	9.5' (2.85m)	8.5' (2.55m)	8' (2.4m)	7' (2.1m)
		30' to 40' (9.1m to 12m)	14' (4.2m)	13' (3.9m)	12' (3.6m)	11' (3.3m)	10' (3m)	9.5' (2.85m)

Table 3 - V-Coil Model Elevation and Spacing Measurements

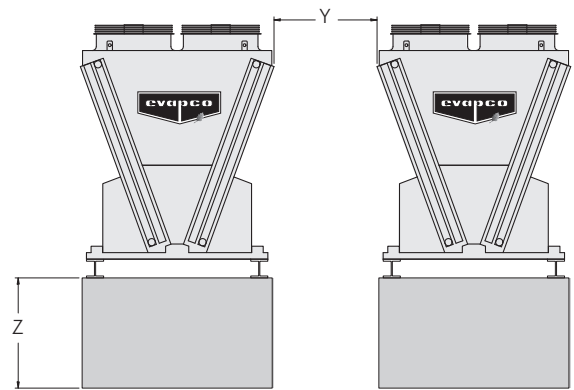

Figure 9 - V-Coil & Double Stack Model Elevation and Spacing Positions

Double Stack Models

See the following chart for spacing in elevated Double Stack unit installations.

Elevation (Z)		0' (0m)	2' (0.6m)	4' (1.2m)	6' (1.8m)	8' (2.4m)	≥ 10' (3m)	
Spacing (Y)	Unit Width	13' (3.9m)	10' (3m)	7.5' (2.25m)	6.5' (1.95m)	6' (1.8m)	5' (1.5m)	4.5' (1.35m)
		26' (7.8m)	16' (4.8m)	14' (4.2m)	13' (3.9m)	12' (3.6m)	11' (3.4m)	10' (3m)
		39' (11.7m)	20' (6m)	19' (5.7m)	18' (5.4m)	16.5' (4.95m)	15.5' (4.65m)	15' (4.5m)

Table 4 - Double Stack Model Elevation and Spacing Measurements

Adiabatic eco-Air units can be elevated, but grade level layout guidelines apply. They cannot be elevated in lieu of spacing. This also applies to any dry cooler or condenser that would be retrofitted with adiabatic pad systems.

Large unit layouts won't necessarily see the same benefits from elevation. If you have any questions about layout scenarios not covered by this manual, please contact your local EVAPCO Sales Representative for confirmation of layout design.



WORLDWIDE MANUFACTURING FACILITIES



- World Headquarters/ Research and Development Center
- EVAPCO Manufacturing Facilities

EVAPCO, Inc. — World Headquarters & Research/Development Center

P.O. Box 1300 • Westminster, MD 21158 USA
410.756.2600 • marketing@evapco.com • evapco.com

North America

- EVAPCO, Inc. World Headquarters**
Westminster, MD USA
410.756.2600
marketing@evapco.com
- EVAPCO East**
Taneytown, MD USA
- EVAPCO East**
Key Building
Taneytown, MD USA
- EVAPCO Midwest**
Greenup, IL USA
217.923.3431
evapcomw@evapcomw.com
- Evapcold Manufacturing**
Greenup, IL USA
- EVAPCO Newton**
Newton, IL USA
618.783.3433
evapcomw@evapcomw.com
- EVAPCO West**
Madera, CA USA
559.673.2207
contact@evapcowest.com
- EVAPCO Alcoil, Inc.**
York, PA USA
717.347.7500
info@evapco-alcoil.com
- EVAPCO Iowa**
Lake View, IA USA
- EVAPCO Iowa**
Sales & Engineering
Medford, MN USA
507.446.8005
evapcomn@evapcomn.com
- EVAPCO LMP ULC**
Laval, Quebec, Canada
450.629.9864
info@evapcolmp.ca
- EVAPCO Select Technologies, Inc.**
Belmont, MI USA
844.785.9506
emarketing@evapcoselect.com
- Refrigeration Vessels & Systems Corporation**
Bryan, TX USA
979.778.0095
rvs@rvscorp.com
- Tower Components, Inc.**
Ramseur, NC USA
336.824.2102
mail@towercomponentsinc.com
- EvapTech, Inc.**
Edwardsville, KS USA
913.322.5165
marketing@evaptech.com
- EVAPCO Dry Cooling, Inc.**
Bridgewater, NJ USA
908.379.2665
info@evapcodc.com
- EVAPCO Dry Cooling, Inc.**
Littleton, CO USA
908.895.3236
info@evapcodc.com
- EVAPCO Power México S. de R.L. de C.V.**
Mexico City, Mexico
[52] 55.8421.9260
info@evapcodc.com

Asia Pacific

- EVAPCO Asia Pacific Headquarters**
Baoshan Industrial Zone Shanghai, P.R. China
[86] 21.6687.7786
marketing@evapcochina.com
- EVAPCO (Shanghai) Refrigeration Equipment Co., Ltd.**
Baoshan Industrial Zone, Shanghai, P.R. China
- EVAPCO (Beijing) Refrigeration Equipment Co., Ltd.**
Huairou District, Beijing, P.R. China
[86] 10.6166.7238
marketing@evapcochina.com
- EVAPCO Air Cooling Systems (Jiangxi) Company, Ltd.**
Jiaxing, Zhejiang, P.R. China
[86] 573.8311.9379
info@evapcochina.com
- EVAPCO Australia (Pty.) Ltd.**
Riverstone, NSW, Australia
[61] 02.9627.3322
sales@evapco.com.au
- EvapTech (Shanghai) Cooling Tower Co., Ltd.**
Baoshan District, Shanghai, P.R. China
Tel: [86] 21.6478.0265
- EvapTech Asia Pacific Sdn. Bhd.**
Puchong, Selangor, Malaysia
[60] 3.8070.7255
marketing-ap@evaptech.com

Europe | Middle East | Africa

- EVAPCO Europe EMENA Headquarters**
Tongerren, Belgium
[32] 12.39.50.29
info@evapco.be
- EVAPCO Europe BV**
Tongerren, Belgium
- EVAPCO Europe, S.r.l.**
Milan, Italy
[39] 02.939.9041
evapcoeuropa@evapco.it
- EVAPCO Europe, S.r.l.**
Sondrio, Italy
- EVAPCO Europe A/S**
Aabybro, Denmark
[45] 9824.4999
info@evapco.dk
- EVAPCO Europe GmbH**
Meerbusch, Germany
[49] 2159.69560
info@evapco.de
- EVAPCO Middle East DMCC**
Dubai, United Arab Emirates
[971] 56.991.6584
info@evapco.ae
- Evap Egypt Engineering Industries Co.**
A licensed manufacturer of EVAPCO, Inc.
Nasr City, Cairo, Egypt
[20] 10.054.32198
evapco@tiba-group.com
- EVAPCO S.A. (Pty.) Ltd.**
A licensed manufacturer of EVAPCO, Inc.
Isando, South Africa
[27] 11.392.6630
evapco@evapco.co.za

South America

- EVAPCO Brasil**
Equipamentos Industriais Ltda.
Indaiatuba, São Paulo, Brazil
[55] 11.5681.2000
vendas@evapco.com.br
- FanTR Technology Resources**
Itu, São Paulo, Brazil
[55] 11.4025.1670
fantr@fantr.com