



ATC-E

EVAPORATIVE CONDENSERS



CROSSCOOL
Technology

ADVANCED **T**ECHNOLOGY IN
INDUCED DRAFT, AXIAL FAN CONDENSERS
215 till 16000 kW nominal capacity

DELIVERING QUALITY... FOCUSED ON PERFECTION!

CERTIFIED EN ISO 9001



IARW International Association of Refrigerated Warehouses



ATC-E DESIGN AND CONSTRUCTION FEATURES

The ATC line of evaporative condensers reflects EVAPCO's commitment to product development. Their advanced design provides owners with many operational and performance advantages.

These induced draft, counterflow condensers are designed for easy maintenance and long, trouble-free operation.

Easy to Service Motor Mount Design

- All normal maintenance can be performed quickly from outside the unit
- Designed for easy belt adjustment
- Extended lube lines for easy bearing lubrication
- If required, motor may swing to outside for easy removal



Water Saver Drift Eliminators

- New patented design reduces drift rate to < 0.001%
- Saves water and reduces water treatment cost
- Greater structural integrity vs. old style blade-type
- Recessed into casing for greater protection
- Drift rate certifications Eurovent OM-14-2009



PVC Spray Distribution Header with ZM II™ Nozzles

- Large orifice nozzles prevent clogging (no moving parts)
- Nozzles are threaded into header at proper orientation
- Fixed position nozzles require zero maintenance
- Guaranteed for life



Totally Enclosed Pump Motors

- Help assure long, trouble-free operation

Stainless Steel Strainers

- Resists corrosion better than other materials



Z-725 Heavy Mill Hot-Dip Galvanized Steel Construction

(Stainless steel available as affordable option)



Since its founding in 1976, EVAPCO, Inc. has become a world-wide leader in supplying quality cooling equipment for thousands of customers in both the commercial and industrial markets.

EVAPCO's success has been the result of a continual commitment to product improvement, quality workmanship and a dedication to providing unparalleled service.



Our emphasis on research and development has led to many product innovations – a hallmark of EVAPCO through the years.

The ongoing R & D Program enables EVAPCO to provide the most advanced products in the industry – technology for the future, available today.

EVAPCO products are manufactured on five continents around the world and distributed through hundreds of factory authorized sales representatives.

Advanced Design Smooth Flow Fans

- Totally Enclosed Fan Motors assures long life
- Power-Band Belts for Better Lateral Rigidity
- Advanced Design Aluminum Fan Blades
- Non-corroding Cast Aluminum Sheaves
- Heavy-Duty Fan Shaft Bearings with L-10 life of 75000 - 135000 hrs
- All Other Components Corrosion Resistant Materials

Low Sound Options available
Refer to page 11



Super Low Sound Fan (optional)

- Extremely wide sloped fan blades for sound sensitive applications
- One piece molded heavy duty construction
- 9-15 dB(A) sound reduction

Patented Thermal-Pak® Coil Design
Features EVAPCO's exclusive CROSScool™

EVAPCO'S Thermal-Pak® II condensing coils now features exclusive **CROSScool™** tube enhancement for greater internal heat transfer. This unique coil design utilizes counterflow heat transfer. The rows of elliptical tubes are staggered and angled in the direction of airflow to enhance air turbulence, thereby increasing heat transfer while minimizing airside pressure drop. The design features of EVAPCO'S Thermal-Pak® II condensing coils ensure the end user will receive the best evaporative heat transfer efficiency. These characteristics and other engineering advancements of the Thermal-Pak® II have been proven in EVAPCO'S world-class research and development laboratory resulting in the following end user benefits:

- Lower Operating Refrigerant Charge
- Low Power Consumption
- Lower Operating Weight
- Small Plan Area

The coils are manufactured from high quality internally enhanced **CROSScool™** carbon steel tubing following the most stringent quality control procedures. Each circuit is inspected to assure the material quality and then tested before being assembled into a coil. Finally, the assembled coil is tested in accordance with the "Pressure Equipment Directive" (PED) 97/23/EC.

To protect the coil against corrosion, it is placed in a heavy-duty steel frame and the entire assembly is dipped in molten zinc (hot dip galvanized) at a temperature of approximately 430°C.

IBC Compliant Design
Refer to page 17

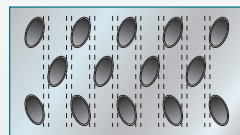

Thermal-Pak® Coil by EVAPCO

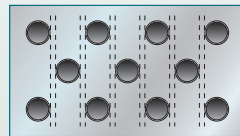

Round Tube Coil by Others



"Clean Pan" Basin Design

- Access from all four sides
- Large open area simplifies maintenance
- Basin may be inspected with pumps running
- Sloped basin design prevents sediment buildup, biological film and standing water
- Optional: full stainless steel welded basin

WST Air Inlet Louvers (Water and Sight Tight)

- Easily removable for access
 - Patented design keeps sunlight out—preventing biological growth
 - Keeps water in while keeping dirt and debris out
- U.S. Patent No. 7927196



Louver Access Door

- Hinged access panel with quick release mechanism
- Allows easy access to perform routine maintenance and inspection of the make-up assembly, strainer screen and basin
- Available on larger models



Easy Field Assembly

- A new field assembly seam design which ensures easier assembly and reduced potential for field seam leaks
- Self-guided channels guide the fan casing section into position improving the quality of the field seam
- Eliminates up to 66% of fasteners



ATC-E

DESIGN FEATURES

EVAPCOAT Corrosion Protection System

EVAPCO, long known for using premium materials of construction, has developed the ultimate system for corrosion protection in galvanized steel construction – the EVAPCOAT Corrosion Protection System. Marrying corrosion free materials with heavy gauge mill hot-dip galvanized steel construction to provide the longest life product with the best value.

The Evapcoat Corrosion Protection System consist of:

- **Z-725 Mill Hot-Dip Galvanized Steel Construction**

Mill hot-dip galvanized steel has been successfully used for over 25 years for the protection of evaporative condensers against corrosion. There are various grades of mill galvanized steel each with differing amounts of zinc protection. EVAPCO has been a leader in the industry in developing heavier galvanizing, and was the first to standardize on Z-600 mill hot-dip galvanized steel. Now, EVAPCO is, once again, increasing the level of corrosion protection by being the first and only manufacturer in Europe to use Z-725 mill hot-dip galvanized steel.

Z-725 designation means there is a minimum of 725 g of zinc per m² of surface area present on the steel. Z-725 is the heaviest level of galvanizing available for manufacturing evaporative condensers and has over 2.5 times more zinc protection than competitive designs using Z-275 steel. With Z-725 mill hot-dip galvanized steel construction, EVAPCO provides galvanized steel panels with corrosion protection that approaches the level of the hot-dip galvanized heat exchanger coils.

During fabrication, all panel edges are coated with a 95% pure zinc-rich compound for extended corrosion resistance.

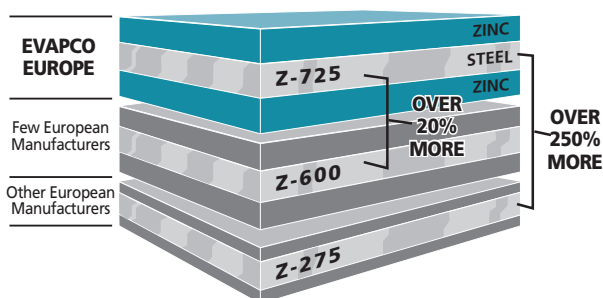

- **Type 304 Stainless Steel Strainers**

Subjected to excessive wear and corrosion, the sump strainer is critical to the successful operation of the condenser. EVAPCO uses only stainless steel for this very important component.

- **PVC Air Inlet Louvers**

The innovative design uses corrosion free materials while effectively eliminating splash out and reducing the potential for algae formation inside the condenser.

- **PVC Drift Eliminators**

The final elements in the upper part of the condenser are moisture eliminators which strip the entrained water droplets from the leaving air stream.

EVAPCO eliminators are constructed entirely of inert, corrosion-free PVC. This PVC material has been specially treated to resist damaging ultraviolet light. The eliminators are assembled in easily handled sections to facilitate removal thereby exposing the upper portion of the unit and water distribution system for periodic inspection.

- **PVC Water Distribution System, ZM II™ Spray Nozzle**

The fixed position ZM II™ Spray Nozzles are mounted in corrosion-free PVC water distribution pipes. Together, these elements combine to provide unequaled coil coverage, scale prevention and make the industries best performing non-corrosive, maintenance-free water distribution system.

- **Totally Enclosed Motors**

EVAPCO uses totally enclosed motors for all fan and pump motors as standard. These superior motors help to assure longer equipment life without motor failures, which result in costly downtime.

- **Alternate Materials of Construction**

EVAPCO induced draft condensers have a modular design which allows for specific areas to be enhanced for increased corrosion protection. For particularly corrosive environments, EVAPCO condensers are available with Stainless Steel construction for the basin, casing and/or coil.

- **Stainless Steel Basin - welded execution**

The basin area of a condenser is often subjected to high concentrations of impurities and silt. In addition to the EVAPCOAT Corrosion Protection System, EVAPCO offers optional **welded** stainless steel construction for superior corrosion resistance. This option provides Type 304 or Type 316 stainless steel for the entire basin section - including the support columns and air inlet louver frames.

- **Stainless Steel Coils**

The heat exchanger coil is the heart of the evaporative condenser. For this critical component, EVAPCO offers the options of Type 304 or type 316 stainless steel construction.

DESIGN FEATURES

ATC-E

Axial Fan Drive System Direct Drive Units – 1.2 m Wide Models

ATC 50E to ATC 165E

The T.E.F.C. motors are located on the outside of the unit and are protected by a hinged cover.



External Motor Mount

Belt Drive Units – 2.3 m and 2.4 m Wide Models

ATC M170E to ATC M844E

The fan motor and drive assembly on these units are designed to allow easy servicing of the motor and adjustment of the belt tension from the exterior of the unit. The T.E.F.C. fan motor is mounted on the outside of these models.



External Motor Mount (with optional ladder)

A large hinged access door with a "quick release" latch provide access to the fan section for maintenance.

Belt Drive Units – 3 m & 3.6 m Wide Models

ATC XE298E to ATC XC1340E - ATC 428E to ATC 3714E

Designed as the ideal replacement condenser, these models provide both cost effective and energy efficient alternatives to obsolete centrifugal fan designs. The 3 m wide plan areas are also well suited for new installations and provide more layout flexibility. The unique belt drive design features are detailed below.



Motor Base Assembly

The fan motor and drive assembly is designed to allow easy servicing of the motor and adjustment of the belt tension from the exterior of the unit. The T.E.A.O. fan motor is located inside the fan casing on a rugged heavy duty motor base. The innovative motor base also features a unique locking mechanism for a positive adjustment.

The motor base is designed to swing out through a very large 1.3 m² access opening. This allows for easy servicing of the motor.



Motor Access

Power- Band Drive Belt: The Power-Band is a solid-back, multigroove belt system that has high lateral rigidity. The belt is constructed of neoprene with polyester cords. The drive belt is designed for 150 percent of the motor nameplate kW for long life and durability.

Fan Shaft Bearings: The fan shaft bearings in ATC units are specially selected for long, trouble-free life. They are rated for an L-10 life of 75,000 to 135,000 hours and are the heaviest pillow block bearings available.

Aluminum Alloy Pulleys: Fan pulleys are constructed of corrosion free aluminum for long life. The aluminum also helps belts last longer.

ATC-E

DESIGN FEATURES

Water Management High Efficient Water Saver Drift Eliminators

An extremely efficient drift eliminator system is standard on EVAPCO condensers. The patented system removes entrained water droplets from the air stream to limit the drift rate to less than 0.001% of the recirculating water rate. With a low drift rate, EVAPCO condensers save valuable water and water treatment chemicals. The drift eliminators are constructed of an inert polyvinyl chloride (PVC) plastic material which effectively eliminates corrosion of these vital components. They are assembled in sections to facilitate easy removal for inspection of the water distribution system.



Superior WST Air Inlet Louver and Screen Design

EVAPCO's patented WST Inlet Louvers keep water in and sunlight out of the basins of induced draft products. The unique non-planar design is made from light-weight PVC sections which easily fit together and have no loose hardware, enabling easy basin access.

Developed with computational fluid dynamics (CFD) software, the louver's air channels are optimized to maintain fluid dynamic and thermodynamic efficiency and block all line-of-sight paths into the basin eliminating splash-out; even when the fans are off. Additionally, algae growth is minimized by blocking all sunlight.

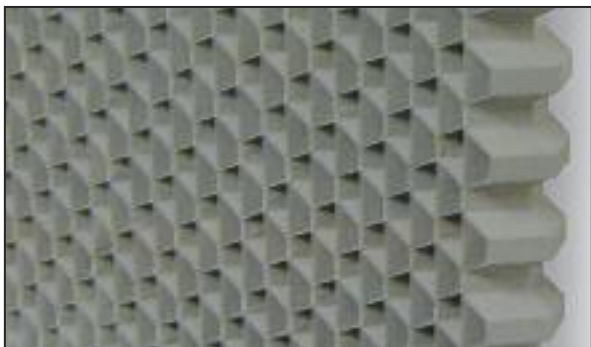

Inlet Louver Material

The combination of easy basin access, no splash-out and minimized algae growth saves the end user money on maintenance hours, water consumption and water treatment costs.

"Clean Pan" Basin Design

EVAPCO condensers features a completely sloped basin from the upper to lower pan section. This "Clean Pan" design allows the water to be completely drained from the basin. The water will drain from the upper section to the depressed lower basin section where the dirt and debris can be easily flushed out through the drain. This design helps prevent buildup of sedimentary deposits, biological films and minimizes standing water.

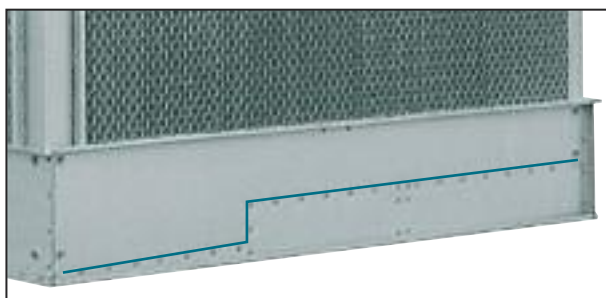

Sloped Basin

ZM II™ Spray Nozzle Water Distribution System

Even and constant water distribution is paramount for reliable, scale-free evaporative cooling. EVAPCO's Zero Maintenance ZM II™ Spray Nozzle, mounted in a PVC distribution pipe remains clog-free under the toughest conditions to deliver approximately 4 l/s to every square meter of coil plan area.

The heavy-duty nylon ZM II™ Spray nozzles have a 33 mm diameter opening and a 38 mm splash plate clearance, enabling EVAPCO to use 75% fewer nozzles.



ZM II™ Nozzle

OPTIONAL EQUIPMENT

ATC-E

Two Speed Motors

Two speed fan motors can provide an excellent means of capacity control. In periods of lightened loads or reduced wet bulb temperatures, the fans can operate at low speed, which will provide about 60% of full speed capacity, yet consume only about 15% of the power compared with high speed. In addition to the energy savings, the sound levels of the units will be greatly reduced at low speed.

Inverter Duty Motors

Inverter Duty motors are available for condenser applications which utilize variable frequency drive systems for capacity control. Inverter Duty motors offer totally enclosed premium efficiency construction which is designed for variable frequency drive applications.

Note: Other special motor configurations are available to meet specific proper requirements. Contact your local EVAPCO sales representative for application assistance and motor availability.

Remote Sump Configuration

For units operating in areas where temperatures may be very low, or where low temperatures may occur during periods when the unit is not operating, a sump located inside the building is the preferred means of ensuring that the basin water will not freeze. For these applications, the condenser will be supplied without the spray pump, suction strainers and all associated piping, but with an oversize bottom outlet.

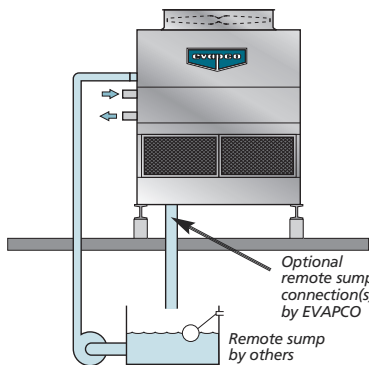

Dual Fan Option

Evapco now offers a Dual Fan arrangement on 10x18, 12x18 and 12x20 nominal box sizes.

The Dual Fan option gives users redundancy in large box sizes by providing independent motors, fans, and drives that previously only had a single fan and motor.



Basin Heater Package

If a remote sump configuration is not practical, electric basin heater packages are available to help prevent freeze-up of the basin water. The packages include electric heater elements and a combination with thermostat and low water cut-off. (Consult EVAPCO for heater size and application)

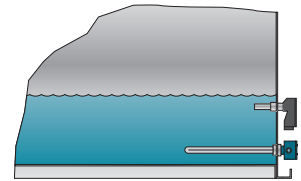

Electric Water Level Control

Evaporative condensers may be ordered with an electric water level control in lieu of the standard mechanical float and make-up assembly. This package provides accurate control of water levels and does not require field adjustment.

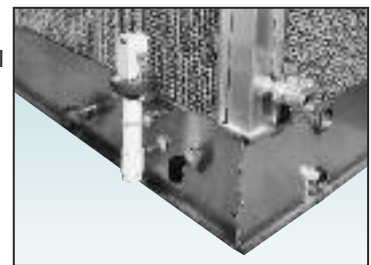

Multiple Circuit Coils

Condensers may be supplied with multiple circuit coils to match various system requirements such as split systems.

Self Supporting Service Platforms

Condensers are available with self-supporting service platforms that include access ladders which are designed for easy field installation. This option offers significant savings in comparison to field constructed, externally supported catwalks. The EVAPCO service platform option will be installed in front of the fan access doors.

Motor Davit

In the event that a fan and/or fan motor should need to be replaced, a motor davit is available from which a chain fall can be mounted to easily lower the motor/fan to the ground.



ATC Condenser with Optional Service Platform and Motor Davit

OPTIONS

ATC-E

APPLICATION

Design

Evapco units are of heavy-duty construction and designed for long trouble-free operation. Proper equipment selection, installation and maintenance is, however, necessary to ensure full unit performance. Some of the major considerations in the application of a cooler are presented below. For additional information, please contact the factory.

Air Circulation

It is important that proper air circulation be provided. The best location is on an unobstructed roof top or on ground level away from walls and other barriers. Those condensers located in wells, enclosures or adjacent to high walls must be properly located to avoid the problems associated with recirculation.

Recirculation raises the wet bulb temperature of the entering air causing the water temperature to rise above the design. For these cases, the discharge of the fan should be located at a height even with the adjacent wall, thereby reducing the chance of recirculation. For additional information, see the Evapco Equipment Layout Manual. Good engineering practice dictates that the condenser discharge air not be directed or located close to or in the vicinity of building air intakes.

Recirculating Water System

The surest way to protect the recirculating water system from freezing is with a remote sump. The remote sump should be located inside the building and below the unit. When a remote sump arrangement is selected, the spray pump is provided by others and installed at the remote sump. All water in the condenser basin should drain to the remote sump when the spray pump cycles off. Other freeze protection methods are available when a remote sump is not feasible. Electric pan heaters can be used to keep the pan water from freezing when the unit cycles off. Water lines to and from the unit, spray pump and related piping should be heat traced and insulated up to the overflow level in order to protect from freezing. The unit should not be operated dry (fans on, pump off) unless the basin is completely drained and the unit has been designed for dry operation. Consult the factory when dry operation is a requirement.

Maintaining the Recirculated Water System

The heat rejection in a condenser is accomplished by the evaporation of a portion of the recirculated spray water. As this water evaporates, it leaves behind all of its mineral content and impurities. Therefore, it is important to bleed-off an amount of water equal to that which is evaporated to prevent the build-up of these impurities. If this is not done, the mineral or the acidic nature of the water will continue to increase. This will ultimately result in heavy scaling or a corrosive condition.

Bleed-off

Each unit supplied with a pump mounted on the side is furnished with a clear bleed line for visual inspection and a valve which, when fully open, will bleed-off the proper amount of water. If the make-up water supplying to the unit is relatively free of impurities, it may be possible to cut back the bleed, but the unit must be checked frequently to make sure scale is not forming. Make-up water pressure should be maintained between 140 and 340 kPa.

Water Treatment

In some cases the make-up water will be so high in mineral content that a normal bleed-off will not prevent scaling. In this case, water treatment will be required and a reputable water treatment company familiar with the local water conditions should be consulted.

Units constructed of galvanized steel operating with circulating water having a pH of 8,3 or higher will require periodic passivation of the galvanized steel to prevent the formation of "white rust".

Any chemical water treatment used must be compatible with the galvanized construction of the unit. If acid is used for treatment, it should be accurately metered and the concentration properly controlled. The pH of the water should be maintained between 7 and 8,8. Batch chemical feeding is not recommended because it does not afford the proper degree of control. If acid cleaning is required, extreme caution must be exercised and only inhibited acids recommended for use with galvanized construction should be used.

Control of Biological Contamination

Water quality should be checked regularly for biological contamination. If biological contamination is detected, a more aggressive water treatment and mechanical cleaning program is required. The water treatment program should be performed in accordance with local legislation and in conjunction with a qualified water treatment company.

It is important that all internal surfaces be kept clean of accumulated dirt or sludge. In addition, the drift eliminators should be kept in good operating condition to minimize water from exiting the condenser unit in the discharge air. To minimize the risk of biological contamination, at initial start up or after an extended shut down, it is recommended that the condenser be properly treated. Clean all debris such as leaves and dirt from the unit. Completely fill the basin to the overflow level with fresh water. Initiate a biocide water treatment or shock treatment program prior to operating the unit. It is preferable that all such procedures be conducted or supervised by a water treatment specialist.

APPLICATION

ATC-E

Piping

Evaporative condensers are used in refrigeration systems as an efficient means of heat rejection. Their installation and specifically the installation of the piping to and from the evaporative condenser has a direct effect on their operation and the overall energy efficiency of the refrigeration system. In this manual, we will explore the principles of piping evaporative condensers, beginning with single condensers and exploring multiple condenser installations as well as thermosiphon and sub-cooling piping systems.

Background

Evaporative condensers came into common use for nearly all refrigeration systems because of their operating advantages over the combination of cooling towers and condensers. They, of course, have also replaced the old "once through" water cooled condensing systems which are obsolete today because of the restrictions on the unlimited use of water coupled with its high cost.

Although, shell and tube condensing systems performed the same job of condensing the hot discharge gas into a saturated liquid as evaporative condensers; a small difference in the operating characteristics, namely pressure drop, requires some modification in the refrigerant piping hookup to and from the evaporative condenser. These changes are particularly important when dealing with multiple unit installations. In order to understand why the piping hookup is important, let's first take a brief look at the basic design differences of the two types of condensers to see why there is a difference in the pressure drop characteristics.

TYPICAL SHELL AND TUBE WATER COOLED CONDENSER

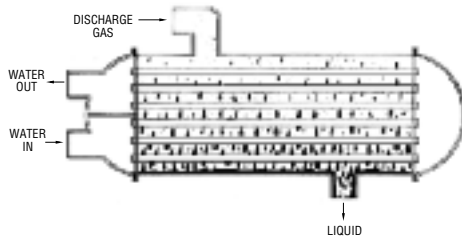

Figure 1

The shell type refrigerant condensers allow the refrigerant to flow around and condense on the outside of the water tubes. (See Figure 1) The refrigerant flow is almost entirely unimpeded resulting in a very low or nearly zero pressure drop through the condenser.

TYPICAL EVAPORATIVE CONDENSER COIL

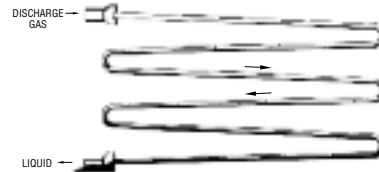
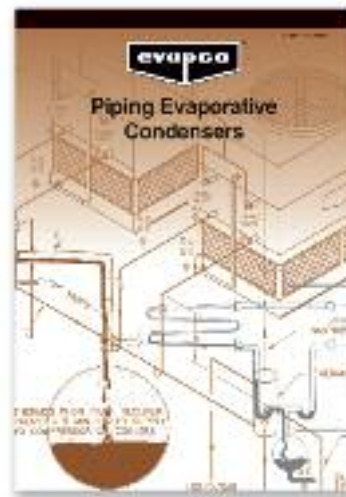

Figure 2

Contrasting, most evaporative condensers (See Figure 2) utilize some type of serpentine coil design where the hot refrigerant gas enters the top of the coil traveling back and forth through several rows as it is cooled and changed from a hot superheated gas to a saturated liquid. This longer travel path generally produces a small pressure drop which, though insignificant to the overall operation of the refrigeration system, does require proper attention be given to the condenser piping. Most of this attention needs to be focused on the liquid drain line from the outlet of the evaporative condenser to the high pressure receiver. The reason for this is described in the "Piping Brochure".

Piping Brochure

For additional information refer to EVAPCO Bulletin 131-E "Piping Evaporative Condensers" or consult your nearest Representative.



Technical Support Services

EVAPCO's evapselect™ Equipment Selection Program

EvapSelect™ is a web based computer selection program which allows the design engineer to choose EVAPCO models and optimize unit selections. The program allows the engineer to evaluate the equipment's thermal performance, space, energy requirements and water consumption. Once the model is selected and optional equipment features are inserted, the engineer may output a complete specification AND a unit drawing from this program.

The software is designed to provide the user with maximum flexibility in analyzing the various selection parameters while in a friendly and familiar Windows format.

The EvapSelect™ software is available to all consulting engineering offices and design-build contractors. The programs are distributed through the local EVAPCO sales representative or the EVAPCO offices.

EVAPCO's Website

Log on to EVAPCO's new and improved website <http://www.evapco.eu> for expanded product information. Product literature, Rigging and Maintenance Instructions are all accessible online from your computer.

The EvapSelect™ Equipment Selection Software program may be accessed using Microsoft Internet Explorer after contacting your local EVAPCO sales representative.

Users may make Requests for Quotation through the website or by e-mailing EVAPCO at this address: evapco.europe@evapco.eu

With the EvapSelect™ program, equipment selections, written specifications, unit drawing files and EVAPCO on-line information are readily available from the comfort of your own office!

ATC-E

Notes:

ATC-E

Ultra Quiet Evaporative Condensers



The ATC Evaporative Condenser is now available with three (3) equipment options to reduce the overall sound generated from the side or top of the ATC-E Evaporative Condenser.

Each option provides various levels of sound reduction and can be used in combination to provide the lowest sound level.

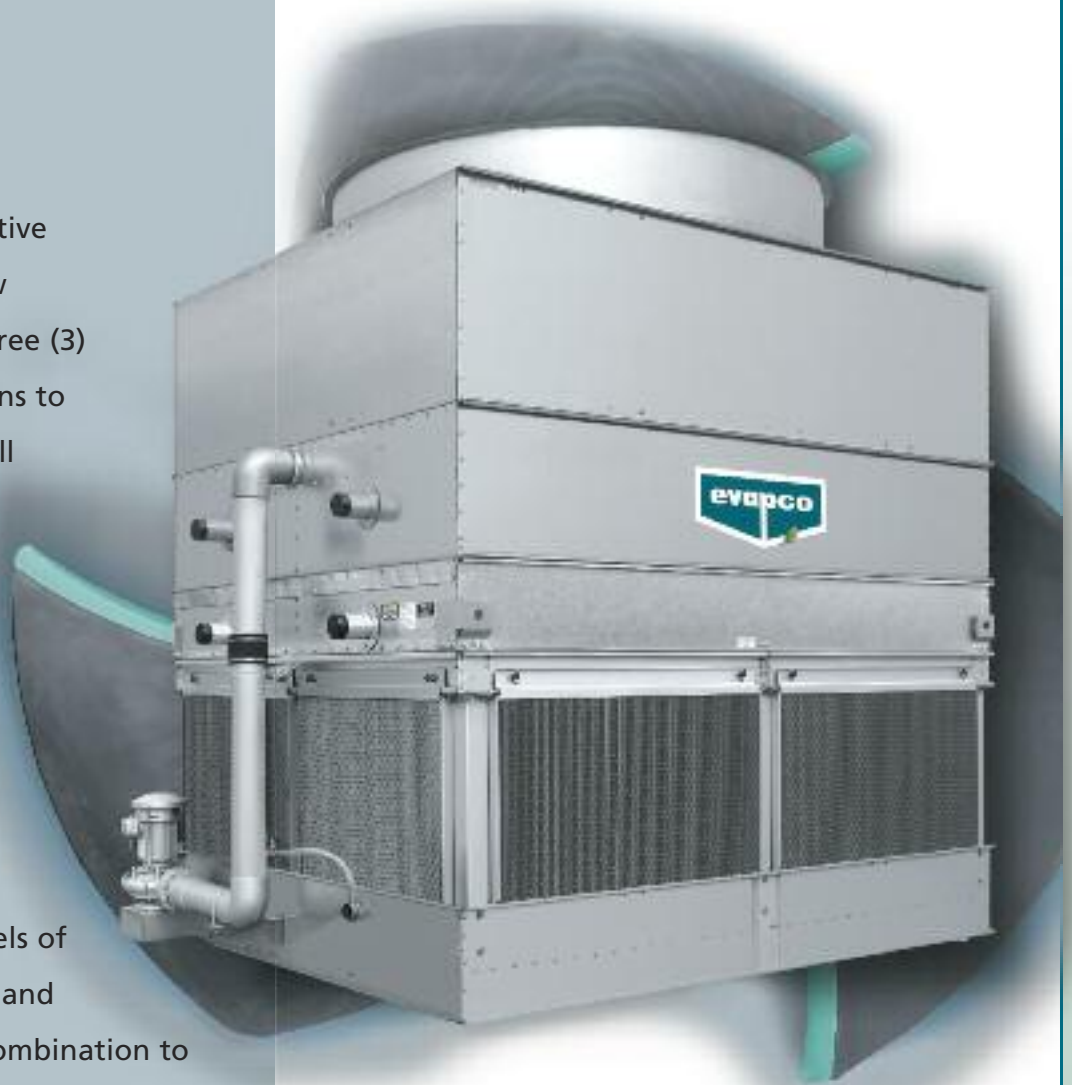

**Ultra Quiet operation
for induced draft
counterflow
Evaporative Condensers**

SOUND

ATC-E

ADVANCED TECHNOLOGY LOW SOUND SOLUTIONS

Super Low Sound Solution for Sound Sensitive Applications



Family of Super Low Sound Fans

The Super Low Sound Fan

Reduced Sound Levels versus Model ATC-E Standard Fan

EVAPCO's Super Low Sound Fan on the ATC-E Evaporative Condensers utilizes an extremely wide chord blade design applied for sound sensitive applications where the lowest sound levels are desired. The fan is one piece molded heavy duty FRP construction utilizing a forward swept blade design. The Super Low Sound Fan reduces sound levels 9 to 15 dB(A) compared to the Model ATC-E standard fan.

Improved Sound Quality versus Model ATC-E Standard Fan

The SUPER Low Sound Fan on the ATC-E Condenser reduces sound levels 9-15 dB(A) and eliminates audible blade passing frequencies indicative of straight bladed axial type fans.

Refer to the Narrow Band Spectrum graph which shows how straight bladed axial fans produce blade passing frequencies – the same phenomena that produce the signature pulsating helicopter noise.

The blade passing frequencies are audible spikes in sound pressure levels, but are not apparent in the octave band sound spectrum.

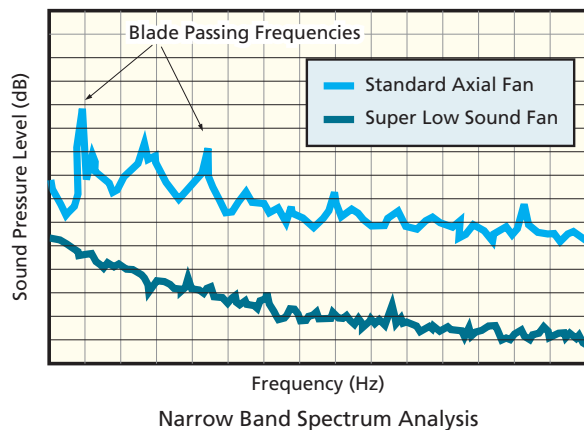

The Super Low Sound Fan on the ATC-E Evaporative Condensers reduces sound levels and betters the sound quality!

NOTE: These low sound options may impact the overall installed dimensions of the ATC-E Evaporative Condenser selected.

SOUND

ADVANCED TECHNOLOGY LOW SOUND SOLUTIONS

ATC-E

Additional Solutions for Sound Sensitive Applications



Low Sound Fan 4 – 7 dB(A) Reduction!

The Low Sound Fan offered by EVAPCO is a wide chord blade design for sound sensitive applications where low sound levels are desired. The Low Sound Fan shall utilize a unique soft-connect blade-to-hub design that is compatible with Variable Speed Drives.

The Low Sound Fan is capable of reducing the unit sound pressure levels 4 dB(A) to 7 dB(A), depending upon specific unit selection and measurement location. The fans are high efficiency axial propeller type and are available on 2.4 m wide and larger ATC Evaporative Condensers.

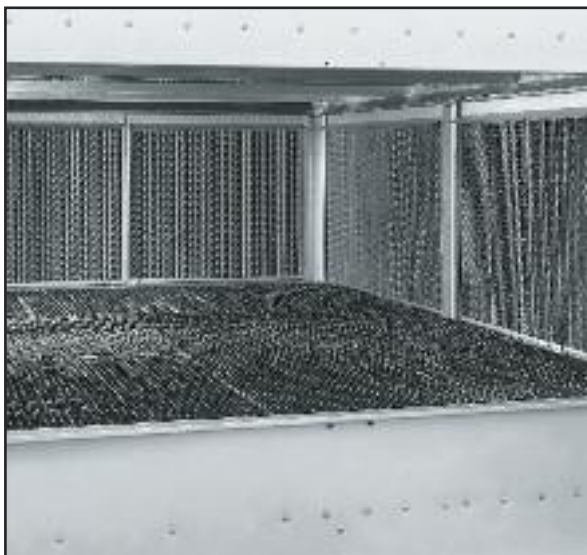

Water Silencer

Reduces Water Noise in the Cold Water Basin up to 7 dB(A)!

The water silencer option is available for all induced draft models and is located in the falling water area of the cold water basin. The water silencer will reduce the high frequency noise associated with the falling water and is capable of reducing overall sound levels **4 dB(A) to 7 dB(A)** measured at 1.5 m from the side or end of the unit. The water silencers reduce overall sound levels **9 dB(A) to 12 dB(A)** (depending on water loading and louver height) measured 1.5 m from the side or end of the unit when water is circulated with fans off.

The water silencers are constructed of lightweight PVC sections and can be easily removed for access to the basin area. *The water silencer will have no impact on unit thermal performance.*

The Water Silencer is available on ALL ATC Evaporative Condensers.

Consult EVAPCO's EvapSelect™ selection software for unit sound levels. If a detailed analysis or full octave band data sheet is required for your application, please consult your EVAPCO Sales Representative.

ATC-E

SOUND BASIC

Background in Sound Basics

Sound

Sound is the alteration in pressure, stress, particle displacement and particle velocity, which is propagated in an elastic material. Audible sound is the sensation produced at the ear by very small pressure fluctuations in the air.

Sound Pressure

Sound pressure is the *intensity* of sound. Sound pressure, L_p in decibels is the ratio of measured pressure, P in the air to a reference sound pressure, $P_0 = 2 \times 10^{-5}$ Pascal following the following formula:

$$L_p \text{ (dB)} = 10 \log_{10} (\Delta P^2 / \Delta P_0^2)$$

The most important point to understand about sound pressure level is that **sound pressure level is what is actually being measured when sound data is recorded.** Microphones that measure sound are pressure sensitive devices that are calibrated to convert the sound pressure waves into decibels.

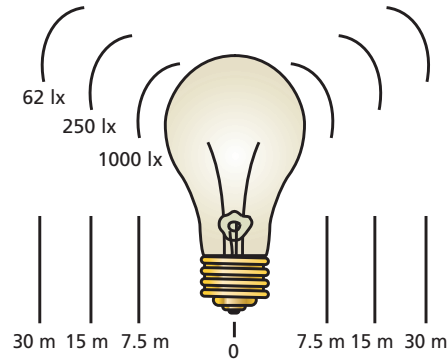

"SOUND PRESSURE"

Similar to the intensity coming from a light bulb which gets dimmer as one gets further and further away, sound pressure decreases in decibels as your ear gets further from the sound source.

Sound Power

Sound Power is the *energy* of sound. Sound power, L_w in decibels is the ratio of the calculated sound power, W to a reference power, $W_0 = 1$ picowatt, according to the following formula:

$$L_w \text{ (dB)} = 10 \log_{10} (W/W_0)$$

The most important point to remember about **sound power level is that sound power level is not a measured value, but is calculated based on the measured sound pressure.**

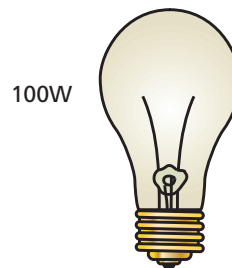

"SOUND POWER"

Similar to the wattage of a light bulb that does not change the farther one is away from the light bulb, sound power does not vary with distance.

Adding Multiple Sound Sources

Since the decibel is a logarithmic function, the numbers are not added linearly. Therefore, two 73 dB sound sources added together do not equal 146 dB. The resultant sound would actually be 76 dB. The following table shows how to add decibels from two sound sources.

Difference in dB Level	Add to the higher dB Level
0 to 1	3
2 to 3	2
4 to 8	1
9 or greater	0

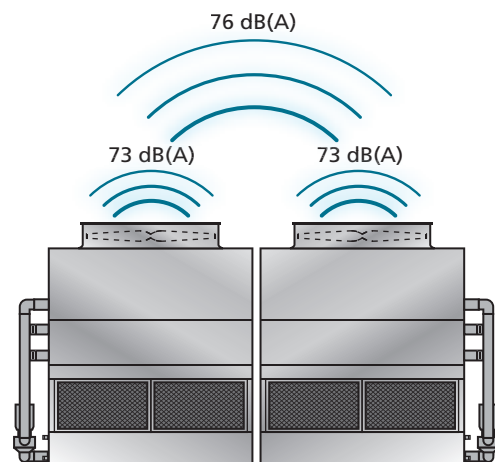

SOUND

SOUND BASIC

ATC-E

Sound Science and Condensers

Sound Frequency

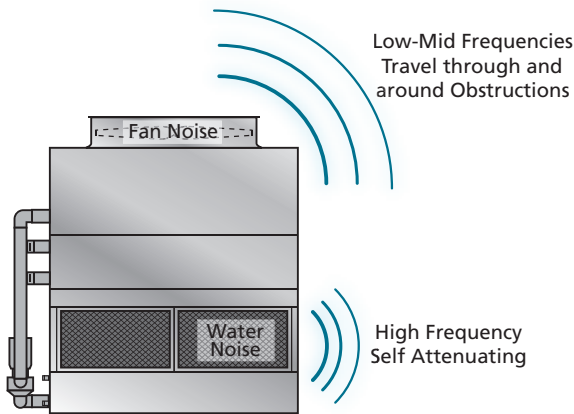

Fan Noise

- Low / Mid frequencies that travel long distances, through walls, and around obstructions.
- Very difficult to attenuate. Reduce fan noise by using Low Sound Fans.
- Dominates what is measured and heard at the Condenser and at the sound sensitive location.

Water Noise

- High frequencies that attenuate naturally with distance. Attenuated easily by walls, trees or other obstructions.
- Totally masked and drowned out by fan noise at a short distance away from the Condenser.

Sound Pressure – The A-Weighted Scale

The A-weighted scale, dB(A) is a means to translate what a sound meter microphone measures to how the human ear perceives the sound.

dB(A) Formula and Conversions:

$$dB(A) = 10 \log_{10} \sum_{f=63}^{f=8000} 10^{((dB+C_f)/10)}$$

where: C_f = correction factor per band
 dB = measured sound pressure
 let: $Z_f = (dB + C_f)/10$

Band	Center Freq. (Hz)	Frequency Range (Hz)	Sample Data (dB)	C_f (dB)	Z_f
1	63	44-88	68	-26.2	4.18
2	125	89-175	76	-16.1	5.99
3	250	176-350	77	-8.6	6.84
4	500	351-700	73	-3.2	6.98
5	1000	701-1400	70	0	7.00
6	2000	1401-2800	68	+1.2	6.92
7	4000	2801-5600	71	+1.0	7.20
8	8000	5601-11200	73	-1.1	7.19

Typical Sound Pressure Levels of Well Known Noises:

Jet Airplane, 45 meters away	140 dB(A)
Painful	130 dB(A)
Very Uncomfortable	120 dB(A)
Circular Saw	110 dB(A)
Nightclub	100 dB(A)
Semi Truck	90 dB(A)
Sidewalk of a Busy Road	80 dB(A)
Household Vacuum, 1 meter away	70 dB(A)
Normal Conversation	60 dB(A)
Inside Average Home	50 dB(A)
Quiet Library	40 dB(A)
Bedroom at Night	30 dB(A)

Notable Facts about Sound:

- +/- 1 dB(A) is inaudible to the human ear
- Decreasing a noise source by 10 dB(A) sounds half as loud to the human ear

Example calculation of the dB(A) formula using the Sample Data above.

$$dB(A) = 10 \log_{10} \sum 10^{Z_1} + 10^{Z_2} + 10^{Z_3} + 10^{Z_4} + 10^{Z_5} + 10^{Z_6} + 10^{Z_7} + 10^{Z_8}$$

$$= 10 \log_{10} (67114245.2) = 78.3 \text{ dB(A)}$$

SOUND

ATC-E

SPECIFYING SOUND

Sound Verifications

Specify sound pressure in dB(A) measured 1,5 m above the fan discharge during full speed operation.

- All manufacturers can meet a performance specification with Low Sound Options
- Fan noise is what matters. 1,5 m above the fan is where it matters.

Measurement Location

Per Cooling Technology Institute Standard ATC-128

Sound Microphone location 1,5 m above the evaporative condenser fan cowl edge at a 45° angle.

This position assures accurate sound measurements by eliminating a source of uncertainty by taking the microphone out of the high velocity fan discharge air.

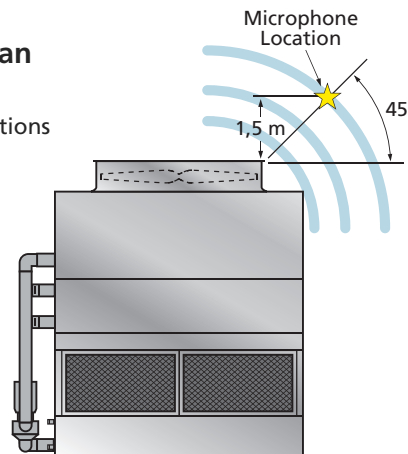

Easy Verification

At 1,5 m from the Evaporative Condenser, a sound meter records only condenser noise. Interested parties can easily verify the actual noise coming from the condenser against the specified sound data with good certainty.

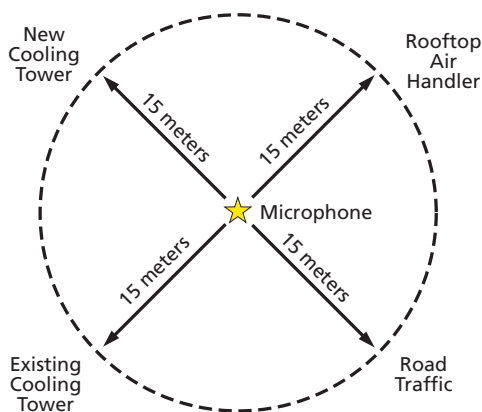

If sound were specified at 15 meters or some greater distance from the sound sensitive location, there is increased uncertainty in the measured data due to other possible sound sources within the 15 meters radius of the sound microphone.

Sound Quality

Sound coming from the top of the condenser is comprised of low- and mid-frequency fan noise. Low- and mid-frequency fan "rumble" is very difficult to attenuate. Fan rumble travels through everything and around everything and what is audible at any sound sensitive location.

Sound coming from the sides of the condenser is comprised of high frequency water noise, is much less objectionable than fan noise and attenuates naturally with distance.

Acoustical Shadow*

"Subjective reactions to the overall noise generated by Condensers indicate that as one walks away from a tower intake, a point is reached where the water noise is masked by the fan noise. The point coincides with the point at which one emerges from the acoustical shadow of the condenser structure, which shields intake water noise from discharge fan noise."

*Seelbach & Oran, "What To Do About Cooling Tower Noise", Industrial Acoustics Company.

Sound measured at the side of an Evaporative Condenser is inside the acoustical shadow of the noise emitted from the top. Outside the acoustical shadow, the low- and mid-frequency fan noise completely masks the high frequency water noise.

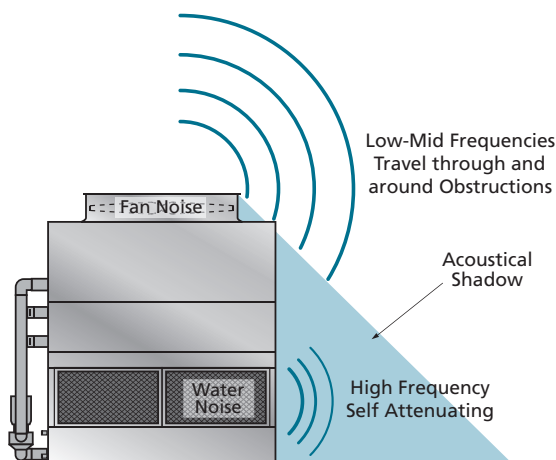

Specify fan noise because it matters! Specify fan noise where it matters!

ATC-E



We Stand Tall Through it All!

Wind, Rain, Earthquake and Hurricane

The International Building Code (IBC) is a comprehensive set of regulations addressing the structural design and installation requirements for building systems – including HVAC and industrial refrigeration equipment.

With the advent of the IBC, EVAPCO is proud to introduce the new and improved line of ATC-E Evaporative Condensers with IBC 2012 compliance standard.

***EVAPCO Evaporative Condensers...
designed to withstand seismic
or wind load forces.***

ATC-E

IBC COMPLIANCE

In its continuing commitment to be the leaders in evaporative cooling equipment design and services, EVAPCO ATC-E Evaporative Condensers are now **Independently Certified** to withstand Seismic and Wind Loads in accordance with IBC 2012.

What is IBC?

International Building Code

The International Building Code (IBC) is a comprehensive set of regulations addressing both the structural design and the installation requirements for building systems – including HVAC and industrial refrigeration equipment. Compared to previous building codes that considered only the building structure and component anchorage, the requirements contained within the IBC address anchorage, structural integrity, and the operational capability of a component following either a seismic or wind load event. **Simply stated, the IBC code provisions require that evaporative cooling equipment, and all other components permanently installed on a structure, must be designed to meet the same seismic or wind load forces as the building to which they are attached.**

How Does IBC 2012 Apply to Evaporative Condensers?

Based on site design factors, calculations are made to determine the equivalent seismic “g force” and wind load (kilo-Newton per square meter, kN/m²) on the unit. The evaporative condenser must be designed to withstand the greater of either the seismic or wind load.

The New ATC-E is offered with a choice of TWO structural design packages:

- **Standard Structural Design** – For projects with ≤1.0g seismic or 6,94 kN/m² wind loads
- **Upgraded Structural Design** – Required for projects with >1.0 g seismic or 6,94 kN/m² wind loads

All locations with design criteria resulting in a seismic design force of up to 1.0g or a wind load of 6,94 kN/m² or below will be provided with the standard ATC-E structural design. An upgraded structural design is available for installations with design criteria resulting in “g forces” greater than 1.0g. The highest “g force” location in North America is 5.12g. The highest wind load shown on the maps is 273 km/h, which is approximately equal to 6,94 kN/m² velocity pressure. **Therefore, the upgraded structural design package option for the New ATC-E is designed for 5.12 g and 6,94 kN/m² making it applicable to ALL building locations in North America.**

Design Implementation

EVAPCO applies the seismic design and wind load information provided for the project to determine the equipment design necessary to meet IBC requirements. This process ensures that the mechanical equipment and its components are compliant per the provisions of the IBC as given in the plans and specifications for the project.

Independent Certification

Although the IBC references and is based on the structural building code ASCE 7, many chapters and paragraphs of ASCE 7 are superceded by the IBC, independent certification and methods of analysis are such paragraphs. Per the most recent edition of the code, the EVAPCO compliance process included an exhaustive analysis by an independent approval agency. As required by the International Building Code, EVAPCO supplies a certificate of compliance as part of its submittal documents. The certificate of compliance demonstrates that the equipment has been independently tested and analyzed in accordance with the IBC seismic and wind load requirements. Evapco has worked closely with the independent approval agency, The VMC Group, to complete the independent equipment testing and analysis.

If the seismic “g force” or wind load psf requirements for the project site are known, EVAPCO’s online equipment selection software, *EvapSelect™*, will allow you to choose the required structural design package – either standard construction or upgraded construction.

For further questions regarding IBC compliance, please contact your local EVAPCO Representative.

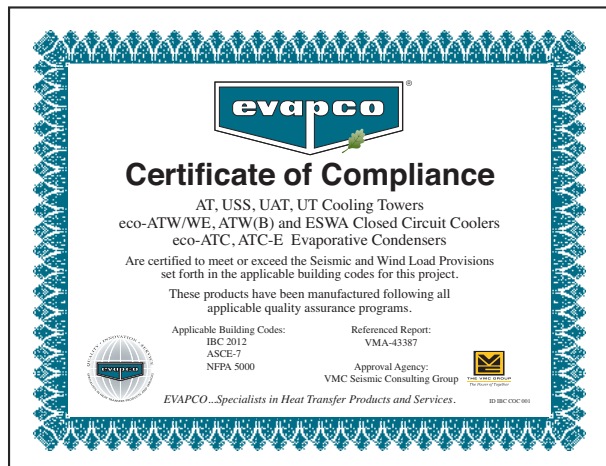

ATC-E

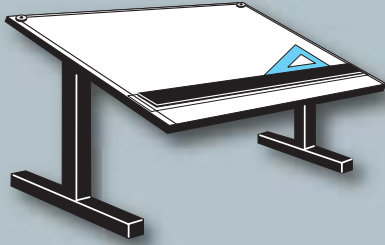

Engineering Data & Dimensions

ATC-E

ENGINEERING DATA & DIMENSIONS

MODELS: 50E TO 165E

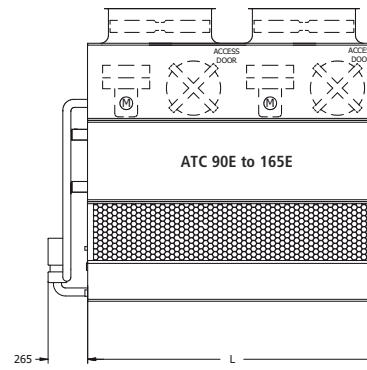
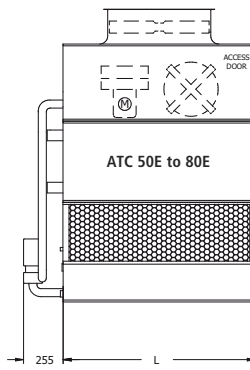
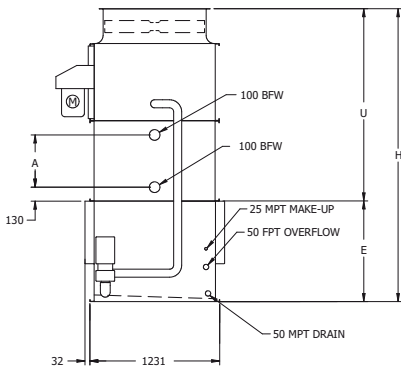

ATC-E Model No.	Fans		Weights (kg)			Refrigerant Operating Charge** (kg)	Coil Volume (l)	Spray Pump kW	Remote Sump††			Dimensions ^Δ (mm)				
	kW	m ³ /s	Shipping	Operating	Heaviest Section				Liters Req'd*	Conn. Size(mm)	Operating Weight	Height H	Upper U	Lower E	Coil A	Length L
50E	2,2	5,6	1260	1795	1030	23	198	0,55	455	150	1590	2778	1822	956	495	1822
65E	4	5,9	1435	1980	1200	30	255	0,55	455	150	1775	2969	2013	956	686	1822
80E	4	5,7	1620	2180	1390	37	313	0,55	455	150	1975	3159	2203	956	876	1822
90E	(2) 2,2	10,0	1865	2640	1560	34	288	0,75	680	150	2360	2778	1822	956	495	2737
105E	(2) 2,2	9,3	2115	2910	1810	44	376	0,75	680	150	2615	2969	2013	956	686	2737
120E	(2) 2,2	9,0	2380	3200	2075	54	463	0,75	680	150	2915	3159	2203	956	876	2737
135E	(2) 2,2	11,9	2580	3630	2210	58	496	1,1	870	200	3275	2969	2013	956	686	3651
150E	(2) 2,2	11,2	2945	4020	2570	72	613	1,1	870	200	3665	3159	2203	956	876	3651
165E	(2) 4	12,2	2955	4030	2580	72	613	1,1	870	200	3675	3159	2203	956	876	3651

† Heaviest section is the coil / fan section

†† When a remote sump arrangement is selected, the spray pump, suction strainer and associated piping are omitted; the unit is provided with an oversized outlet to facilitate drainage to the remote sump

* Liters shown is water in suspension in unit and piping. Allow for additional water in bottom of remote sump to cover pump suction and strainer during operation. (300mm would normally be sufficient).

** Refrigerant charge is shown for R-717. Multiply by 1.93 for R22, 1.98 for R134A and 1.7 for R404A, R410A and R507A.

Δ Unit dimensions and coil connections may vary slightly from catalog. See factory certified prints for dimensions, quantity of coil connections, and piping configuration. Coil connections are 4" bevel for weld (BFW).

ENGINEERING DATA & DIMENSIONS

ATC-E

MODELS: M170E TO M331E

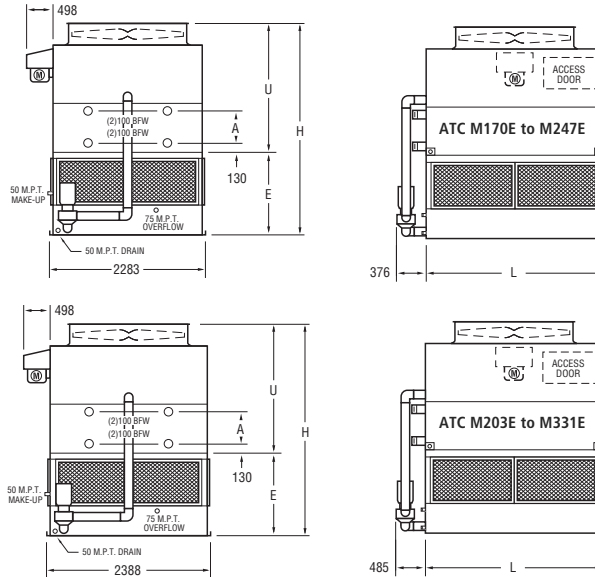

ENGINEERING

ATC-E Model No.	Fans		Weights (kg)			Refrigerant Operating Charge** (kg)	Coil Volume (l)	Spray Pump kW	Remote Sump††			Dimensions ^Δ (mm)				
	kW	m ³ /s	Shipping	Operating	Heaviest Section†				Liters Req'd*	Conn. Size(mm)	Operating Weight	Height H	Upper U	Lower E	Coil A	Length L
M170E	4	14,0	3505	4675	2915	83	707	1,5	835	200	4180	3423	2197	1226	686	2578
M187E	5,5	16,0	3530	4700	2940	83	707	1,5	835	200	4200	3423	2197	1226	686	2578
M199E	7,5	17,6	3535	4705	2945	83	707	1,5	835	200	4205	3423	2197	1226	686	2578
M188E	4	13,6	3980	5185	3390	103	872	1,5	835	200	4685	3613	2388	1226	876	2578
M221E	7,5	17,0	4005	5210	3415	103	872	1,5	835	200	4715	3613	2388	1226	876	2578
M238E	11	19,1	4065	5270	3475	103	872	1,5	835	200	4770	3613	2388	1226	876	2578
M195E	4	13,2	4445	5690	3855	122	1038	1,5	835	200	5190	3804	2578	1226	1067	2578
M247E	11	18,5	4530	5775	3940	122	1038	1,5	835	200	5275	3804	2578	1226	1067	2578
M203E	5,5	17,2	3975	5255	3340	88	751	1,5	910	200	4695	3629	2311	1318	686	2731
M225E	5,5	16,7	4505	5825	3870	109	926	1,5	910	200	5265	3820	2502	1318	876	2731
M233E	5,5	16,1	5025	6380	4390	130	1102	1,5	910	200	5825	4010	2692	1318	1067	2731
M252E	7,5	21,0	4585	6095	3860	102	871	2,2	1060	250	5440	3629	2311	1318	686	3188
M274E	11	23,6	4640	6150	3915	102	871	2,2	1060	250	5495	3629	2311	1318	686	3188
M278E	7,5	20,3	5205	6765	4480	127	1076	2,2	1060	250	6105	3820	2502	1318	876	3188
M303E	11	22,9	5260	6815	4535	127	1076	2,2	1060	250	6160	3820	2502	1318	876	3188
M320E	15	24,9	5290	6845	4565	127	1076	2,2	1060	250	6185	3820	2502	1318	876	3188
M331E	15	24,1	5895	7500	5170	151	1282	2,2	1060	250	6840	4010	2692	1318	1067	3188

The motors are shipped loose for field mounting.

† Heaviest section is the coil / fan section

†† When a remote sump arrangement is selected, the spray pump, suction strainer and associated piping are omitted; the unit is provided with an oversized outlet to facilitate drainage to the remote sump

* Liters shown is water in suspension in unit and piping. Allow for additional water in bottom of remote sump to cover pump suction and strainer during operation. (300mm would normally be sufficient).

** Refrigerant charge is shown for R-717. Multiply by 1.93 for R22, 1.98 for R134A and 1.7 for R404A, R410A and R507A.

Δ Unit dimensions and coil connections may vary slightly from catalog. See factory certified prints for dimensions, quantity of coil connections, and piping configuration. Coil connections are 4" bevel for weld (BFW).

ATC-E

ENGINEERING DATA & DIMENSIONS

MODELS: M301E TO M591E

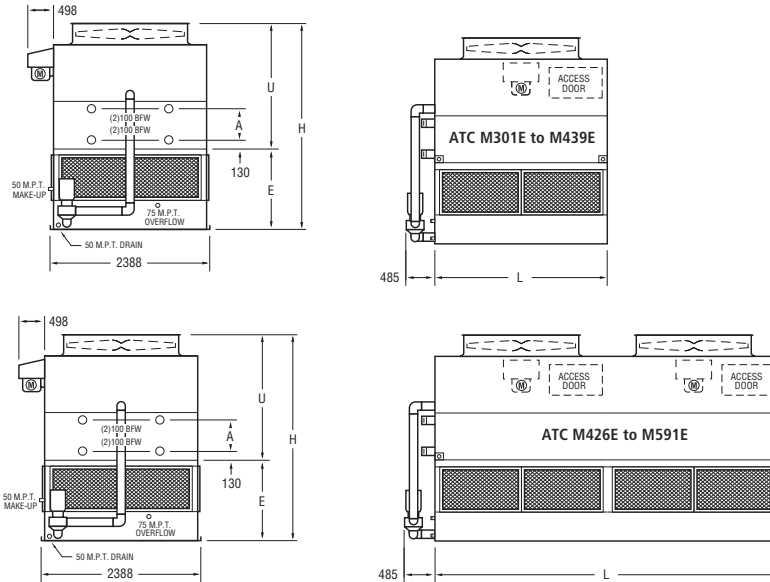

ATC-E Model No.	Fans		Weights (kg)			Refrigerant Operating Charge** (kg)	Coil Volume (l)	Spray Pump kW	Remote Sump††			Dimensions ^Δ (mm)				
	kW	m ³ /s	Shipping	Operating	Heaviest Section				Liters Req'd*	Conn. Size(mm)	Operating Weight	Height H	Upper U	Lower E	Coil A	Length L
M301E	11	24,8	5060	6820	4255	117	991	2,2	1210	250	6085	3629	2311	1318	686	3651
M304E	7,5	21,1	5670	7490	4865	144	1227	2,2	1210	250	6750	3820	2502	1318	876	3651
M352E	15	26,0	5750	7570	4950	144	1227	2,2	1210	250	6830	3820	2502	1318	876	3651
M314E	7,5	20,5	6375	8240	5570	172	1462	2,2	1210	250	7500	4010	2692	1318	1067	3651
M344E	11	23,3	6425	8295	5625	172	1462	2,2	1210	250	7555	4010	2692	1318	1067	3651
M380E	18,5	26,9	6470	8335	5665	172	1462	2,2	1210	250	7600	4010	2692	1318	1067	3651
M337E	11	24,1	5715	7770	4820	135	1152	2,2	1365	250	6920	3740	2311	1429	686	4261
M358E	15	27,6	5740	7795	4850	135	1152	2,2	1365	250	6950	3740	2311	1429	686	4261
M373E	18,5	30,0	5755	7810	4865	135	1152	2,2	1365	250	6965	3740	2311	1429	686	4261
M371E	11	23,4	6485	8605	5595	168	1427	2,2	1365	250	7755	3931	2502	1429	876	4261
M393E	15	26,8	6515	8630	5620	168	1427	2,2	1365	250	7785	3931	2502	1429	876	4261
M410E	18,5	29,1	6525	8645	5635	168	1427	2,2	1365	250	7795	3931	2502	1429	876	4261
M383E	11	22,7	7300	9475	6405	200	1702	2,2	1365	250	8625	4121	2692	1429	1067	4261
M407E	15	26,0	7325	9505	6430	200	1702	2,2	1365	250	8655	4121	2692	1429	1067	4261
M424E	18,5	28,2	7340	9515	6445	200	1702	2,2	1365	250	8670	4121	2692	1429	1067	4261
M439E	22	30,0	7360	9540	6470	200	1702	2,2	1365	250	8690	4121	2692	1429	1067	4261
M426E	(2) 5,5	28,5	7620	10285	6380	173	1472	4	1815	300	9185	3842	2311	1530	686	5486
M456E	(2) 7,5	32,6	7635	10300	6395	173	1472	4	1815	300	9200	3842	2311	1530	686	5486
M494E	(2) 11	35,9	7745	10415	6510	173	1472	4	1815	300	9310	3842	2311	1530	686	5486
M467E	(2) 5,5	27,6	8605	11355	7365	215	1827	4	1815	300	10250	4032	2502	1530	876	5486
M500E	(2) 7,5	31,6	8620	11365	7380	215	1827	4	1815	300	10265	4032	2502	1530	876	5486
M541E	(2) 11	34,8	8730	11480	7495	215	1827	4	1815	300	10380	4032	2502	1530	876	5486
M483E	(2) 5,5	26,8	9655	12485	8420	257	2183	4	1815	300	11380	4223	2692	1530	1067	5486
M591E	(2) 15	37,8	9840	12665	8600	257	2183	4	1815	300	11560	4223	2692	1530	1067	5486

The motors are shipped loose for field mounting.

† Heaviest section is the coil / fan section

†† When a remote sump arrangement is selected, the spray pump, suction strainer and associated piping are omitted; the unit is provided with an oversized outlet to facilitate drainage to the remote sump

* Liters shown is water in suspension in unit and piping. Allow for additional water in bottom of remote sump to cover pump suction and strainer during operation. (300mm would normally be sufficient).

** Refrigerant charge is shown for R-717. Multiply by 1.93 for R22, 1.98 for R134A and 1.7 for R404A, R410A and R507A.

Δ Unit dimensions and coil connections may vary slightly from catalog. See factory certified prints for dimensions, quantity of coil connections, and piping configuration. Coil connections are 4" bevel for weld (BFW).

ENGINEERING DATA & DIMENSIONS

ATC-E

MODELS: M523E TO M877E

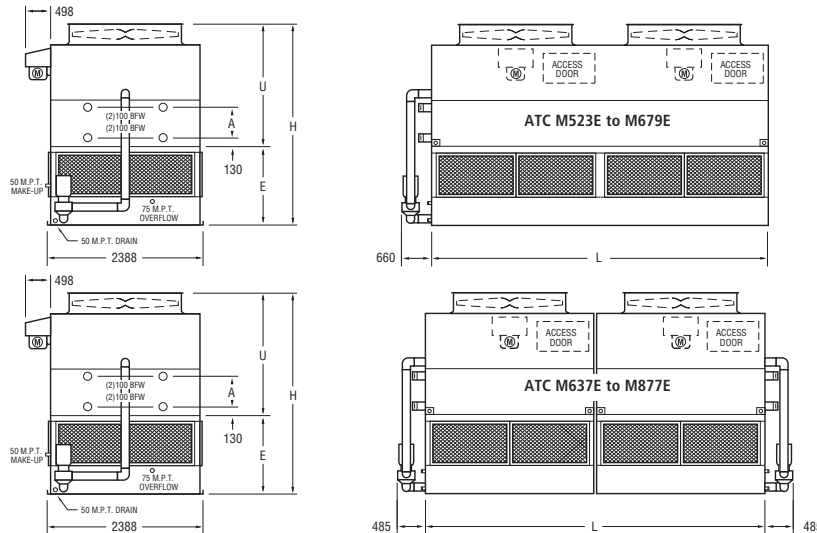

ENGINEERING

ATC-E Model No.	Fans		Weights (kg)			Refrigerant Operating Charge** (kg)	Coil Volume (l)	Spray Pump kW	Remote Sump††			Dimensions ^Δ (mm)				
	kW	m ³ /s	Shipping	Operating	Heaviest Section†				Liters Req'd*	Conn. Size(mm)	Operating Weight	Height H	Upper U	Lower E	Coil A	Length L
M523E	(2) 7,5	47,5	8670	11825	7305	201	1712	5,5	2120	300	10535	3842	2311	1530	686	6401
M570E	(2) 11	47,5	8780	11940	7420	201	1712	5,5	2120	300	10650	3842	2311	1530	686	6401
M572E	(2) 7,5	46,1	9805	13055	8445	250	2128	5,5	2120	300	11765	4032	2502	1530	876	6401
M624E	(2) 11	46,1	9920	13170	8560	250	2128	5,5	2120	300	11880	4032	2502	1530	876	6401
M659E	(2) 15	49,9	9975	13220	8615	250	2128	5,5	2120	300	11935	4032	2502	1530	876	6401
M590E	(2) 7,5	44,6	11020	14360	9655	299	2543	5,5	2120	300	13075	4223	2692	1530	1067	6401
M643E	(2) 11	44,6	11130	14475	9770	299	2543	5,5	2120	300	13185	4223	2692	1530	1067	6401
M679E	(2) 15	48,4	11185	14530	9825	299	2543	5,5	2120	300	13240	4223	2692	1530	1067	6401
M637E	(2) 15	56,6	10170	13700	4280	233	1983	(2) 2,2	2425	(2) 250	12220	3842	2311	1530	686	7366
M607E	(2) 7,5	44,5	11340	14980	4865	288	2453	(2) 2,2	2425	(2) 250	13500	4032	2502	1530	876	7366
M666E	(2) 11	50,6	11450	15085	4920	288	2453	(2) 2,2	2425	(2) 250	13610	4032	2502	1530	876	7366
M704E	(2) 15	54,9	11505	15140	4950	288	2453	(2) 2,2	2425	(2) 250	13660	4032	2502	1530	876	7366
M628E	(2) 7,5	43,1	12745	16485	5570	344	2924	(2) 2,2	2425	(2) 250	15005	4223	2692	1530	1067	7366
M689E	(2) 11	49,1	12855	16590	5625	344	2924	(2) 2,2	2425	(2) 250	15115	4223	2692	1530	1067	7366
M759E	(2) 18,5	56,6	12935	16675	5665	344	2924	(2) 2,2	2425	(2) 250	15195	4223	2692	1530	1067	7366
M674E	(2) 11	58,2	11430	15540	4820	271	2303	(2) 2,2	2725	(2) 250	13845	3994	2311	1683	686	8585
M715E	(2) 15	63,2	11485	15595	4850	271	2303	(2) 2,2	2725	(2) 250	13900	3994	2311	1683	686	8585
M746E	(2) 18,5	67,3	11510	15620	4865	271	2303	(2) 2,2	2725	(2) 250	13925	3994	2311	1683	686	8585
M741E	(2) 11	56,6	12975	17210	5595	336	2854	(2) 2,2	2725	(2) 250	15515	4185	2502	1683	876	8585
M786E	(2) 15	61,4	13025	17265	5620	336	2854	(2) 2,2	2725	(2) 250	15565	4185	2502	1683	876	8585
M819E	(2) 18,5	65,3	13055	17290	5635	336	2854	(2) 2,2	2725	(2) 250	15595	4185	2502	1683	876	8585
M767E	(2) 11	54,8	14595	18950	6405	400	3404	(2) 2,2	2725	(2) 250	17255	4375	2692	1683	1067	8585
M813E	(2) 15	59,5	14650	19005	6430	400	3404	(2) 2,2	2725	(2) 250	17310	4375	2692	1683	1067	8585
M848E	(2) 18,5	63,2	14680	19035	6445	400	3404	(2) 2,2	2725	(2) 250	17335	4375	2692	1683	1067	8585
M877E	(2) 22	66,6	14725	19080	6470	400	3404	(2) 2,2	2725	(2) 250	17380	4375	2692	1683	1067	8585

The motors are shipped loose for field mounting.

† Heaviest section is the coil / fan section

†† When a remote sump arrangement is selected, the spray pump, suction strainer and associated piping are omitted; the unit is provided with an oversized outlet to facilitate drainage to the remote sump

* Liters shown is water in suspension in unit and piping. Allow for additional water in bottom of remote sump to cover pump suction and strainer during operation. (300mm would normally be sufficient).

** Refrigerant charge is shown for R-717. Multiply by 1.93 for R22, 1.98 for R134A and 1.7 for R404A, R410A and R507A.

Δ Unit dimensions and coil connections may vary slightly from catalog. See factory certified prints for dimensions, quantity of coil connections, and piping configuration. Coil connections are 4" bevel for weld (BFW).

ATC-E

ENGINEERING DATA & DIMENSIONS

MODELS: M852E TO M1358E

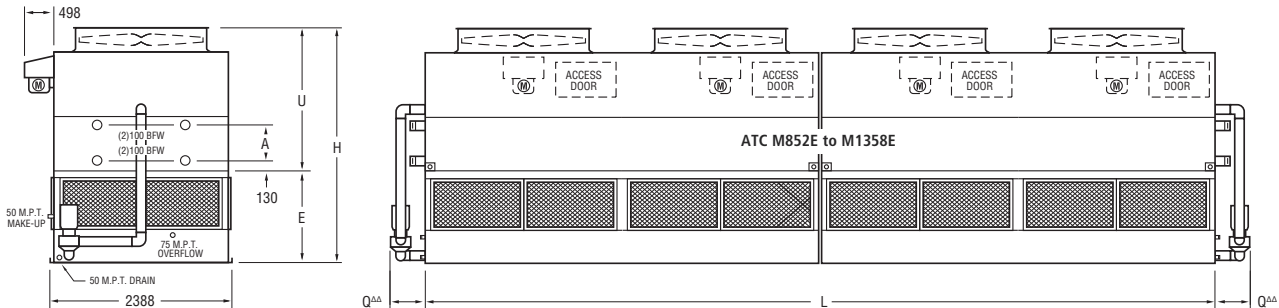

ATC-E Model No.	Fans		Weights (kg)			Refrigerant Operating Charge** (kg)	Coil Volume (l)	Spray Pump kW	Remote Sump††			Dimensions ^Δ (mm)				
	kW	m ³ /s	Shipping	Operating	Heaviest Section†				Liters Req'd*	Conn. Size(mm)	Operating Weight	Height H	Upper U	Lower E	Coil A	Length L
M852E	(4) 5,5	68,7	15240	20575	6380	346	2944	(2) 4	3635	(2) 300	18370	3994	2311	1683	686	11036
M912E	(4) 7,5	75,5	15270	20600	6395	346	2944	(2) 4	3635	(2) 300	18400	3994	2311	1683	686	11036
M987E	(4) 11	84,6	15495	20830	6510	346	2944	(2) 4	3635	(2) 300	18625	3994	2311	1683	686	11036
M934E	(4) 5,5	66,7	17210	22705	7365	430	3655	(2) 4	3635	(2) 300	20500	4185	2502	1683	876	11036
M1000E	(4) 7,5	73,4	17235	22735	7380	430	3655	(2) 4	3635	(2) 300	20530	4185	2502	1683	876	11036
M1083E	(4) 11	82,1	17465	22960	7495	430	3655	(2) 4	3635	(2) 300	20755	4185	2502	1683	876	11036
M1179E	(4) 15	86,2	19675	25330	8600	513	4365	(2) 4	3635	(2) 300	23125	4375	2692	1683	1067	11036
M1046E	(4) 7,5	84,0	17335	23650	7305	403	3424	(2) 5,5	4240	(2) 300	21075	3994	2311	1683	686	12865
M1140E	(4) 11	95,0	17565	23875	7420	403	3424	(2) 5,5	4240	(2) 300	21300	3994	2311	1683	686	12865
M1144E	(4) 7,5	81,5	19615	26110	8445	500	4255	(2) 5,5	4240	(2) 300	23530	4185	2502	1683	876	12865
M1248E	(4) 11	92,2	19840	26335	8560	500	4255	(2) 5,5	4240	(2) 300	23760	4185	2502	1683	876	12865
M1317E	(4) 15	99,9	19950	26445	8615	500	4255	(2) 5,5	4240	(2) 300	23870	4185	2502	1683	876	12865
M1180E	(4) 7,5	79,0	22035	28720	9655	598	5086	(2) 5,5	4240	(2) 300	26145	4375	2692	1683	1067	12865
M1287E	(4) 11	89,2	22260	28950	9770	598	5086	(2) 5,5	4240	(2) 300	26370	4375	2692	1683	1067	12865
M1358E	(4) 15	96,7	22370	29055	9825	598	5086	(2) 5,5	4240	(2) 300	26480	4375	2692	1683	1067	12865

The motors are shipped loose for field mounting.

† Heaviest section is the coil / fan section

†† When a remote sump arrangement is selected, the spray pump, suction strainer and associated piping are omitted; the unit is provided with an oversized outlet to facilitate drainage to the remote sump

* Liters shown is water in suspension in unit and piping. Allow for additional water in bottom of remote sump to cover pump suction and strainer during operation. (300mm would normally be sufficient).

** Refrigerant charge is shown for R-717. Multiply by 1.93 for R22, 1.98 for R134A and 1.7 for R404A, R410A and R507A.

Δ Unit dimensions and coil connections may vary slightly from catalog. See factory certified prints for dimensions, quantity of coil connections, and piping configuration. Coil connections are 4" bevel for weld (BFW).

ΔΔ Q is 485 mm for 4 kW pumps, 660 mm for 5 and 7,5 kW pumps.

ENGINEERING DATA & DIMENSIONS

ATC-E

MODELS: M501E TO M844E

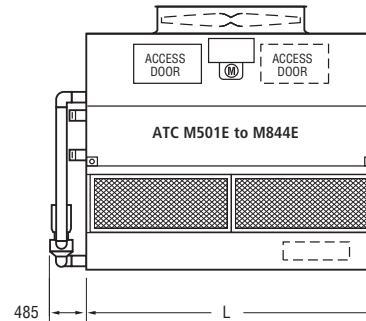
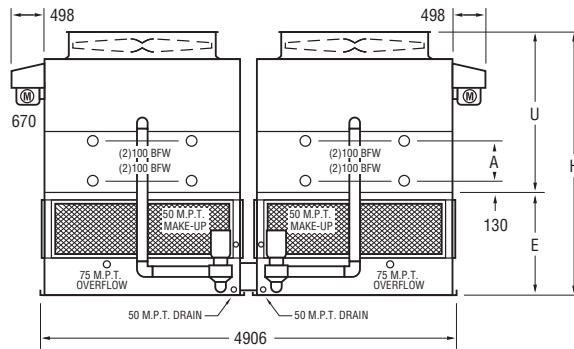

ATC-E Model No.	Fans		Weights (kg)			Refrigerant Operating Charge** (kg)	Coil Volume (l)	Spray Pump kW	Remote Sump††			Dimensions ^Δ (mm)				
	kW	m ³ /s	Shipping	Operating	Heaviest Section†				Liters Req'd*	Conn. Size(mm)	Operating Weight	Height H	Upper U	Lower E	Coil A	Length L
M501E	(2) 7,5	41,9	9170	12195	3860	205	1743	(2) 2,2	2120	(2) 250	10875	3842	2311	1530	686	3188
M546E	(2) 11	47,3	9280	12300	3915	205	1743	(2) 2,2	2120	(2) 250	10985	3842	2311	1530	686	3188
M603E	(2) 11	45,9	10525	13635	4535	253	2153	(2) 2,2	2120	(2) 250	12320	4032	2502	1530	876	3188
M636E	(2) 15	49,8	10580	13690	4565	253	2153	(2) 2,2	2120	(2) 250	12375	4032	2502	1530	876	3188
M658E	(2) 15	48,2	11795	14995	5170	301	2563	(2) 2,2	2120	(2) 250	13680	4223	2692	1530	1067	3188
M634E	(2) 15	56,6	10170	13700	4280	233	1983	(2) 2,2	2425	(2) 250	12220	3842	2311	1530	686	3651
M604E	(2) 7,5	44,5	11340	14980	4865	288	2453	(2) 2,2	2425	(2) 250	13500	4032	2502	1530	876	3651
M663E	(2) 11	50,6	11450	15085	4920	288	2453	(2) 2,2	2425	(2) 250	13610	4032	2502	1530	876	3651
M701E	(2) 15	54,9	11505	15140	4950	288	2453	(2) 2,2	2425	(2) 250	13660	4032	2502	1530	876	3651
M625E	(2) 7,5	43,1	12745	16485	5570	344	2924	(2) 2,2	2425	(2) 250	15005	4223	2692	1530	1067	3651
M685E	(2) 11	49,1	12855	16590	5625	344	2924	(2) 2,2	2425	(2) 250	15115	4223	2692	1530	1067	3651
M755E	(2) 18,5	56,6	12935	16675	5665	344	2924	(2) 2,2	2425	(2) 250	15195	4223	2692	1530	1067	3651
M712E	(2) 15	63,2	11485	15595	4850	271	2303	(2) 2,2	2725	(2) 250	13900	3994	2311	1683	686	4261
M742E	(2) 18,5	67,3	11510	15620	4865	271	2303	(2) 2,2	2725	(2) 250	13925	3994	2311	1683	686	4261
M782E	(2) 15	61,4	13025	17265	5620	336	2854	(2) 2,2	2725	(2) 250	15565	4185	2502	1683	876	4261
M815E	(2) 18,5	65,3	13055	17290	5635	336	2854	(2) 2,2	2725	(2) 250	15595	4185	2502	1683	876	4261
M809E	(2) 15	59,5	14650	19005	6430	400	3404	(2) 2,2	2725	(2) 250	17310	4375	2692	1683	1067	4261
M844E	(2) 18,5	63,2	14680	19035	6445	400	3404	(2) 2,2	2725	(2) 250	17335	4375	2692	1683	1067	4261

The motors are shipped loose for field mounting.

† Heaviest section is the coil / fan section

†† When a remote sump arrangement is selected, the spray pump, suction strainer and associated piping are omitted; the unit is provided with an oversized outlet to facilitate drainage to the remote sump

* Liters shown is water in suspension in unit and piping. Allow for additional water in bottom of remote sump to cover pump suction and strainer during operation. (300mm would normally be sufficient).

** Refrigerant charge is shown for R-717. Multiply by 1.93 for R22, 1.98 for R134A and 1.7 for R404A, R410A and R507A.

Δ Unit dimensions and coil connections may vary slightly from catalog. See factory certified prints for dimensions, quantity of coil connections, and piping configuration. Coil connections are 4" bevel for weld (BFW).

ATC-E

ENGINEERING DATA & DIMENSIONS

MODELS: XE298E TO XC669E

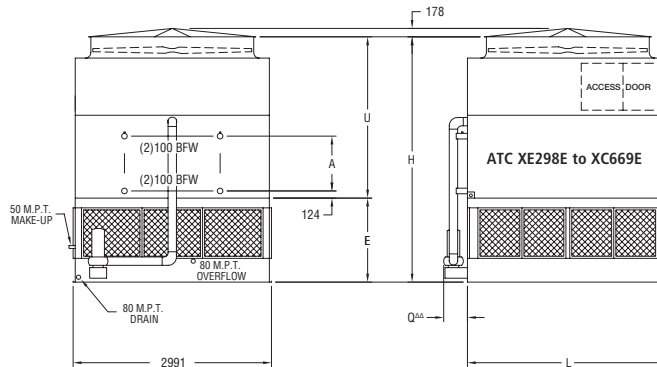

Optional Dual Fan units will have a "-DF" at the end of the model number. Fan kW and weights may vary.

ATC-E Model No.	Fans		Weights (kg)			Refrigerant Operating Charge** (kg)	Coil Volume (l)	Spray Pump kW	Remote Sump††			Dimensions ^Δ (mm)				
	kW	m ³ /s	Shipping	Operating	Heaviest Section†				Liters Req'd*	Conn. Size(mm)	Operating Weight	Height H	Upper U	Lower E	Coil A	Length L
XE298E	7,5	26,2	5620	8285	4465	113	959	4	1590	300	6665	4112	2530	1581	565	3651
XE333E	7,5	25,8	6475	9205	5315	148	1258	4	1590	300	7585	4328	2746	1581	781	3651
XC346E	15	33,0	5705	8370	4550	113	959	4	1590	300	6750	4112	2530	1581	565	3651
XE356E	7,5	25,4	7280	10080	6125	183	1557	4	1590	300	8460	4543	2962	1581	997	3651
XC360E	18,5	35,6	5720	8380	4565	113	959	4	1590	300	6765	4112	2530	1581	565	3651
XE368E	7,5	25,1	8150	11020	6995	218	1855	4	1590	300	9400	4759	3178	1581	1213	3651
XE387E	11	29,1	7340	10140	6180	183	1557	4	1590	300	8520	4543	2962	1581	997	3651
XC388E	15	32,5	6560	9290	5400	148	1258	4	1590	300	7670	4328	2746	1581	781	3651
XC402E	18,5	35,0	6575	9305	5415	148	1258	4	1590	300	7685	4328	2746	1581	781	3651
XC427E	18,5	34,5	7380	10180	6225	183	1557	4	1590	300	8560	4543	2962	1581	997	3651
XC443E	22	36,7	7405	10200	6245	183	1557	4	1590	300	8580	4543	2962	1581	997	3651
XC462E	22	36,2	8275	11140	7115	218	1855	4	1590	300	9520	4759	3178	1581	1213	3651
XE406E	7,5	35,1	7995	12015	6340	167	1417	5,5	2385	300	9635	4112	2530	1581	565	5486
XE448E	7,5	34,6	9260	13385	7605	220	1868	5,5	2385	300	11005	4328	2746	1581	781	5486
XE472E	7,5	34,1	10490	14715	8835	273	2320	5,5	2385	300	12335	4543	2962	1581	997	5486
XE492E	11	39,6	9320	13445	7665	220	1868	5,5	2385	300	11065	4328	2746	1581	781	5486
XC504E	18,5	47,6	8095	12115	6440	167	1417	5,5	2385	300	9735	4112	2530	1581	565	5486
XE516E	11	39,0	10550	14775	8895	273	2320	5,5	2385	300	12390	4543	2962	1581	997	5486
XC525E	22	50,6	8120	12140	6465	167	1417	5,5	2385	300	9755	4112	2530	1581	565	5486
XE528E	15	43,6	9350	13470	7695	220	1868	5,5	2385	300	11090	4328	2746	1581	781	5486
XE542E	11	38,4	11850	16170	10190	326	2771	5,5	2385	300	13790	4759	3178	1581	1213	5486
XE553E	15	42,9	10580	14800	8920	273	2320	5,5	2385	300	12420	4543	2962	1581	997	5486
XC558E	18,5	46,9	9360	13485	7705	220	1868	5,5	2385	300	11105	4328	2746	1581	781	5486
XC579E	18,5	46,3	10590	14815	8935	273	2320	5,5	2385	300	12435	4543	2962	1581	997	5486
XE608E	18,5	45,5	11890	16210	10235	326	2771	5,5	2385	300	13830	4759	3178	1581	1213	5486
XC611E	30	54,9	9455	13580	7800	220	1868	5,5	2385	300	11200	4328	2746	1581	781	5486
XC641E	30	54,1	10685	14910	9030	273	2320	5,5	2385	300	12530	4543	2962	1581	997	5486
XC669E	30	53,3	11985	16305	10330	326	2771	5,5	2385	300	13925	4759	3178	1581	1213	5486

The motors are shipped loose for field mounting.

† Heaviest section is the coil / fan section

†† When a remote sump arrangement is selected, the spray pump, suction strainer and associated piping are omitted; the unit is provided with an oversized outlet to facilitate drainage to the remote sump

* Liters shown is water in suspension in unit and piping. Allow for additional water in bottom of remote sump to cover pump suction and strainer during operation. (300mm would normally be sufficient).

** Refrigerant charge is shown for R-717. Multiply by 1.93 for R22, 1.98 for R134A and 1.7 for R404A, R410A and R507A.

Δ Unit dimensions and coil connections may vary slightly from catalog. See factory certified prints for dimensions, quantity of coil connections, and piping configuration. Coil connections are 4" bevel for weld (BFW).

ΔΔ Q is 485 mm for 4 kW pumps, 660 mm for 5 and 7,5 kW pumps.

ENGINEERING DATA & DIMENSIONS

ATC-E

MODELS: XE596E TO XC1340E

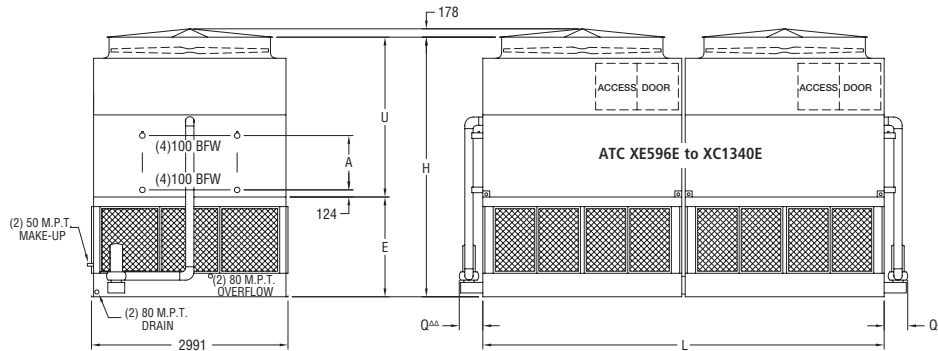

Optional Dual Fan units will have a "-DF" at the end of the model number. Fan kW and weights may vary.

ATC-E Model No.	Fans		Weights (kg)			Refrigerant Operating Charge** (kg)	Coil Volume (l)	Spray Pump kW	Remote Sump††			Dimensions ^Δ (mm)				
	kW	m ³ /s	Shipping	Operating	Heaviest Section				Liters Req'd*	Conn. Size(mm)	Operating Weight	Height H	Upper U	Lower E	Coil A	Length L
XE596E	(2) 7,5	52,4	11240	16565	4465	225	1918	(2) 4	3180	(2) 300	13325	4416	2530	1886	565	7366
XE665E	(2) 7,5	51,6	12945	18405	5315	296	2515	(2) 4	3180	(2) 300	15170	4632	2746	1886	781	7366
XE709E	(2) 7,5	50,9	14560	20160	6125	366	3113	(2) 4	3180	(2) 300	16920	4848	2962	1886	997	7366
XC720E	(2) 18,5	71,1	11440	16765	4565	225	1918	(2) 4	3180	(2) 300	13525	4416	2530	1886	565	7366
XE742E	(2) 7,5	50,1	16300	22035	6995	436	3711	(2) 4	3180	(2) 300	18795	5064	3178	1886	1213	7366
XC775E	(2) 15	65,0	13120	18580	5400	296	2515	(2) 4	3180	(2) 300	15340	4632	2746	1886	781	7366
XC804E	(2) 18,5	70,1	13145	18605	5415	296	2515	(2) 4	3180	(2) 300	15370	4632	2746	1886	781	7366
XC855E	(2) 18,5	69,0	14760	20355	6225	366	3113	(2) 4	3180	(2) 300	17120	4848	2962	1886	997	7366
XC884E	(2) 22	73,4	14805	20405	6245	366	3113	(2) 4	3180	(2) 300	17165	4848	2962	1886	997	7366
XC897E	(2) 18,5	68,0	16500	22235	7095	436	3711	(2) 4	3180	(2) 300	18995	5064	3178	1886	1213	7366
XC925E	(2) 22	72,3	16545	22280	7115	436	3711	(2) 4	3180	(2) 300	19040	5064	3178	1886	1213	7366
XE812E	(2) 7,5	70,2	15995	24030	6340	333	2833	(2) 5,5	4770	(2) 300	19270	4416	2530	1886	565	11036
XE896E	(2) 7,5	69,1	18525	26770	7605	439	3736	(2) 5,5	4770	(2) 300	22.010	4632	2746	1886	781	11036
XE947E	(2) 7,5	68,1	20985	29430	8835	545	4639	(2) 5,5	4770	(2) 300	24665	4848	2962	1886	997	11036
XE984E	(2) 11	79,1	18645	26890	7665	439	3736	(2) 5,5	4770	(2) 300	22.125	4632	2746	1886	781	11036
XC1011E	(2) 18,5	95,2	16195	24230	6440	333	2833	(2) 5,5	4770	(2) 300	19470	4416	2530	1886	565	11036
XE1032E	(2) 11	78,0	21100	29545	8895	545	4639	(2) 5,5	4770	(2) 300	24785	4848	2962	1886	997	11036
XC1049E	(2) 22	101,2	16240	24275	6465	333	2833	(2) 5,5	4770	(2) 300	19515	4416	2530	1886	565	11036
XC1112E	(2) 18,5	93,9	18725	26970	7705	439	3736	(2) 5,5	4770	(2) 300	22210	4632	2746	1886	781	11036
XC1153E	(2) 22	99,7	18770	27015	7730	439	3736	(2) 5,5	4770	(2) 300	22255	4632	2746	1886	781	11036
XE1157E	(2) 15	84,6	23750	32395	10220	652	5542	(2) 5,5	4770	(2) 300	27635	5064	3178	1886	1213	11036
XC1210E	(2) 22	98,3	21230	29675	8960	545	4639	(2) 5,5	4770	(2) 300	24910	4848	2962	1886	997	11036
XC1222E	(2) 30	109,8	18915	27160	7800	439	3736	(2) 5,5	4770	(2) 300	22400	4632	2746	1886	781	11036
XC1264E	(2) 22	96,8	23825	32470	10255	652	5542	(2) 5,5	4770	(2) 300	27705	5064	3178	1886	1213	11036
XC1282E	(2) 30	108,2	21375	29820	9030	545	4639	(2) 5,5	4770	(2) 300	25055	4848	2962	1886	997	11036
XC1340E	(2) 30	106,6	23970	32615	10330	652	5542	(2) 5,5	4770	(2) 300	27850	5064	3178	1886	1213	11036

The motors are shipped loose for field mounting.

† Heaviest section is the coil / fan section

†† When a remote sump arrangement is selected, the spray pump, suction strainer and associated piping are omitted; the unit is provided with an oversized outlet to facilitate drainage to the remote sump

* Liters shown is water in suspension in unit and piping. Allow for additional water in bottom of remote sump to cover pump suction and strainer during operation. (300mm would normally be sufficient).

** Refrigerant charge is shown for R-717. Multiply by 1.93 for R22, 1.98 for R134A and 1.7 for R404A, R410A and R507A.

Δ Unit dimensions and coil connections may vary slightly from catalog. See factory certified prints for dimensions, quantity of coil connections, and piping configuration. Coil connections are 4" bevel for weld (BFW).

ΔΔ Q is 485 mm for 4 kW pumps, 660 mm for 5 and 7,5 kW pumps.

ATC-E

ENGINEERING DATA & DIMENSIONS

MODELS: 428E TO 967E

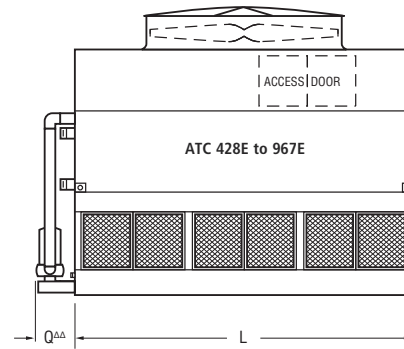
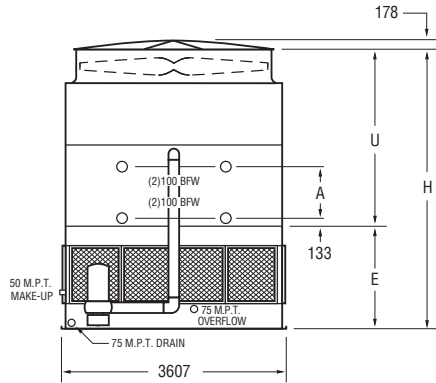

Optional Dual Fan units will have a "-DF" at the end of the model number. Fan kW and weights may vary.

ATC-E Model No.	Fans		Weights (kg)			Refrigerant Operating Charge** (kg)	Coil Volume (l)	Spray Pump kW	Remote Sump††			Dimensions ^Δ (mm)				
	kW	m ³ /s	Shipping	Operating	Heaviest Section†				Liters Req'd*	Conn. Size(mm)	Operating Weight	Height H	Upper U	Lower E	Coil A	Length L
428E	11	34,8	7510	10595	6280	182	1548	4	1855	300	8805	4328	2746	1581	781	3651
456E	15	38,3	7540	10625	6310	182	1548	4	1855	300	8830	4328	2746	1581	781	3651
474E	18,5	40,9	7550	10635	6325	182	1548	4	1855	300	8845	4328	2746	1581	781	3651
503E	15	37,2	8530	11695	7300	225	1917	4	1855	300	9900	4543	2962	1581	997	3651
523E	5	39,6	8540	11705	7310	225	1917	4	1855	300	9915	4543	2962	1581	997	3651
539E	22	41,8	8565	11730	7335	225	1917	4	1855	300	9940	4543	2962	1581	997	3651
559E	22	40,4	9635	12880	8405	269	2286	4	1855	300	11090	4759	3178	1581	1213	3651
583E	30	43,8	9705	12955	8480	269	2286	4	1855	300	11165	4759	3178	1581	1213	3651
545E	22	48,1	8590	12220	7205	212	1799	4	2160	300	10145	4480	2746	1734	781	4261
556E	15	41,2	9690	13415	8300	262	2231	4	2160	300	11345	4696	2962	1734	997	4261
581E	18,5	44,4	9700	13430	8315	262	2231	4	2160	300	11360	4696	2962	1734	997	4261
601E	18,5	43,0	11065	14885	9675	313	2662	4	2160	300	12815	4912	3178	1734	1213	4261
620E	22	45,2	11085	14910	9700	313	2662	4	2160	300	12835	4912	3178	1734	1213	4261
647E	30	49,0	11160	14980	9770	313	2662	4	2160	300	12910	4912	3178	1734	1213	4261
642E	15	51,9	10745	15390	8970	271	2301	5,5	2725	300	12730	4632	2746	1886	781	5486
682E	18,5	55,9	10760	15405	8980	271	2301	5,5	2725	300	12740	4632	2746	1886	781	5486
713E	22	59,5	10780	15425	9005	271	2301	5,5	2725	300	12765	4632	2746	1886	781	5486
747E	18,5	54,2	12255	17030	10480	336	2858	5,5	2725	300	14365	4848	2962	1886	997	5486
781E	22	57,6	12280	17050	10500	336	2858	5,5	2725	300	14390	4848	2962	1886	997	5486
806E	22	55,9	13815	18715	12040	402	3416	5,5	2725	300	16055	5064	3178	1886	1213	5486
827E	30	62,6	12350	17125	10575	336	2858	5,5	2725	300	14460	4848	2962	1886	997	5486
854E	30	60,6	13890	18790	12110	402	3416	5,5	2725	300	16125	5064	3178	1886	1213	5486
892E	37	64,5	13895	18790	12115	402	3416	5,5	2725	300	16130	5064	3178	1886	1213	5486
791E	30	69,7	11950	17165	9905	300	2552	7,5	3030	350	14125	4632	2746	1886	781	6096
816E	22	61,9	13550	18895	11505	373	3172	7,5	3030	350	15860	4848	2962	1886	997	6096
842E	22	59,9	15430	20920	13385	446	3792	7,5	3030	350	17880	5064	3178	1886	1213	6096
869E	30	67,6	13620	18970	11575	373	3172	7,5	3030	350	15930	4848	2962	1886	997	6096
907E	37	71,9	13625	18975	11580	373	3172	7,5	3030	350	15935	4848	2962	1886	997	6096
935E	37	69,7	15510	20995	13465	446	3792	7,5	3030	350	17960	5064	3178	1886	1213	6096
967E	45	73,3	15600	21090	13555	446	3792	7,5	3030	350	18050	5064	3178	1886	1213	6096

The motors are shipped loose for field mounting.

† Heaviest section is the coil / fan section

†† When a remote sump arrangement is selected, the spray pump, suction strainer and associated piping are omitted; the unit is provided with an oversized outlet to facilitate drainage to the remote sump

* Liters shown is water in suspension in unit and piping. Allow for additional water in bottom of remote sump to cover pump suction and strainer during operation. (300mm would normally be sufficient).

** Refrigerant charge is shown for R-717. Multiply by 1.93 for R22, 1.98 for R134A and 1.7 for R404A, R410A and R507A.

Δ Unit dimensions and coil connections may vary slightly from catalog. See factory certified prints for dimensions, quantity of coil connections, and piping configuration.

Coil connections are 4" bevel for weld (BFW).

ΔΔ Q is 485 mm for 4 kW pumps, 660 mm for 5 and 7,5 kW pumps.

ENGINEERING DATA & DIMENSIONS

ATC-E

MODELS: 858E TO 1925E

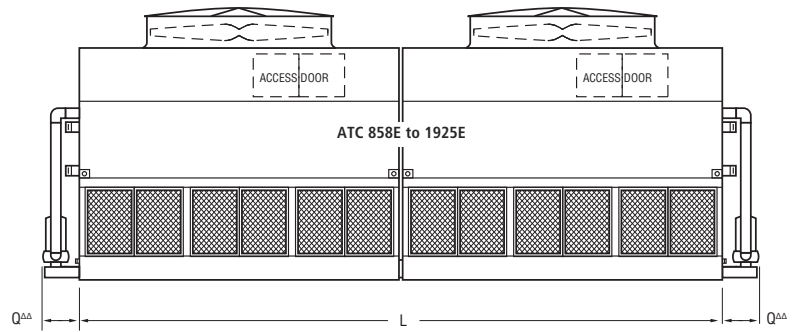
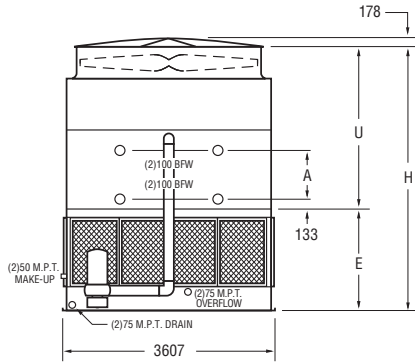

ENGINEERING

Optional Dual Fan units will have a "-DF" at the end of the model number. Fan kW and weights may vary.

ATC-E Model No.	Fans		Weights (kg)			Refrigerant Operating Charge** (kg)	Coil Volume (l)	Spray Pump kW	Remote Sump††			Dimensions ^Δ (mm)				
	kW	m ³ /s	Shipping	Operating	Heaviest Section†				Liters Req'd*	Conn. Size(mm)	Operating Weight	Height H	Upper U	Lower E	Coil A	Length L
858E	(2) 11	69,7	15025	21190	6280	364	3096	(2) 4	3710	(2) 300	17610	4632	2746	1886	781	7366
913E	(2) 15	76,7	15075	21245	6310	364	3096	(2) 4	3710	(2) 300	17665	4632	2746	1886	781	7366
949E	(2) 18,5	81,7	15105	21275	6325	364	3096	(2) 4	3710	(2) 300	17690	4632	2746	1886	781	7366
980E	(2) 11	65,6	19140	25635	8340	538	4571	(2) 4	3710	(2) 300	22055	5064	3178	1886	1213	7366
1007E	(2) 15	74,5	17055	23385	7300	451	3834	(2) 4	3710	(2) 300	19805	4848	2962	1886	997	7366
1047E	(2) 18,5	79,3	17080	23415	7310	451	3834	(2) 4	3710	(2) 300	19830	4848	2962	1886	997	7366
1078E	(2) 22	83,5	17130	23460	7335	451	3834	(2) 4	3710	(2) 300	19875	4848	2962	1886	997	7366
1085E	(2) 18,5	76,8	19225	25720	8380	538	4571	(2) 4	3710	(2) 300	22135	5064	3178	1886	1213	7366
1118E	(2) 22	80,9	19270	25765	8405	538	4571	(2) 4	3710	(2) 300	22180	5064	3178	1886	1213	7366
1167E	(2) 30	87,6	19415	25910	8480	538	4571	(2) 4	3710	(2) 300	22325	5064	3178	1886	1213	7366
1164E	(2) 18,5	88,7	19405	26860	8315	525	4462	(2) 4	4315	(2) 300	22715	5153	2962	2191	997	8585
1204E	(2) 18,5	85,9	22125	29775	9675	626	5325	(2) 4	4315	(2) 300	25630	5369	3178	2191	1213	8585
1240E	(2) 22	90,4	22170	29820	9700	626	5325	(2) 4	4315	(2) 300	25675	5369	3178	2191	1213	8585
1294E	(2) 30	98,0	22315	29965	9770	626	5325	(2) 4	4315	(2) 300	25820	5369	3178	2191	1213	8585
1192E	(2) 22	122,5	18450	27490	7450	410	3489	(2) 5,5	5450	(2) 300	22165	4721	2530	2191	565	11036
1284E	(2) 15	103,9	21490	30780	8970	541	4603	(2) 5,5	5450	(2) 300	25455	4937	2746	2191	781	11036
1365E	(2) 18,5	111,7	21520	30810	8980	541	4603	(2) 5,5	5450	(2) 300	25485	4937	2746	2191	781	11036
1426E	(2) 22	118,9	21565	30855	9005	541	4603	(2) 5,5	5450	(2) 300	25530	4937	2746	2191	781	11036
1496E	(2) 18,5	108,5	24510	34055	10480	672	5717	(2) 5,5	5450	(2) 300	28730	5153	2962	2191	997	11036
1562E	(2) 22	115,2	24555	34100	10500	672	5717	(2) 5,5	5450	(2) 300	28775	5153	2962	2191	997	11036
1655E	(2) 30	125,1	24705	34245	10575	672	5717	(2) 5,5	5450	(2) 300	28920	5153	2962	2191	997	11036
1709E	(2) 30	121,2	27780	37575	12110	803	6831	(2) 5,5	5450	(2) 300	32250	5369	3178	2191	1213	11036
1784E	(2) 37	129,0	27785	37585	12115	803	6831	(2) 5,5	5450	(2) 300	32260	5369	3178	2191	1213	11036
1625E	(2) 22	123,7	27100	37795	11505	746	6345	(2) 7,5	6055	(2) 350	31715	5153	2962	2191	997	12256
1729E	(2) 30	135,2	27245	37940	11575	746	6345	(2) 7,5	6055	(2) 350	31860	5153	2962	2191	997	12256
1805E	(2) 37	143,8	27250	37950	11580	746	6345	(2) 7,5	6055	(2) 350	31870	5153	2962	2191	997	12256
1861E	(2) 37	139,3	31015	41995	13465	892	7584	(2) 7,5	6055	(2) 350	35915	5369	3178	2191	1213	12256
1925E	(2) 45	146,6	31200	42175	13555	892	7584	(2) 7,5	6055	(2) 350	36095	5369	3178	2191	1213	12256

The motors are shipped loose for field mounting.

† Heaviest section is the coil / fan section

†† When a remote sump arrangement is selected, the spray pump, suction strainer and associated piping are omitted; the unit is provided with an oversized outlet to facilitate drainage to the remote sump

* Liters shown is water in suspension in unit and piping. Allow for additional water in bottom of remote sump to cover pump suction and strainer during operation. (300mm would normally be sufficient).

** Refrigerant charge is shown for R-717. Multiply by 1.93 for R22, 1.98 for R134A and 1.7 for R404A, R410A and R507A.

Δ Unit dimensions and coil connections may vary slightly from catalog. See factory certified prints for dimensions, quantity of coil connections, and piping configuration.

Coil connections are 4" bevel for weld (BFW).

ΔΔ Q is 485 mm for 4 kW pumps, 660 mm for 5 and 7,5 kW pumps.

ATC-E

ENGINEERING DATA & DIMENSIONS

MODELS: 857E TO 1915E

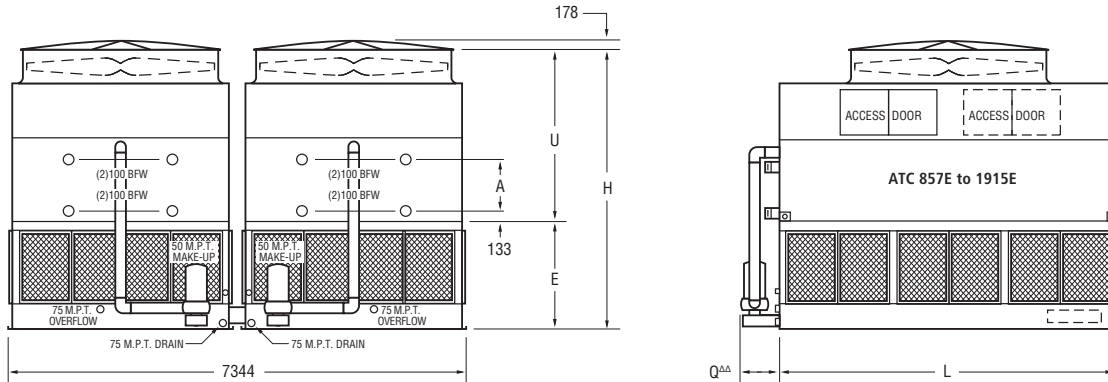

Optional Dual Fan units will have a "-DF" at the end of the model number. Fan kW and weights may vary.

ATC-E Model No.	Fans		Weights (kg)			Refrigerant Operating Charge** (kg)	Coil Volume (l)	Spray Pump kW	Remote Sump††			Dimensions ^Δ (mm)				
	kW	m ³ /s	Shipping	Operating	Heaviest Section†				Liters Req'd*	Conn. Size(mm)	Operating Weight	Height H	Upper U	Lower E	Coil A	Length L
857E	(2) 11	69,7	15025	21190	6280	364	3096	(2) 4	3710	(2) 300	17610	4632	2746	1886	781	3651
912E	(2) 15	76,7	15075	21245	6310	364	3096	(2) 4	3710	(2) 300	17665	4632	2746	1886	781	3651
979E	(2) 11	65,6	19140	25635	8340	538	4572	(2) 4	3710	(2) 300	22055	5064	3178	1886	1213	3651
1006E	(2) 15	74,5	17055	23385	7300	451	3834	(2) 4	3710	(2) 300	19805	4848	2962	1886	997	3651
1046E	(2) 18,5	79,3	17080	23415	7310	451	3834	(2) 4	3710	(2) 300	19830	4848	2962	1886	997	3651
1077E	(2) 22	83,5	17130	23460	7335	451	3834	(2) 4	3710	(2) 300	19875	4848	2962	1886	997	3651
1117E	(2) 22	80,9	19270	25765	8405	538	4571	(2) 4	3710	(2) 300	22180	5064	3178	1886	1213	3651
1166E	(2) 30	87,6	19415	25910	8480	538	4571	(2) 4	3710	(2) 300	22325	5064	3178	1886	1213	3651
1163E	(2) 18,5	88,7	19405	26860	8315	525	4462	(2) 4	4315	(2) 300	22715	5153	2962	2191	997	4261
1203E	(2) 18,5	85,9	22125	29775	9675	626	5325	(2) 4	4315	(2) 300	25630	5369	3178	2191	1213	4261
1239E	(2) 22	90,4	22170	29820	9700	626	5325	(2) 4	4315	(2) 300	25675	5369	3178	2191	1213	4261
1293E	(2) 30	98,0	22315	29965	9770	626	5325	(2) 4	4315	(2) 300	25820	5369	3178	2191	1213	4261
1191E	(2) 22	122,5	18450	27490	7450	410	3489	(2) 5,5	5450	(2) 300	22165	5026	2530	2496	565	5486
1283E	(2) 15	103,9	21490	30780	8970	541	4603	(2) 5,5	5450	(2) 300	25455	5242	2746	2496	781	5486
1364E	(2) 18,5	111,7	21520	30810	8980	541	4603	(2) 5,5	5450	(2) 300	25485	5242	2746	2496	781	5486
1425E	(2) 22	118,9	21565	30855	9005	541	4603	(2) 5,5	5450	(2) 300	25530	5242	2746	2496	781	5486
1495E	(2) 18,5	108,5	24510	34055	10480	672	5717	(2) 5,5	5450	(2) 300	28730	5458	2962	2496	997	5486
1561E	(2) 22	115,2	24555	34100	10500	672	5717	(2) 5,5	5450	(2) 300	28775	5458	2962	2496	997	5486
1654E	(2) 30	125,1	24705	34245	10575	672	5717	(2) 5,5	5450	(2) 300	28920	5458	2962	2496	997	5486
1708E	(2) 30	121,2	27780	37575	12110	803	6831	(2) 5,5	5450	(2) 300	32250	5674	3178	2496	1213	5486
1783E	(2) 37	129,0	27785	37585	12115	803	6831	(2) 5,5	5450	(2) 300	32260	5674	3178	2496	1213	5486
1616E	(2) 22	123,1	27100	37795	11505	746	6345	(2) 7,5	6055	(2) 350	31715	5458	2962	2496	997	6096
1720E	(2) 30	134,5	27245	37940	11575	746	6345	(2) 7,5	6055	(2) 350	31860	5458	2962	2496	997	6096
1795E	(2) 37	143,1	27250	37950	11580	746	6345	(2) 7,5	6055	(2) 350	31870	5458	2962	2496	997	6096
1851E	(2) 37	138,6	31015	41995	13465	892	7584	(2) 7,5	6055	(2) 350	35915	5674	3178	2496	1213	6096
1915E	(2) 45	145,9	31200	42175	13555	892	7584	(2) 7,5	6055	(2) 350	36095	5674	3178	2496	1213	6096

The motors are shipped loose for field mounting.

† Heaviest section is the coil / fan section

†† When a remote sump arrangement is selected, the spray pump, suction strainer and associated piping are omitted; the unit is provided with an oversized outlet to facilitate drainage to the remote sump

* Liters shown is water in suspension in unit and piping. Allow for additional water in bottom of remote sump to cover pump suction and strainer during operation. (300mm would normally be sufficient).

** Refrigerant charge is shown for R-717. Multiply by 1.93 for R22, 1.98 for R134A and 1.7 for R404A, R410A and R507A.

Δ Unit dimensions and coil connections may vary slightly from catalog. See factory certified prints for dimensions, quantity of coil connections, and piping configuration. Coil connections are 4" bevel for weld (BFW).

ΔΔ Q is 485 mm for 4 kW pumps, 660 mm for 5 and 7,5 kW pumps.

ENGINEERING DATA & DIMENSIONS

ATC-E

MODELS: 1879E TO 3714E

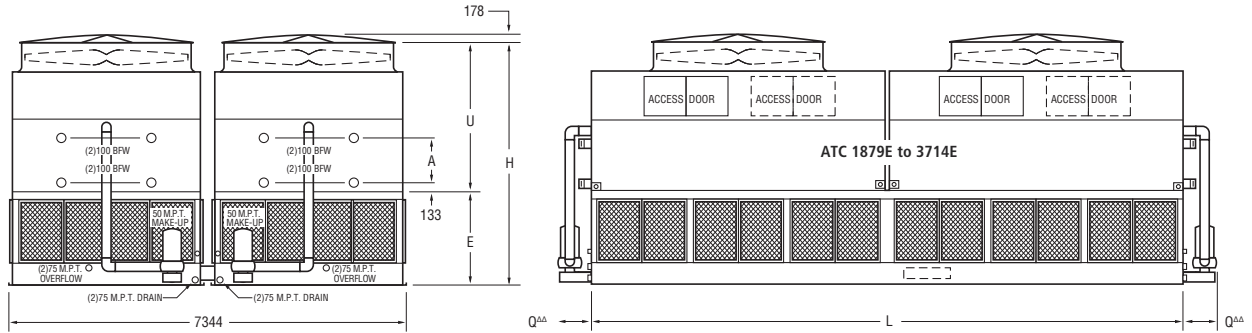

Optional Dual Fan units will have a "-DF" at the end of the model number. Fan kW and weights may vary.

ATC-E Model No.	Fans		Weights (kg)			Refrigerant Operating Charge** (kg)	Coil Volume (l)	Spray Pump kW	Remote Sump††			Dimensions ^Δ (mm)				
	kW	m ³ /s	Shipping	Operating	Heaviest Section†				Liters Req'd*	Conn. Size(mm)	Operating Weight	Height H	Upper U	Lower E	Coil A	Length L
1879E	(4) 11	135,3	34155	46830	7270	902	7668	(4) 4	7420	(4) 300	39545	5458	2962	2496	997	7366
2002E	(4) 15	148,9	34265	46940	7300	902	7668	(4) 4	7420	(4) 300	39655	5458	2962	2496	997	7366
2082E	(4) 18,5	158,6	34320	46990	7310	902	7668	(4) 4	7420	(4) 300	39705	5458	2962	2496	997	7366
2158E	(4) 18,5	153,6	38600	51600	8380	1075	9143	(4) 4	7420	(4) 300	44315	5674	3178	2496	1213	7366
2223E	(4) 22	161,8	38690	51690	8405	1075	9143	(4) 4	7420	(4) 300	44405	5674	3178	2496	1213	7366
2320E	(4) 30	175,3	38980	51980	8480	1075	9143	(4) 4	7420	(4) 300	44695	5674	3178	2496	1213	7366
2256E	(4) 18,5	174,7	38900	53880	8315	1049	8923	(4) 4	8630	(4) 300	45460	5458	2962	2496	997	8585
2324E	(4) 22	183,8	38990	53970	8335	1049	8923	(4) 4	8630	(4) 300	45550	5458	2962	2496	997	8585
2404E	(4) 22	178,2	44435	59795	9700	1252	10649	(4) 4	8630	(4) 300	51375	5674	3178	2496	1213	8585
2509E	(4) 30	193,0	44725	60085	9770	1252	10649	(4) 4	8630	(4) 300	51665	5674	3178	2496	1213	8585
2490E	(4) 15	204,7	43255	61925	8970	1082	9205	(4) 5,5	10900	(4) 300	51140	5242	2746	2496	781	11036
2647E	(4) 18,5	220,1	43310	61980	8980	1082	9205	(4) 5,5	10900	(4) 300	51190	5242	2746	2496	781	11036
2765E	(4) 22	234,3	43400	62070	9005	1082	9205	(4) 5,5	10900	(4) 300	51285	5242	2746	2496	781	11036
2900E	(4) 18,5	213,6	49295	68475	10480	1345	11434	(4) 5,5	10900	(4) 300	57690	5458	2962	2496	997	11036
3029E	(4) 22	227,0	49385	68565	10500	1345	11434	(4) 5,5	10900	(4) 300	57780	5458	2962	2496	997	11036
3210E	(4) 30	246,5	49675	68855	10575	1345	11434	(4) 5,5	10900	(4) 300	58070	5458	2962	2496	997	11036
3313E	(4) 30	238,8	55830	75515	12110	1607	13662	(4) 5,5	10900	(4) 300	64730	5674	3178	2496	1213	11036
3459E	(4) 37	254,2	55845	75530	12115	1607	13662	(4) 5,5	10900	(4) 300	64745	5674	3178	2496	1213	11036
2855E	(4) 22	250,1	47565	68490	9835	1201	10210	(4) 7,5	12115	(4) 350	56200	5242	2746	2496	781	12256
3232E	(4) 22	234,8	61770	83805	13385	1784	15169	(4) 7,5	12115	(4) 350	71515	5674	3178	2496	1213	12256
3336E	(4) 30	264,9	54530	76005	11575	1492	12689	(4) 7,5	12115	(4) 350	63710	5458	2962	2496	997	12256
3482E	(4) 37	281,9	54550	76020	11580	1492	12690	(4) 7,5	12115	(4) 350	63730	5458	2962	2496	997	12256
3591E	(4) 37	273,0	62080	84115	13465	1784	15169	(4) 7,5	12115	(4) 350	71820	5674	3178	2496	1213	12256
3714E	(4) 45	287,4	62440	84475	13555	1784	15169	(4) 7,5	12115	(4) 350	72185	5674	3178	2496	1213	12256

The motors are shipped loose for field mounting.

† Heaviest section is the coil / fan section

†† When a remote sump arrangement is selected, the spray pump, suction strainer and associated piping are omitted; the unit is provided with an oversized outlet to facilitate drainage to the remote sump

* Liters shown is water in suspension in unit and piping. Allow for additional water in bottom of remote sump to cover pump suction and strainer during operation. (300mm would normally be sufficient).

** Refrigerant charge is shown for R-717. Multiply by 1.93 for R22, 1.98 for R134A and 1.7 for R404A, R410A and R507A.

Δ Unit dimensions and coil connections may vary slightly from catalog. See factory certified prints for dimensions, quantity of coil connections, and piping configuration. Coil connections are 4" bevel for weld (BFW).

AA Q is 485 mm for 4 kW pumps, 660 mm for 5 and 7,5 kW pumps.

ATC-E

RECOMMENDED STEEL SUPPORT

The recommended support for EVAPCO condensers is structural "I" beams located under the outer flanges and running the entire length of the unit. Mounting holes, 19 mm in diameter are located in the bottom channels of the pan section to provide for bolting to the structural steel. (Refer to certified drawings from the factory for bolt hole locations.)

Beams should be level to within 3 mm per 2 m before setting the unit in place. Do not level the unit by shimming between it and the "I" beams as this will not provide proper longitudinal support.

Plan Views

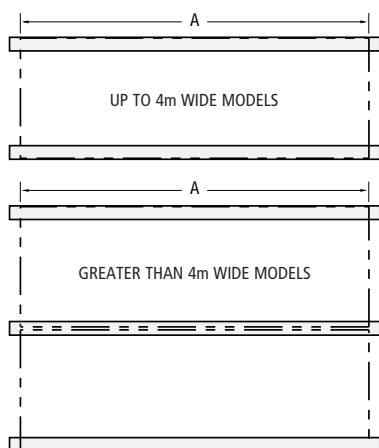

End Elevations

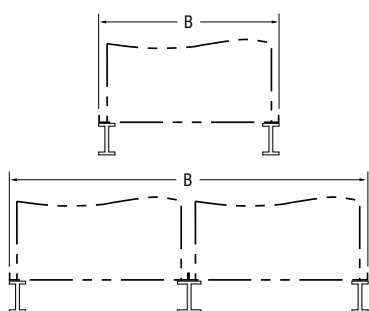

ATC-E DIMENSIONS

ATC-E DIMENSIONS		
Models	A	B
ATC-E 50E to 80E 90E to 120E 135E to 165E	1826	1226
	2731	1226
	3651	1226
ATC-E M170E to M247E M203E to M233E M252E to M331E M301E to M380E M337E to M439E M426E to M591E M523E to M679E M637E to M759E M674E to M877E M852E to M1179E M10468E to M1358E	2578	2283
	2731	2388
	3188	2388
	3651	2388
	4261	2388
	5486	2388
	6401	2388
	7366	2388
	8585	2388
	11036	2388
	12865	2388
ATC-E M501E to M658E M634E to M755E M712E to M844E	3188	4905
	3651	4905
	4261	4905
ATC-E XE298E to XC462E XE406E to XC669E XE596E to XC925E XE812E to XC1340E	3652	2991
	5487	2991
	7366	2991
	11037	2991
ATC-E 428E to 583E 545E to 647E 642E to 892E 791E to 967E 858E to 1167E 1164E to 1294E 1192E to 1784E 1625E to 1925E	3651	3607
	4261	3607
	5486	3607
	6096	3607
	7366	3607
	8585	3607
	11036	3607
	11036	3607
	12256	3607
ATC-E 857E to 1166E 1163E to 1293E 1191E to 1783E 1616E to 1915E 1879E to 2320E 2256E to 2509E 2490E to 3459E 2855E to 3714E	3651	7344
	4261	7344
	5486	7344
	6096	7344
	7366	7344
	8585	7344
	11036	7344
	11036	7344
	12256	7344
	12256	7344

SPECIFICATIONS

ATC-E

FACTORY FABRICATED INDUCED DRAFT ATC-E EVAPORATIVE CONDENSER

General

Furnish and install factory assembled evaporative condenser of induced draft counterflow design with a horizontal multiple side air entry and a vertical air discharge. The unit shall be completely factory assembled and conform to the specifications and schedules.

The condenser shall reject _____ kW of heat with _____ as refrigerant and _____ °C condensation temperature at a wet bulb temperature of _____ °C .

The total fan power should not exceed _____ kW.
The total pump power should not exceed _____ kW.

The total overall unit dimensions should not exceed the following:
Length: _____ mm Width: _____ mm Height: _____ mm

The maximum operating weight should not exceed _____ kg.

The unit will be delivered in two parts: the bottom basin - louver section and the heat transfer - fan section. The unit (top and bottom section) shall be joined together with elastic sealer and bolted together with corrosion resistant fasteners.

Approved manufacturer Evapco – model ATC-E _____

Thermal Performance – Performance Warranty

The tower shall be capable of performing the thermal duties as shown in the schedule and on drawings and its design thermal rating shall be guaranteed by the manufacturer.

Applicable Standards

CTI ATC 128 Test Code for Measurement of Sound from Water Cooling Towers

Submittals

- The manufacturer shall submit a five year history of the proposed type of evaporative condenser with a minimum of 10 installations for similar sized equipment.
- Shop drawings: submit shop drawings indicating dimensions, weight loadings and required clearances.
- Product data: submit manufacturers technical product data, original selection printouts and clearance requirements.
- Complete noise data sheet for the selected evaporative condenser(s).
- Maintenance data for the evaporative condenser(s) and accessories.
- The manufacturer shall provide factory test run certificates of the fans and fan motor.

Product Delivery – Storage and Handling

- The contractor shall make the provisions for proper storage at site before installation and handle the product per the instructions of the manufacturer.
- Once installed provide the necessary measures to keep units clean and protected from any dust and mechanical damage.

Quality Assurance

- The manufacturer shall have a quality assurance system in place which is certified by an accredited registrar and complying with the requirements of ISO 9001. This is to guarantee a consistent level of product and service quality.
- Manufacturers without ISO 9001 certification are not acceptable.

Warranty

- The products will be warranted for a period of minimum two years from the date of shipment.

PRODUCT

Construction – Corrosion Resistance

- The structure and all steel elements of the pan and casing shall be constructed of Z 725 hot dip galvanized steel for long life and durability. Alternatives with lower zinc layer thickness and external paint or coating are not accepted as equal.
- The strainer shall be made of stainless steel type 304.
- During fabrication all panel edges shall be coated with a 95% pure zinc compound.
- Casing materials shall be of non flammable construction only.

OPTIONAL EXECUTION – BASIN IN AISI 304

Construction – Corrosion Resistance

- The structure and all steel elements of the Basin and Louver section up to the water level shall be made of stainless steel AISI 304. Cold water basin will be a welded stainless steel construction.
- Alternatives with hot dip galvanized steel and epoxy coatings in lieu of the stainless steel AISI 304 are not considered to be equal and are not accepted.
- All other steel components of the casing shall be constructed of Z 725 hot dip galvanized steel for long life and durability. Alternatives with lower zinc layer thickness and external paint or coating or FRP materials are not accepted as equal.
- The strainer shall be made of stainless steel AISI 304.
- During fabrication all galvanized steel panel edges shall be coated with a 95 % pure zinc compound.
- Casing materials shall be of non flammable construction only.

OPTIONAL EXECUTION – COMPLETE UNIT IN

STAINLESS STEEL AISI 304 (except heat exchange coil(s))

Construction – Corrosion Resistance

- The structure and all steel elements shall be made of AISI 304. Cold water basin will be a welded stainless steel construction.
- Alternatives with hot dip galvanized steel and epoxy coatings in lieu of the AISI 304 are not considered to be equal and are not accepted.
- The strainer shall be made of stainless steel AISI 304.
- Casing materials shall be of non flammable construction only.

Evaporative Condenser Basin

- Standard basin accessories include: overflow, drain, strainer and brass make up valve with plastic float ball.
- The strainer shall be made of AISI 304.
- The entire pan area shall incorporate a sloped and stepped basin design to prevent sediment built up, biological film and standing water.
- Upper and lower basin bottoms shall be sloped to provide drainage of the complete basin section.
- The basin can be inspected while the unit is in operation with the fan(s) and pump(s) running.

Air Inlet Louvers

- The air inlet louvers shall be constructed of UV inhibited polyvinyl chloride (PVC), mounted in easily removable frames for easy access to the basin.
- The louvers shall be at four sides to provide easy access to the basin interior.
- The louvers shall have a minimum of two changes in air direction to prevent splash out and block direct sunlight from entering the basin.
- The louvers will have a 19 mm opening to prevent debris from entering the basin.

Casing Section

Heat Transfer Coil

- The evaporative condenser shall use internally enhanced heat exchange coils of an elliptical tube design to obtain lower air flow resistance and allow higher water loadings around the tubes.

ATC-E

SPECIFICATIONS

- b) The heat transfer coil(s) shall be made of all prime surface, encased in a steel framework and hot dip galvanized after fabrication as a complete assembly.
- c) The tubes shall be arranged in a self spacing, staggered pattern in the direction of air flow for maximum heat transfer efficiency and minimum pressure drop.
- d) The heat exchange coils shall be air pressure tested under water.
- e) The design and manufacturing process shall be approved and in accordance with the "Pressure Equipment Directive " – PED 97 / 23 EC.
- f) The manufacturer shall be responsible for the manufacturing and performance testing of the entire heat transfer coil. This is to assure single source responsibility.
- g) The casing shall totally encase the complete coil section to protect the complete coil from direct atmospheric contact.

Water Distribution

- a) The water distribution system shall be completely enclosed and protected from sunlight exposure, environmental elements and debris. Water distribution systems with direct exposure to the environment are not allowed.
- b) The spray header and branches shall be constructed of Schedule 40, Polyvinyl Chloride (PVC) pipe for corrosion resistance.
- c) The water shall be distributed over the coil by precision molded ZM II™ spray nozzles with large minimum orifice openings and integral sludge ring to eliminate clogging.
- d) The nozzles shall be threaded into the water distribution piping to assure positive positioning and easy removal for maintenance. Snap in or strapped on nozzles are not accepted.

Water Circulation Pump

- a) The pump(s) shall be a close coupled , centrifugal type with mechanical seal , installed vertically at the factory to allow free drainage on shut down.
- b) A ___ kW totally enclosed motor(s) suitable for outdoor service shall be furnished.
- c) The motor shall be suitable for the following power supply: ___volts, ___hertz and ___ phase and ___ kW.

Drift Eliminators

- a) The drift eliminators shall be constructed of entirely inert polyvinyl (PVC) that has been specially treated to resist ultra violet light.
- b) Assembled in easily handled sections, the eliminator blades shall be spaced on 25 mm centers and shall incorporate three changes in air direction to assure efficient removal of entrained moisture from the discharge air stream.
- c) The maximum drift rate shall not exceed 0,001 % of the circulating water rate.
- d) The drift eliminators shall be Eurovent OM-14-2009 certified.

Access Door

- a) A large hinged access door shall provide access to the fan section for maintenance.

Mechanical Equipment

Axial Propeller Fan(s) (Standard)

- a) Fan shall be heavy duty wide chord axial propeller type, statically balanced and constructed of extruded aluminum alloy blades.
- b) Fans shall be installed in a closely fitted cowl with venturi air inlet for maximum fan efficiency.
- c) The fans shall utilize a soft connect blade to hub design, compatible with variable speed drives, to avoid transmission of vertical forces to the unit structure.
- d) Each fan blade shall be individually adjustable.
- e) The fan cowl shall be covered with a heavy gauge hot dip galvanized steel wire fan guard.

- f) The fan – drive system (fan – drive – motor) shall be factory mounted, adjusted and undergo a trial run in the factory before shipment.

Axial Propeller Fan(s) - Low Sound Fan (Alternative)

- a) Fan shall be heavy duty wide chord axial propeller type, statically balanced and constructed of extruded aluminum alloy blades.
- b) Fans shall be installed in a closely fitted cowl with venturi air inlet for maximum fan efficiency.
- c) The fans shall utilize a soft connect blade to hub design, compatible with variable speed drives, to avoid transmission of vertical forces to the unit structure.
- d) Each fan blade shall be individually adjustable.
- e) The fan cowl shall be covered with a heavy gauge hot dip galvanized steel wire fan guard.
- f) The fan – drive system (fan – drive – motor) shall be factory mounted, adjusted and undergo a trial run in the factory before shipment.

Axial Propeller Fan(s) - Super Low Sound Fan (Alternative)

- a) Fan shall be extremely wide chord axial, one piece heavy duty propeller type, statically balanced and made of FRP.
- b) Fans will be installed in a closely fitted cowl with venturi air inlet for maximum fan efficiency.
- c) The fan cowl shall be covered with a heavy gauge hot dip galvanized steel wire fan guard.
- d) The fan – drive system (fan – drive – motor) shall be factory mounted, adjusted and undergo a trial run in the factory before shipment.
- e) The fans are high efficiency and operate with no loss of thermal performance

Bearings and Drive

- a) The fan shaft (s) shall be supported by heavy duty, self aligning ball type bearings with cast iron housings.
- b) The bearings shall be rated for an L-10 life of 75000 hours.
- c) The fan drive sheaves shall be aluminum alloy.
- d) The belt shall be a multigroove belt system, constructed of neoprene with polyester cords and designed for 150% of the motor nameplate horsepower.
- e) The grease fittings shall be extended to a location just inside the access door.

Motor (1.2 and 2.4 meter wide Models)

- a) The fan motor shall be Totally Enclosed Fan Cooled (TEFC), squirrel cage, ball bearing type motor.
- b) The motor shall be specially designed for cooling tower use with moisture protection on the winding, shaft and bearings.
- c) The motor shall be minimum IP 55 degree of protection, Class F insulation, Service Factor 1 and selected for the appropriate cooling tower duty and the correct ambient temperature but minimum 40°C.
- d) Motors bearings shall be double sealed non-relubricable or external grease nipples shall be provided.
- e) The motor shall be mounted on an adjustable heavy duty steel motor base.
- f) A hinged protective cover shall shield the motor and sheave from the weather.
- g) The motor power supply shall be ___ volts, ___ hertz and ___ phase.

Motor (3 and 3.6 meter wide Models)

- a) The fan motor shall be Totally Enclosed Air Over (TEAO), squirrel cage, ball bearing type motor.
- b) The motor shall be specially designed for cooling tower use with moisture protection on the windings, shaft and bearings.
- c) The motor shall be minimum IP 55 degree of protection, Class F insulation, Service Factor 1 and selected for the appropriate cooling tower duty and the correct ambient temperature but minimum 40°C.
- d) Motor bearings shall be double sealed non-relubricable or external grease nipples shall be provided.
- e) The motor shall be mounted on an adjustable heavy

ATC-E

SPECIFICATIONS

- f) duty steel motor base.
- f) The motor base shall be able to swing to the outside of the unit for repair or removal.
- g) The motor power supply shall be ___ volts, ___ hertz and ___ phase.

Sound Levels

Sound Level

The maximum sound pressure levels (dB) measured 1.5 m 45° from the top of the evaporative condenser operating at full fan speed shall not exceed the sound levels detailed below.

Location	63 Hz	125 Hz	250 Hz	500 Hz	1000 Hz	2000 Hz	4000 Hz	8000 Hz	dB(A)
Fan discharge									
Air inlet / end									

ACCESSORIES (Optional)

Electric Heaters

- a) The evaporative condenser cold water basin shall be provided with an electric heater package to prevent freezing of the water in the cold water basin, when the pump is shut down.
- b) The electric heater package includes: electric heater element(s), thermostat and low water level cutoff.
- c) The heaters shall be selected to maintain 4 °C basin water temperature at ___ °C ambient
- d) The heater(s) shall be ___ V / ___ phase / ___ Hz electric power supply.

Three Probe Electric Water Level Control Package

- a) The evaporative condenser manufacturer shall provide an electric water level control package instead of the mechanical float valve arrangement.
- b) The package consist of the following elements :
 - Multiple heavy duty stainless steel 316 static sensors mounted in a stilling chamber outside the unit. Electrodes or sensors mounted inside the unit are not accepted as their operation will be disturbed by the moving water in the basin.
 - An ABS, IP 56 case contains all the contactors for the different level probes and will provide an output signal of a relay for automatic filling and one relay for alarm level.
 - The power supply to the control package is 24 Vac / 230 Vac - ___ Hz .
 - A weather protected solenoid valve (PN16) for the water make up ready for piping to a water supply with pressure between 140 kPa and 340 kPa.

Vibration Switch

- a) A vibration limit switch shall be installed on the mechanical equipment support and wired into the control panel. The purpose of this switch is to interrupt power to the motor in the event of excessive vibration.
- b) The switch shall be adjustable for sensitivity and shall require manual reset.

Service Platform

- a) The evaporative condenser shall be supplied with an external service platform.
- b) The external service platform will be self supporting and include access ladders and safety cage to the platform.
- c) The external service platform will be installed in front of the fan access doors.
- d) The platform shall meet OSHA - CE requirements.

Motor Davit

- a) The evaporative condenser shall be supplied with a motor davit to facilitate the removal of fan motor(s) and fan(s).
- b) The davit and braket are constructed of aluminum and are mounted on the side of the unit.
- c) The fan motor davit ships loose with the unit and is installed in the field.

Water Silencer

- a) The water silencers are located in the falling water area of the cold water basin.
- b) The water silencers will reduce the overall sound levels 4 dB (A) to 7 dB (A) measured at 1.5 m from the side or end of the unit, when the fans are running, and 9 dB (A) to 12 dB (A) when fans are off.
- c) The water silencers are constructed of lightweight PVC sections and can be easily removed for access to the basin area.
- d) The water silencers will have no impact on the unit's thermal performance.



 World Headquarters/
Research and
Development Center

 EVAPCO Manufacturing
Locations

EVAPCO, Inc. - World Headquarters & Research / Development Center

P.O. Box 1300 • Westminster, MD 21158 USA
Ph: +1 410-756-2600 • Fx: +1 410-756-6450 • marketing@evapco.com

North America

EVAPCO, Inc.
World Headquarters
P.O. Box 1300
Westminster, MD 21158 USA
Ph: 410-756-2600 - Fx: 410-756-6450
marketing@evapco.com

EVAPCO East
5151 Allendale Lane
Taneytown, MD 21787 USA
Ph: 410-756-2600 - Fx: 410-756-6450
marketing@evapco.com

EVAPCO Midwest
1723 York Road
Greenup, IL 62428 USA
Ph: 217-923-3431 - Fx: 217-923-3300
evapcomw@evapcomw.com

EVAPCO West
1900 West Almond Avenue
Madera, CA 93637 USA
Ph: 559-673-2207 - Fx: 559-673-2378
contact@evapcowest.com

EVAPCO Iowa
925 Quality Drive
Lake View, IA 51450 USA
Ph: 712-657-3223 - Fx: 712-657-3226

**EVAPCO Iowa
Sales & Engineering**
215 1st Street, NE
P.O. Box 88
Medford, MN 55049 USA
Ph: 507-446-8005 - Fx: 507-446-8239
evapcomn@evapcomn.com

EVAPCO Newton
701 East Jourdan Street
Newton, IL 62448 USA
Ph: 618-783-3433 - Fx: 618-783-3499
evapcomw@evapcomw.com

EVAPCOLD
521 Evapco Drive
Greenup, IL 62428 USA
Ph: 217-923-3431
evapcomw@evapcomw.com

EVAPCO-Dry Cooling, Inc.
981 US Highway 22 West
Bridgewater, NJ 08807 USA
Ph: 1-908-379-2665
info@evapco-blct.com

**Refrigeration Valves &
Systems Corporation**
A wholly owned subsidiary of EVAPCO, Inc.
1520 Crosswind Dr.
Bryan, TX 77808 USA
Ph: 979-778-0095 - Fx: 979-778-0030
rvs@rvscorp.com

Evapco Northwest
5775 S.W. Jean Road, Suite 104
Lake Oswego, OR 97035 USA
Ph: 503-639-2137 - Fx: 503-639-1800

EvapTech, Inc.
A wholly owned subsidiary of EVAPCO, Inc.
8331 Nieman Road
Lenexa, KS 66214 USA
Ph: 913-322-5165 - Fx: 913-322-5166
marketing@evaptechinc.com

Tower Components, Inc.
A wholly owned subsidiary of EVAPCO, Inc.
5960 US HWY 64E
Ramseur, NC 27316
Ph: 336-824-2102 - Fx: 336-824-2190
mail@towercomponentsinc.com

South America

**Evapco Brasil
Equipamentos Industriais Ltda**
Rua Alexandre Dumas 1601
04717-004 Sao Paulo - SP - Brazil
Ph: (55) 11-5184-0067

Europe

**EVAPCO Europe BVBA
European Headquarters**
Heersterveldweg 19, Industrieterrein Oost
3700 Tongeren, Belgium
Ph: (32) 12-395029 - Fx: (32) 12-238527
evapco.europe@evapco.be

EVAPCO Europe, S.r.l.
Via Ciro Menotti 10
I-20017 Passirana di Rho, Milan, Italy
Ph: (39) 02-939-9041 - Fx: (39) 02-935-00840
evapcoeuropa@evapco.it

EVAPCO Europe, S.r.l.
Via Dosso 2 - 23020 Piateda Sondrio, Italy

EVAPCO Europe, GmbH
Insterburger Straße, 18
D-40670 Meerbusch, Germany
Ph: (49) 2159-69560 - Fx: (49) 2159-695611
info@evapco.de

EVAPCO Middle East DMCC
Reef Tower, 29th Level, Cluster O,
Jumeirah Lake Towers, P.O. Box 5003310
Dubai, United Arab Emirates
Ph: (971) 4448-7242 - Fx: (971) 4448-7112
info@evapco.ae

EVAPCO Air Solutions a/s
A wholly owned subsidiary of EVAPCO, Inc.
Knøsgårdvej 115, 9440 Aabybro, Denmark
Ph: (45) 9824-4999 - Fx: (45) 9824-4990
flexcoil@flexcoil.dk

EVAPCO S.A. (Pty.) Ltd.
A licensed manufacturer of Evapco, Inc.
18 Quality Rd, Isando 1600, Rep. of S. Africa
Ph: (27) 11 392-6630 - Fx: (27) 11-392-6615
evapco@evapco.co.za

Evap Egypt Engineering Industries Co.
A licensed manufacturer of Evapco, Inc.
5 Al Nasr Road St., Nasr City, Cairo, Egypt
Ph: (20) 2-24022866 / (20) 2-24044997/8
Fx: (20) 2-404-4667/ Mob: (20) 12-3917979
primacool@link.net / shady@primacool.net

Asia/Pacific

**EVAPCO China
Asia/Pacific Headquarters**
1159 Luoning Rd. Baoshan Industrial Zone
Shanghai, P. R. China, Postal Code: 200949
Ph: (86) 21-6687-7786 - Fx: (86) 21-6687-7008
marketing@evapcochina.com

**Evapco (Shanghai) Refrigeration
Equipment Co., Ltd.**
1159 Luoning Rd., Baoshan Industrial Zone
Shanghai, P.R. China, Postal Code: 200949
Ph: (86) 21-6687-7786 - Fx: (86) 21-6687-7008
marketing@evapcochina.com

**Beijing EVAPCO Refrigeration
Equipment Co., Ltd.**
Yan Qi Industrial Development District
Huai Rou County
Beijing, P.R. China, Postal Code: 101407
Ph: (86) 10 6166-7238 - Fx: (86) 10 6166-7395
evapcoobj@evapcochina.com

EVAPCO Australia Pty Ltd.
34-42 Melbourne Road - P.O. Box 436
Riverstone, N.S.W. Australia 2765
Ph: (61) 29 627-3322 - Fx: (61) 29 627-1715
sales@evapco.com.au

EvapTech Composites Sdn. Bhd
No. 70 (Lot 1289) Jalan Industri 2/3
Rawang Integrated Industrial Park
Rawang, Selangor, 48000 Malaysia
Ph: 60 3 6092-2209 - Fx: 60 3 6092-2210

EvapTech Asia Pacific Sdn. Bhd
A wholly owned subsidiary of EvapTech, Inc.
IOI Business Park, 2/F Unit 20
Persiaran Puchong Jaya Selatan
Bandar Puchong Jaya,
47170 Puchong, Selangor, Malaysia
Ph: +(60-3) 8070 7255 - Fx: +(60-3) 8070 5731
marketing-ap@evaptech.com



EVAPCO... Specialists in Heat Transfer Products and Services.
Visit EVAPCO's Websites at: www.evapco.eu / www.mrgoodtower.eu

