

CLOSED CIRCUIT COOLERS

eco-Air™ Series

environmentally
Conscious
Operation

Providing Maximum Water Savings



EAW-VS

EAW-VA

EAW-FD



for LIFE



EAW-Models
† Mark owned by the Cooling
Technology Institute



EVAPCO is more than a name.

It's a pledge to make everyday life easier, more comfortable, more reliable, and more sustainable for people everywhere. How do we fulfill that promise? It's simple.

We never stop innovating.

At EVAPCO, we don't just talk about innovation, it's ingrained in our workflow. Guided by our annually developed R&D plans, we set out to find groundbreaking solutions that transform the way the world works for the better. It's why we have more than 78 active patents worldwide.

We craft exceptionally built solutions.

As an employee-owned company, we take pride in our work. We are proud to be one of the most experienced teams of engineers and craftsmen in the industry. This translates into solutions that are always exceptionally built. EVAPCO has an unwavering commitment to provide "best in class" heat transfer solutions and services.

We guarantee performance.

Every EVAPCO solution is put through rigorous research and testing to ensure maximum efficiency and reliability. But we don't stop there. EVAPCO is an industry leader in independent, third-party performance certifications. These certifications guarantee our performance metrics—so that you can plan your projects with complete peace of mind.

We protect the environment.

Innovation and environmental sustainability go hand-in-hand at EVAPCO. Our industrial heat transfer equipment not only conserves natural resources and helps reduce noise pollution, but also features recycled steel content in construction. EVAPCO's stainless steel units are constructed of panels that contain up to 75% of recycled content, and our galvanized units contain over 80%. From sound reduction to water conservation to chemical elimination, we are continuously developing new technologies that deliver the ultimate operating advantages to our clients—while protecting the planet for every generation to come.

Get to Know EVAPCO

- The global innovator in heat transfer solutions
- Serving the commercial HVAC, Industrial Refrigeration, Power Generation, and Industrial Processing markets
- Founded in 1976
- Employee-owned
- 26 engineering & manufacturing facilities in 14 countries
- More than 200 sales offices worldwide

Learn More Now

Visit evapco.eu to download product catalogs, view complete product specifications, and more.



FULL SPECTRUM GLOBAL SOLUTIONS



EVAPCO provides a full spectrum of global product solutions for the Commercial HVAC, Process Cooling, Industrial Refrigeration and Power Generation markets.

From the smallest factory assembled cooling tower to the largest field erected air-cooled steam condenser, we offer heat transfer products designed to meet the water and energy requirements for any project. We are committed to providing solutions that are energy efficient and conserve water.

Certified Performance

EVAPCO's eco-Air Series of dry coolers is now CTI certified for thermal performance per Standard 201. The Cooling Technology Institute (CTI) is an independent third-party organization who validates the thermal performance of evaporative and dry heat rejection equipment. CTI Standard 201 was expanded to include dry coolers in 2022. CTI certification provides credibility to EVAPCO's published thermal performance ratings, ensuring every customer has peace of mind when purchasing EVAPCO products.



The eco-Air Series completes our successful eco-family of closed circuit coolers and condensers with water-saving dry and hybrid technology.

As an industry leader in independent, third-party performance certifications, our fully-rated products enable you to operate your cooling systems efficiently and with complete peace of mind.

The eco-Air Series coolers offers unparalleled flexibility in a wide range of capacities, footprints, motor types, and control options.



EC Motor Option



AC Motor Option

EC & AC Motor Options Available on
Flat (EAW-FD), V Coil Dry (EAW-VD),
V Coil Adiabatic (EAW-VA) and V Coil Spray (EAW-VS) Models

eco-Air Series Design & Construction Features

Available in fully dry, adiabatic and spray designs, the eco-Air Series maximizes heat rejection with minimal or no water use. The eco-Air Series is another chapter in EVAPCO's ongoing commitment to high quality, environmentally friendly products.

Structure and Casing

- Standard Z-725 galvanized steel (725 g/m² of zinc)
- Stainless steel available for increased corrosion resistance and longevity

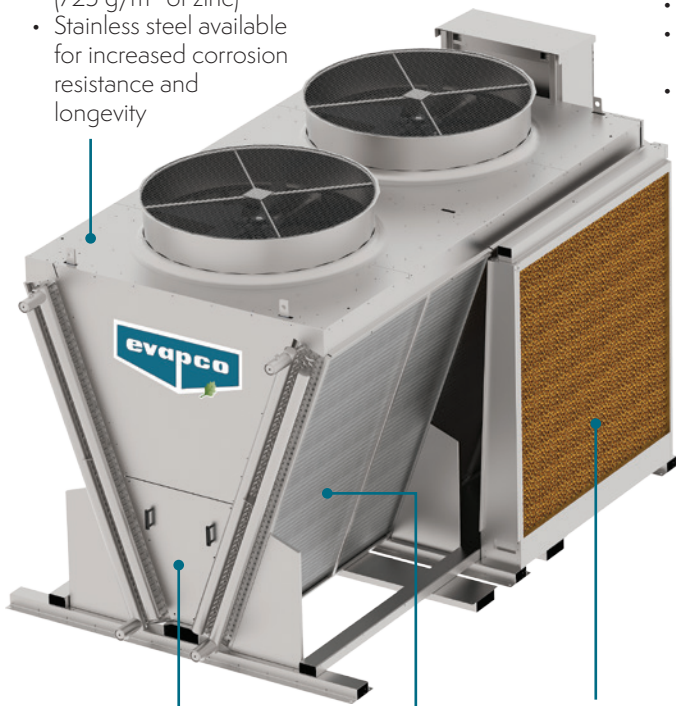

V Coil Models (EAW-VD, EAW-VA, EAW-VS)

- Maximum surface area per footprint
- Optimized coil angle for heat rejection and air flow
- Compact plan area and layout

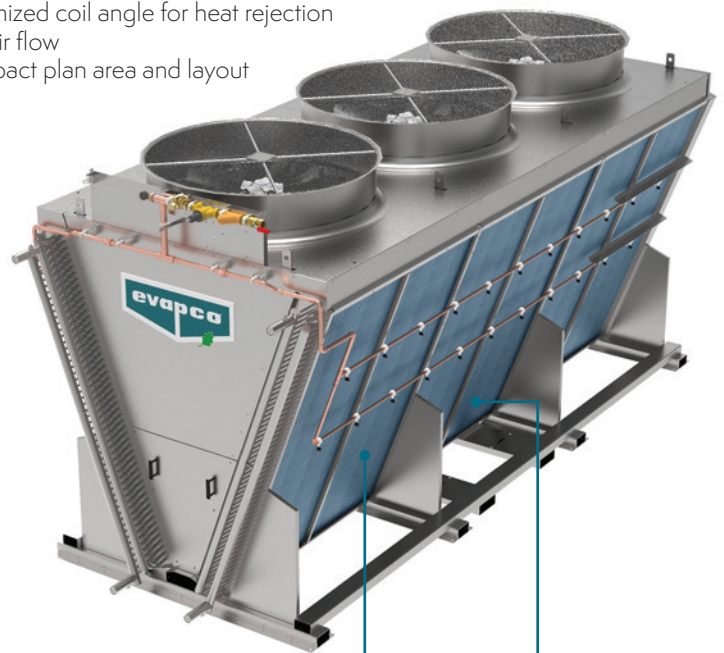

Inspection Panel (V Coil Models)

- Easily removable for interior inspection and access to coils and fan motors



Heat Exchanger Coils

- Copper tubes with aluminum fins
- Stainless steel tubes with aluminum fins available
- Multiple fin spacings and tube configurations
- Upgraded fin thickness available
- Coated aluminum fins available for increased corrosion resistance with no impact on unit performance

Adiabatic Pre-Cooling System (Optional)

- Wetted pads can be utilized to pre-cool entering air, resulting in greater energy savings, and increased capacity, with minimal water use
- Great for high dry bulb climates and high temperature applications
- Once through design
- No water treatment required
- No cold water basin or pump
- No drift
- V coil models only

Spray Assist System (Optional)

- Peak load cooling solution
- Coated fins
- Tangential-flow hollow cone nozzles
- Self-draining copper piping

Coated Fins

- Standard on Spray Models
- Optional on Dry & Adiabatic Models
- Increased corrosion resistance
- No impact on unit capacity

Coil Return Bend Covers

- Protects the coil return bends during handling and operation



Internal Step Deck (Optional-V Coil Models)

- Platform and grab rail for access to elevated fan section components (2.4 m wide V Coil Models only)

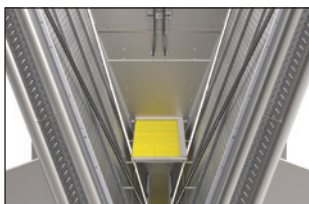

eco-Air Series Design & Construction Features

Advanced Motor Technology – Electronically Commutated (EC) or AC fan motor designs



EC

- High Efficiency
- Zero Maintenance
- Integral Speed Control
- Inherently Low Sound



AC

- Premium efficient direct drive
- Zero maintenance permanently sealed bearings
- VFD ready
- Severe Duty

Flat Coil Models (EAW-FD)

- Low profile design
- Great for elevated installations with bottom airflow clearance

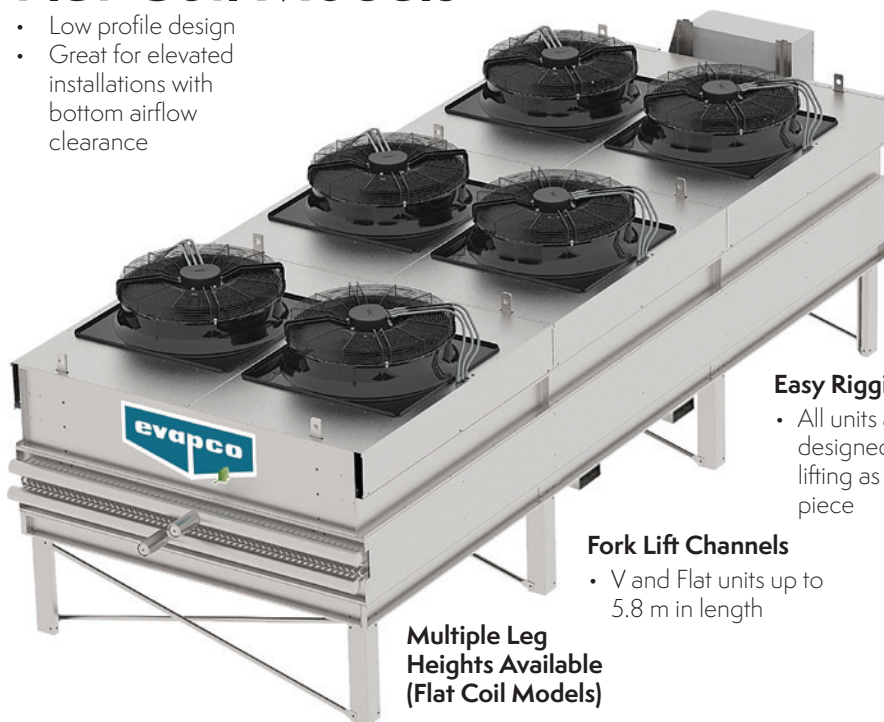

Easy Rigging

- All units are designed for lifting as once piece

Fork Lift Channels

- V and Flat units up to 5.8 m in length

Multiple Leg Heights Available (Flat Coil Models)

Common Terminal Box

- All motors factory wired
- Saves time in the field



Factory Mounted & Wired Controls

- EVAPCO PLC Panel (EC Motors)
- EVAPCO PLC/VFD Panel (AC Motors)
- Single point power connection



IBC Compliant Design

- All standard models meet IBC requirements
- Upgraded designs available for high seismic and wind load areas
- Shake table verified for 1.5 Importance Factor installations

Warranty

- 2 years complete unit
- 2 years adiabatic pads (if equipped)
- 2 years spray system (if equipped)
- 2 year EVAPCO Controller and other electrical components (if equipped)



eco-Air Series Dry Cooler
Thermal Performance is CTI certified per STD-201.

† Mark owned by the Cooling Technology Institute

Dry Principles of Operation

eco-Air Series V Coil (EAW-VD) & Flat Coil (EAW-FD) Dry Cooler

Hot Process fluid enters the inlet header connection, shown in red. Heat from the fluid dissipates through the coil tubes surface and out to the fins. Ambient air is drawn in over the coil surface by the fan located at the top of the unit. Heat from the process fluid transfers to the air and discharges to the atmosphere. Cool process fluid exits the unit through the connections shown in blue.

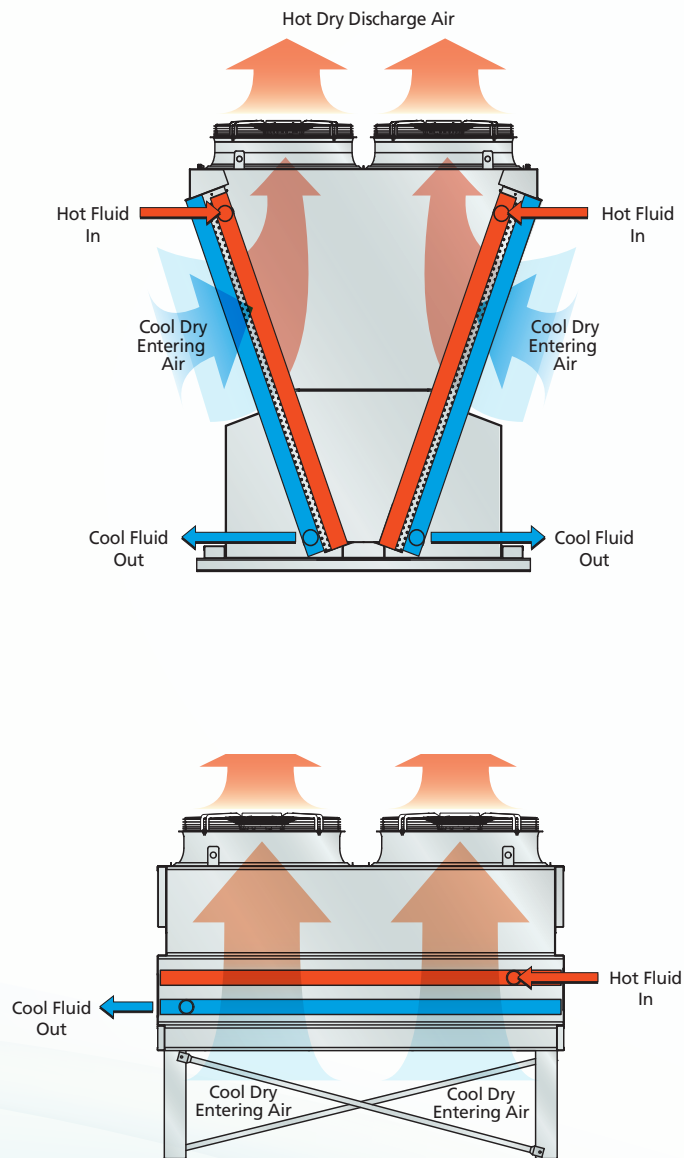

Adiabatic & Spray Principles of Operation

eco-Air Series V Coil (EAW-VA) Adiabatic Cooler

Hot process fluid enters the inlet header connection, shown in red. Heat from the process fluid dissipates through the coil tubes surface and out to the fins. The adiabatic system involves fully wetting a fibrous pad located in front of the coil. Ambient air is drawn through the adiabatic pre-cooling pad by the fans located on top of the unit. The air is saturated as it passes through the adiabatic pad, decreasing the dry bulb temperature within a few degrees of the wet bulb temperature. This new air temperature is referred to as the depressed dry bulb. This pre-cooled air is then drawn through the tube and fin surface, offering a substantial increase in heat rejection capability. Heat from the process fluid transfers to the air and discharged to the atmosphere. Cool process fluid exits the unit through the connections shown in blue.

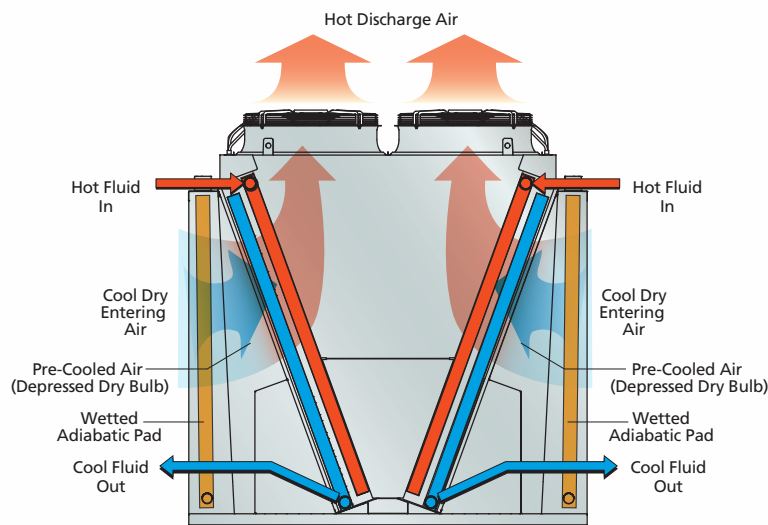

eco-Air Series V Coil (EAW-VS) Spray Cooler

Hot process fluid enters the inlet header connection, shown in red. Heat from the process fluid dissipates through the coil tubes surface and out to the fins. The unit operates completely dry and modulates fan speed as necessary based on process temperature requirements and ambient conditions. When the unit can no longer maintain leaving water temperature set point in dry mode, the spray assist system is actuated. The spray system nozzles spray water away from the coil, cooling the entering air and increasing the heat rejection capability of the unit. The heat from the process fluid transfers to the cooled air and is discharged to the atmosphere. Cool process fluid exits the unit through the connections shown in blue.

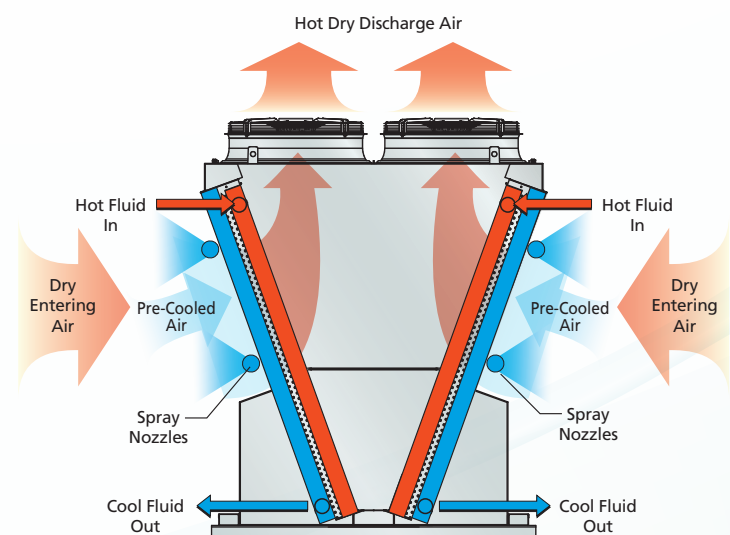

Spray System Disclaimer: Although the nozzles spray water away from the coil, the coil and structure will get wet when water is in use. Due to this, the water chemistry guidelines provided in the Installation and Operation Manual should be strictly followed along with the recommended cleaning and maintenance instructions. Evapco also recommends designing the system for a maximum of 200 hours of spray operation per year to help limit the possibility for scale build-up and corrosion.

Advanced Coil Technology

EVAPCO has long been the industry innovator in heat exchanger coil technology starting in the early 1990's with the introduction of Thermal-Pak® coils which revolutionized the industry. Soon after, EVAPCO became the benchmark in industrial evaporator design, standardizing on stainless steel tubes and aluminum fins. The eco-Air Series coil design builds upon this past success. The coil tube diameter, geometry, and circuiting have been optimized through thousands of hours of theoretical modeling and laboratory testing. The result is optimal heat transfer efficiency with low airside pressure drop and low motor watts per kilowatt.

Coil Design

Through the use of computational fluid dynamics (CFD) modeling software, finite element heat transfer analysis, and proprietary coil performance calculation methods, EVAPCO engineers have identified significant design elements to improve the finned coil performance. The extensive computer modeling has been refined and verified through coil performance evaluation in EVAPCO's state of the art research laboratories.

Superior Stainless Steel Technology (Optional)

eco-Air Series dry coolers are constructed with high-grade stainless steel tubing and aluminum fins as optional.

EVAPCO's stainless steel tubes are available in 15.65 mm OD. Coils are built in with a fin thickness of 0.18 mm and a fin spacing of 2.3 mm as standard using a full-collar aluminum fin.

For applications where corrosion of the aluminum fin is a concern, EVAPCO offers coated aluminum fins with no impact on unit performance.



Benefits of eco-Air Series

Reduced Maintenance

Scaling, corrosion, and water born bacteria concerns are minimized or eliminated with dry and adiabatic cooling equipment. The eco-Air Series reduces the maintenance traditionally associated with fully evaporative systems.

The eco-Air Series adiabatic & spray coolers are designed as a once through systems, meaning no pump and no basin to hold water, reducing the time required for maintenance. Additionally on adiabatic units, the adiabatic pads filter the air before reaching the coil, limiting the exposure of dirt and debris to the tube and fin heat transfer surface.

Both AC and EC motor options require zero routine maintenance. There are no bearings to grease, belts to adjust, or fans to pitch and balance.

Reduced or Eliminated Water Consumption

Compared to traditional evaporative systems, the eco-Air Series will either eliminate or dramatically reduce water consumption. Adiabatic & spray models only use water when the ambient conditions and load require it. Reducing water consumption also reduces the ongoing expenses related with the cooling equipment such as purchasing, treating, and disposing of water.

When the eco-Air Series adiabatic & spray models are used in conjunction with the EVAPCO controls package, water conservation is maximized based on proprietary PLC logic.

Factory Mounted and Wired Controls

The motors on the eco-Air Series are pre-wired at the factory, reducing costs associated with field wiring. As standard, all units are wired to a common terminal box. Adding the EVAPCO controls package allows for both single point power supply and complete capacity control.

Installation Made Easy

All units are designed for lifting and staging in one piece.

Fork lift channels come standard on all eco-Air Series units up to 5.8 m in length. On longer units, reference the eco-Air Series IO&M for lifting requirements from the fan deck lifting lugs.

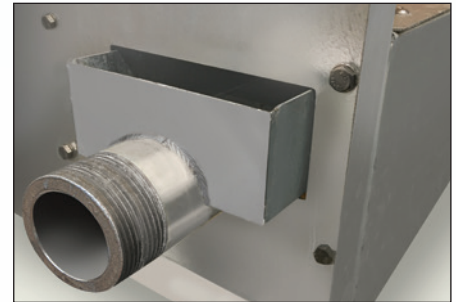

Adiabatic Pad Drip Pan



Zero Maintenance Motors



Factory Wired Fan Motors



Factory Mounted Control Panel

V Coil Configuration - EC Motor

Engineering Data

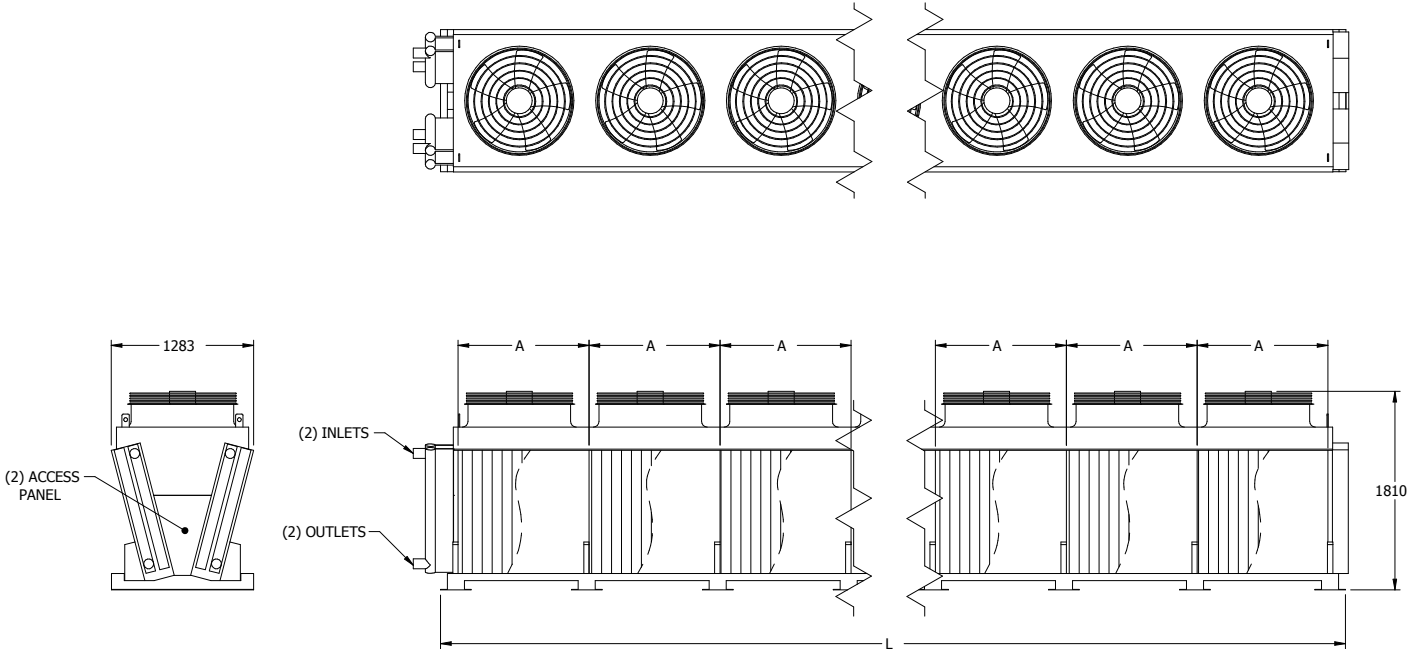

Single Fan, 4' Wide Models

Model Name	# Fans	Nominal Capacity (kW)	kW	Air Volume (m ³ /s)	Unit Length (mm)	Coil Volume (l)	Shipping Weight (kg)	Operating Weight (kg)
EAW-VD91S1MA	1	103	3.2	8.6	1505	108	535	644
EAW-VD91S2MA	2	210	6.4	17.2	2677	162	885	1048
EAW-VD91S3MA	3	315	9.6	25.7	3845	216	1211	1429
EAW-VD91S4MA	4	419	12.8	34.3	5017	270	1583	1855
EAW-VD91S5MA	5	518	16	42.9	6185	324	1919	2241
EAW-VD91S6MA	6	626	19.2	51.5	7356	378	2236	2613

Notes:

* Adiabatic width: 1781 mm

A: Two incremental fin lengths available: 1170 mm or 1300 mm

Dimensions are subject to change. Do not use for pre-fabrication.

† Nominal Capacity 40°C-35°C at 25°C dry bulb temp.

Adiabatic capacity: The adiabatic cooling effect and resulting depressed dry bulb entering the coil depends on the ambient dry bulb and associated relative humidity. Consult your sales representative, EVAPCO marketing, or Spectrum™ selection software for more information.

Spray Capacity: The cooling effect resulting from operating the spray system depends on the ambient dry bulb and associated relative humidity entering the coil. Consult your sales representative, EVAPCO marketing or Spectrum™ selection software for more information.

V Coil Configuration - EC Motor

Engineering Data

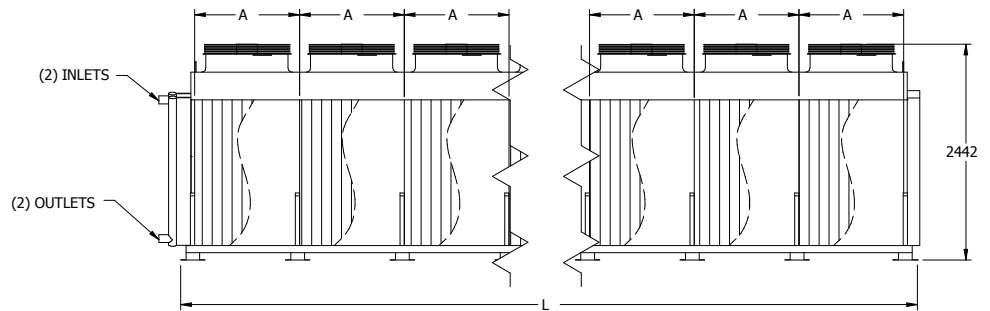
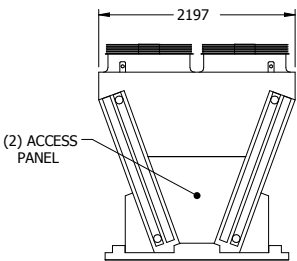
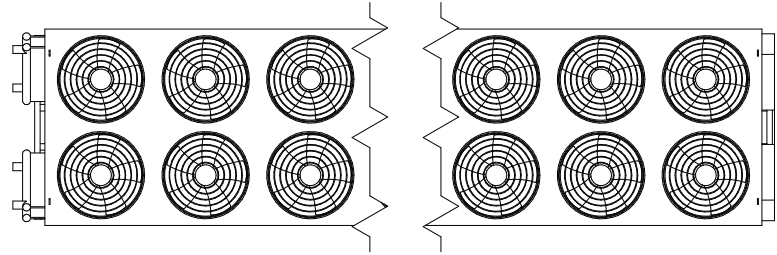

Twin Fan, 7' Wide Models

Model Name	# Fans	Nominal Capacity (kW)	kW	Air Volume (m ³ /s)	Unit Length (mm)	Coil Volume (l)	Shipping Weight (kg)	Operating Weight (kg)
EAW-VD9102PJ	2	199	6.4	15.6	1635	194	966	1161
EAW-VD9104PJ	4	409	12.8	31.2	2934	304	1597	1901
EAW-VD9106PJ	6	613	19.2	46.8	4235	413	2259	2672
EAW-VD9108PJ	8	815	25.6	62.4	5534	522	2917	3438
EAW-VD9110PJ	10	1009	32	78.1	6836	631	3506	4137
EAW-VD9112PJ	12	1218	38.4	93.7	8134	741	4150	4890
EAW-VD9114PJ	14	1374	44.8	109.3	9563	850	4794	5643
EAW-VD9116PJ	16	1580	51.2	124.9	10735	959	5443	6400
EAW-VD9118PJ	18	1787	57.6	140.5	12036	1069	6083	7149
EAW-VD9120PA	20	1872	64	149.3	12036	1178	6155	7221

Notes:

* Adiabatic width: 2683 mm

A: Two incremental fin lengths available: 1170 mm or 1300 mm

Dimensions are subject to change. Do not use for pre-fabrication.

† Nominal Capacity 40°C-35°C at 25°C dry bulb temp.

Adiabatic capacity: The adiabatic cooling effect and resulting depressed dry bulb entering the coil depends on the ambient dry bulb and associated relative humidity. Consult your sales representative, EVAPCO marketing, or Spectrum™ selection software for more information.

Spray Capacity: The cooling effect resulting from operating the spray system depends on the ambient dry bulb and associated relative humidity entering the coil. Consult your sales representative, EVAPCO marketing or Spectrum™ selection software for more information.

V Coil Configuration - EC Motor

Engineering Data

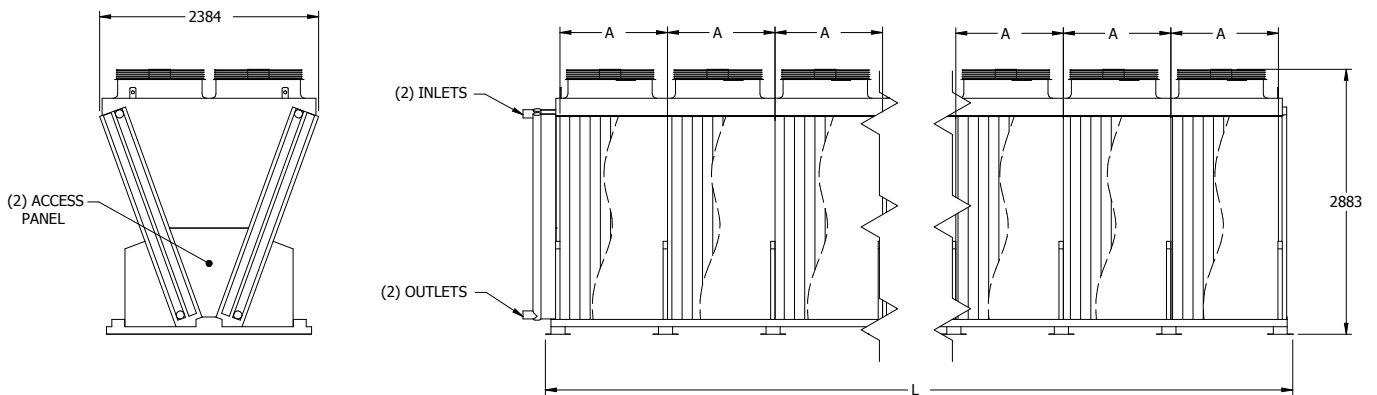
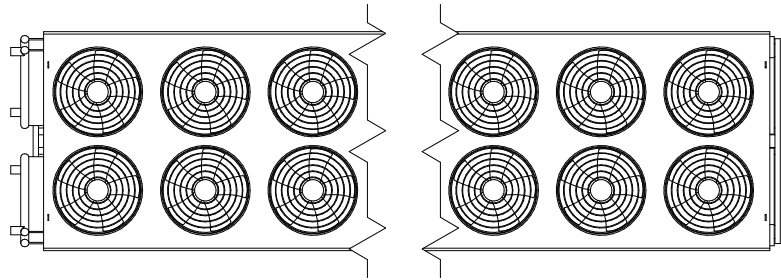

Twin Fan, 8' Wide Models

Model Name	# Fans	Nominal Capacity (kW)	kW	Air Volume (m ³ /s)	Unit Length (mm)	Coil Volume (l)	Shipping Weight (kg)	Operating Weight (kg)
EAW-VD9102ZJ	2	232	6.4	17.2	1635	260	1107	1370
EAW-VD9104ZJ	4	468	12.8	34.5	2934	407	1828	2236
EAW-VD9106ZJ	6	703	19.2	51.7	4235	554	2576	3130
EAW-VD9108ZJ	8	937	25.6	68.9	5534	700	3325	4023
EAW-VD9110ZJ	10	1159	32	86.1	6836	847	3996	4840
EAW-VD9112ZJ	12	1399	38.4	103.4	8134	993	4731	5720
EAW-VD9114ZJ	14	1638	44.8	120.6	9563	1140	5461	6595
EAW-VD9116ZJ	16	1821	51.2	137.8	10735	1286	6201	7480
EAW-VD9118ZJ	18	2059	57.6	155.1	12036	1433	6931	8355
EAW-VD9120ZA	20	2183	64	167.0	12036	1433	6954	8378

Notes:

* Adiabatic width: 2765 mm

A: Two incremental fin lengths available: 1170 mm or 1300 mm

Dimensions are subject to change. Do not use for pre-fabrication.

† Nominal Capacity 40°C-35°C at 25°C dry bulb temp.

Adiabatic capacity: The adiabatic cooling effect and resulting depressed dry bulb entering the coil depends on the ambient dry bulb and associated relative humidity. Consult your sales representative, EVAPCO marketing, or Spectrum™ selection software for more information.

Spray Capacity: The cooling effect resulting from operating the spray system depends on the ambient dry bulb and associated relative humidity entering the coil. Consult your sales representative, EVAPCO marketing or Spectrum™ selection software for more information.

V Coil Configuration - EC Motor

Engineering Data

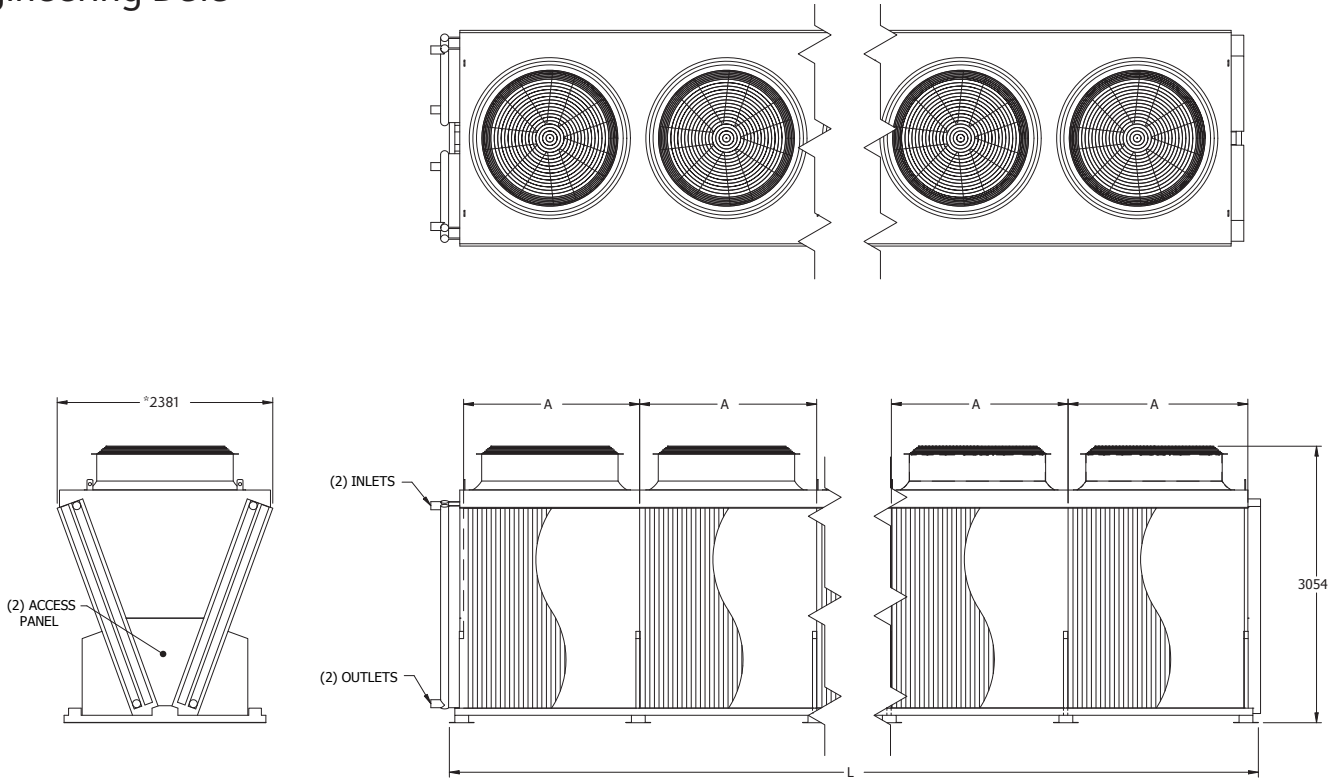

Single Fan, 8' Wide Models

Model Name	# Fans	Nominal Capacity (kW)	kW	Air Volume (m ³ /s)	Unit Length (mm)	Coil Volume (l)	Shipping Weight (kg)	Operating Weight (kg)
EAW-VD15S1ZK	1	392	17.3	29.6	2286	334	1483	1524
EAW-VD15S2ZK	2	782	34.6	59.1	4235	554	2595	2663
EAW-VD15S3ZK	3	1155	51.9	88.7	6185	773	3729	3819
EAW-VD15S4ZK	4	1554	69.2	118.2	8134	993	4758	4876
EAW-VD15S5ZK	5	1890	86.5	147.8	10084	1213	5879	6024
EAW-VD15S6ZK	6	2287	103.8	177.3	12036	1433	6985	7153

Notes:

* Adiabatic width: 2765 mm

A: One incremental fin length available: 1950 mm

Dimensions are subject to change. Do not use for pre-fabrication.

† Nominal Capacity 40°C-35°C at 25°C dry bulb temp.

Adiabatic capacity: The adiabatic cooling effect and resulting depressed dry bulb entering the coil depends on the ambient dry bulb and associated relative humidity. Consult your sales representative, EVAPCO marketing, or Spectrum™ selection software for more information.

Spray Capacity: The cooling effect resulting from operating the spray system depends on the ambient dry bulb and associated relative humidity entering the coil. Consult your sales representative, EVAPCO marketing or Spectrum™ selection software for more information.

V Coil Configuration - AC Motor

Engineering Data

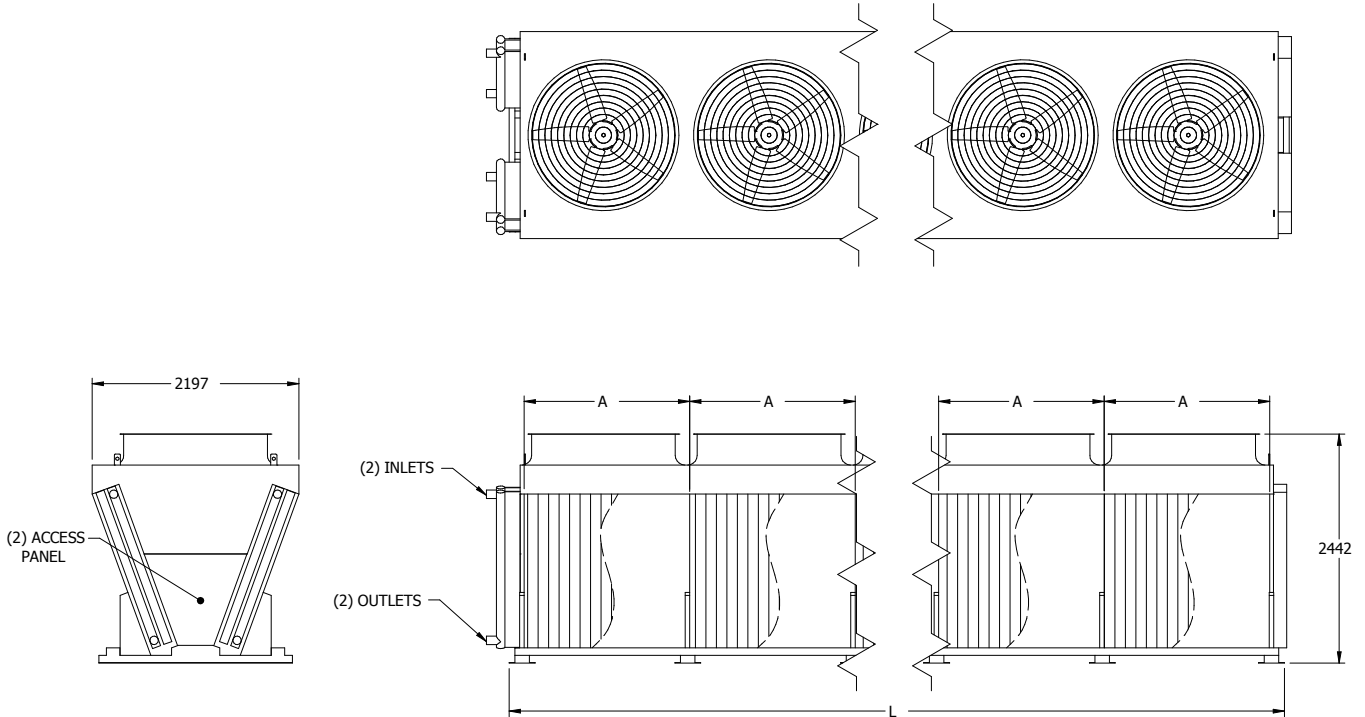

Single Fan, 7' Wide Models

Model Name	# Fans	Nominal Capacity (kW)	kW	Air Volume (m ³ /s)	Unit Length (mm)	Coil Volume (l)	Shipping Weight (kg)	Operating Weight (kg)
EAW-VD15S1PI	1	283	7.5	20.3	2677	282	1501	1783
EAW-VD15S2PI	2	570	15	40.6	5017	478	2681	3157
EAW-VD15S3PI	3	845	22.5	61.0	7356	675	3801	4472
EAW-VD15S4PI	4	1135	30	81.3	9696	872	4962	5829
EAW-VD15S5PI	5	1385	37.5	101.6	12036	1069	6142	7208
EAW-VD15S6PK	6	1516	45	113.8	12036	1069	6260	7326

Notes:

* Adiabatic width: 2683 mm

A: Three incremental fin lengths available: 1755 mm, 1950 mm or 2340 mm

Dimensions are subject to change. Do not use for pre-fabrication.

† Nominal Capacity 40°C-35°C at 25°C dry bulb temp.

Adiabatic capacity: The adiabatic cooling effect and resulting depressed dry bulb entering the coil depends on the ambient dry bulb and associated relative humidity. Consult your sales representative, EVAPCO marketing, or Spectrum™ selection software for more information.

Spray Capacity: The cooling effect resulting from operating the spray system depends on the ambient dry bulb and associated relative humidity entering the coil. Consult your sales representative, EVAPCO marketing or Spectrum™ selection software for more information.

V Coil Configuration - AC Motor

Engineering Data

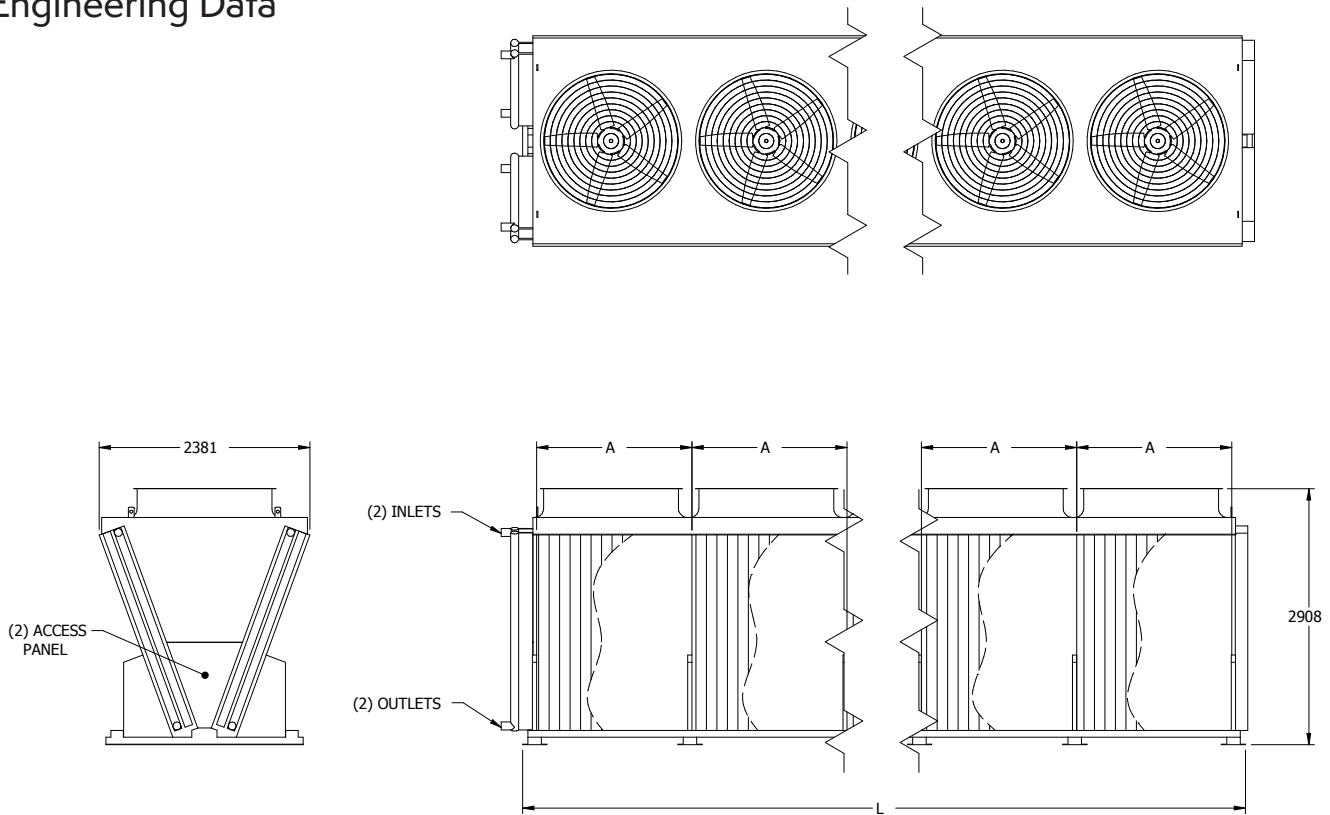

Single Fan, 8' Wide Models

Model Name	# Fans	Nominal Capacity (kW)	kW	Air Volume (m ³ /s)	Unit Length (mm)	Coil Volume (l)	Shipping Weight (kg)	Operating Weight (kg)
EAW-VD15S1ZK	1	298	7.5	21.1	2286	334	1497	1833
EAW-VD15S2ZK	2	595	15	42.1	4235	554	2626	3180
EAW-VD15S3ZK	3	896	22.5	63.2	6185	773	3774	4545
EAW-VD15S4ZK	4	1184	30	84.2	8134	993	4822	5811
EAW-VD15S5ZK	5	1489	37.5	105.3	10084	1213	5960	7167
EAW-VD15S6ZK	6	1747	45	126.4	12036	1433	7085	8509

Notes:

* Adiabatic width: 2765 mm

A: Two incremental fin lengths available: 1755 mm, 1950 mm or 2340 mm

Dimensions are subject to change. Do not use for pre-fabrication.

† Nominal Capacity 40°C-35°C at 25°C dry bulb temp.

Adiabatic capacity: The adiabatic cooling effect and resulting depressed dry bulb entering the coil depends on the ambient dry bulb and associated relative humidity. Consult your sales representative, EVAPCO marketing, or Spectrum™ selection software for more information.

Spray Capacity: The cooling effect resulting from operating the spray system depends on the ambient dry bulb and associated relative humidity entering the coil. Consult your sales representative, EVAPCO marketing or Spectrum™ selection software for more information.

V Coil Configuration - EC Motor

Engineering Data

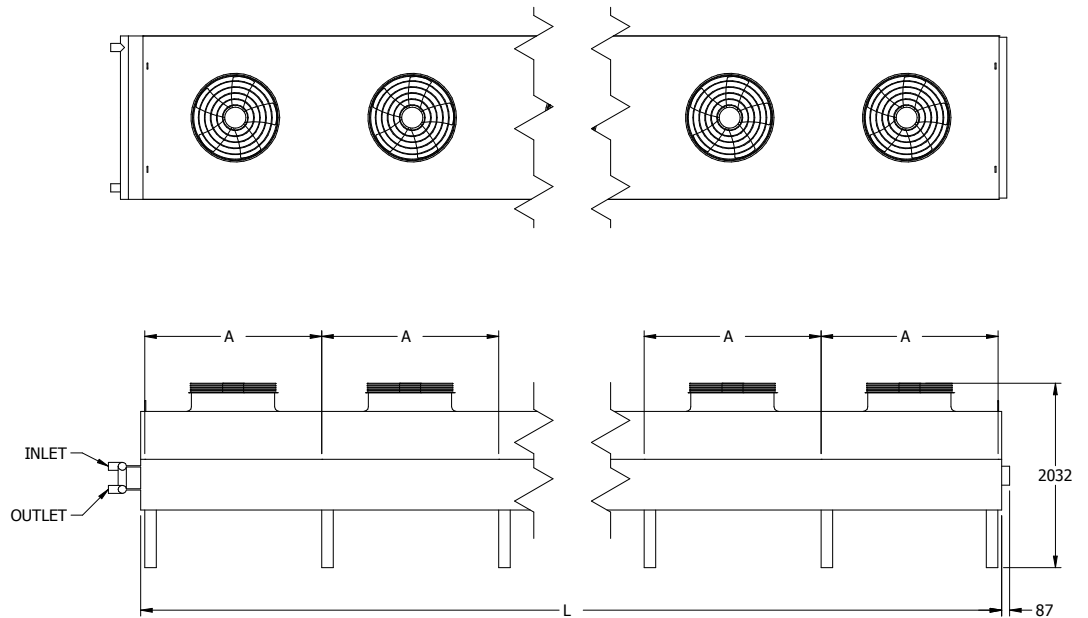

Single Fan, 6' Wide Models

Model Name	# Fans	Nominal Capacity (kW)	kW	Air Volume (m ³ /s)	Unit Length (mm)	Coil Volume (l)	Shipping Weight (kg)	Operating Weight (kg)
EAW-FD91S1WK	1	122	3.2	9	2036	124	649	776
EAW-FD91S2WK	2	246	6.4	18	3988	206	1143	1352
EAW-FD91S3WK	3	369	9.6	27	5935	288	1619	1910
EAW-FD91S4WK	4	489	12.8	35	7887	370	2018	2390
EAW-FD91S5WK	5	594	16	44	10154	452	2486	2939
EAW-FD91S6WK	6	718	19.2	53	11786	534	2957	3493

Notes:

Dimensions are subject to change. Do not use for pre-fabrication.

† Nominal Capacity based on 40°C-35°C at 25°C dry bulb temperature.

V Coil Configuration - AC Motor

Engineering Data

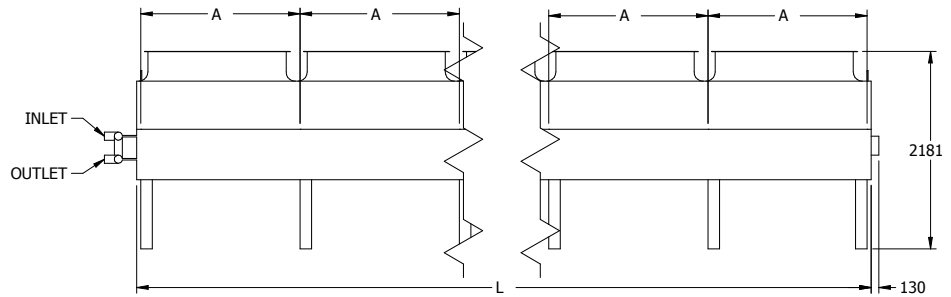
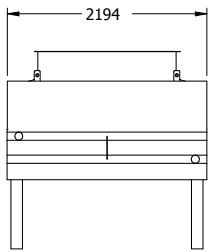
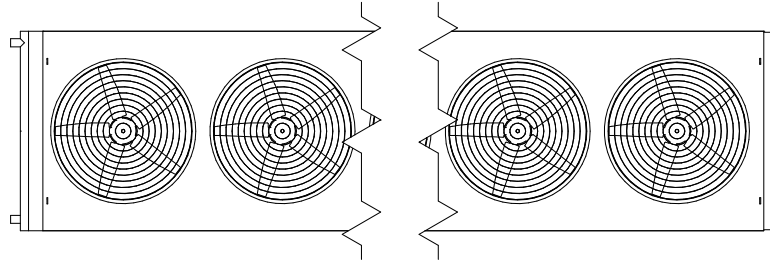

Single Fan, 7' Wide Models

Model Name	# Fans	Nominal Capacity (kW)	kW	Air Volume (m ³ /s)	Unit Length (mm)	Coil Volume (l)	Shipping Weight (kg)	Operating Weight (kg)
EAW-FD15S1PB	1	170	7.5	13	1842	137	880	1021
EAW-FD15S2PB	2	342	15	27	3596	225	1538	1764
EAW-FD15S3PB	3	504	22.5	40	5351	312	2195	2508
EAW-FD15S4PB	4	680	30	53	7106	399	2762	3162
EAW-FD15S5PB	5	823	37.5	67	8934	486	3416	3901

Notes:

A: Three incremental fin lengths available: 1755 mm, 1950 mm or 2340 mm

Dimensions are subject to change. Do not use for pre-fabrication.

† Nominal Capacity based on 40°C-35°C at 25°C dry bulb temperature.

V Coil Configuration - AC Motor

Engineering Data

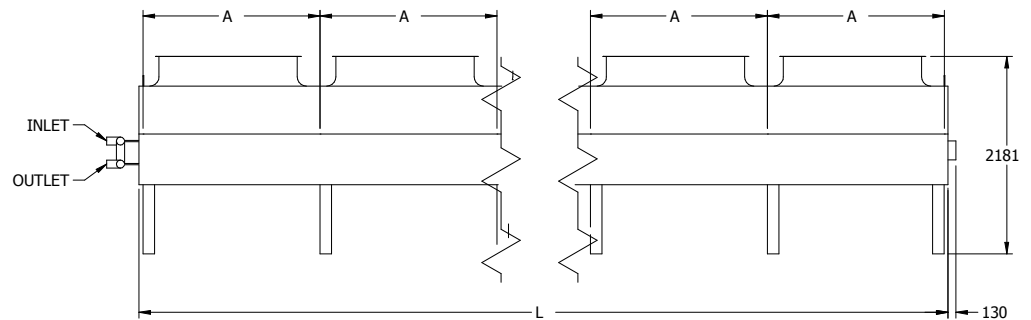
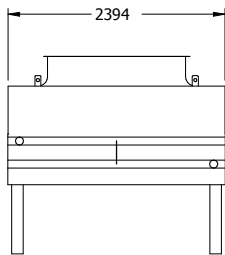
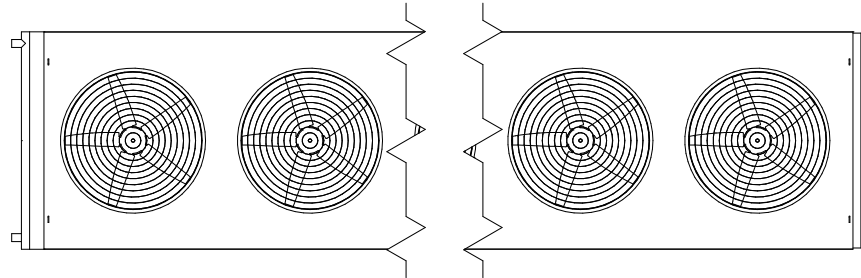

Single Fan, 8' Wide Models

Model Name	# Fans	Nominal Capacity (kW)	kW	Air Volume (m ³ /s)	Unit Length (mm)	Coil Volume (l)	Shipping Weight (kg)	Operating Weight (kg)
EAW-FD15S1ZK	1	200	7.5	15	2036	167	975	1143
EAW-FD15S2ZK	2	406	15	31	3988	277	1724	2000
EAW-FD15S3ZK	3	599	22.5	46	5935	387	2468	2853
EAW-FD15S4ZK	4	806	30	62	7887	497	3112	3606
EAW-FD15S5ZK	5	980	37.5	77	10154	607	3851	4454
EAW-FD15S6ZK	6	1185	45	93	11786	716	4586	5298

Notes:

A: Three incremental fin lengths available: 1755 mm, 1950 mm or 2340 mm

Dimensions are subject to change.

† Nominal Capacity based on 40°C-35°C at 25°C dry bulb temperature.

Wiring and Control Options

Factory wiring and control options are available for all eco-Air Series coolers. Many eco-Air Series configurations allow for single point power and factory mounted components. Please consult your sales representative or EVAPCO Marketing for job specific details.

Common Terminal Box (optional) - All motors wired to a common terminal box located on the end panel opposite coil connections.



Individual Motor Safety Switches (optional) - Mounted at each fan motor to give the user the ability to isolate individual motor power feeds.



Wiring and Control Options

EVAPCO Control Package – Operating sequence and fan speed control based on real time heat loads and ambient conditions.



- EVAPCO PLC Controller
- Supervisory control system integration
- Fan speed control:
 - EC Motor Option: Modbus control of EC fan
 - AC Motor Option: Packaged VFD fan speed control (one VFD per motor)
- Motor/VFD protection:
 - EC Motor Option: Two motors per circuit breaker
 - AC Motor Option: One motor per circuit breaker
- Operate and fault indicator lights on outside of panel
- Fluid Temperature Sensor (shipped loose)
- Ambient Temperature Sensor
- Rain/Sun Protection Hood
- Solenoid control of adiabatic pre-cooling system (if equipped)



Water supply solenoid valve arrangement

The EVAPCO Control Package is factory mounted and wired when configuration and shipping limitations allow.



Structural Steel Support

eco-Air Series Supporting Steel Dimensions		
V Models	Dry & Spray Unit Base Width (W)	Adiabatic Unit Base Width (W)
4' Wide	1270 mm	1778 mm
7' Wide	2197 mm	2680 mm
8' Wide	2229 mm	2762 mm
F Models	Base Width (W)	-
6' Wide	1710 mm	-
7' Wide	2111 mm	-
8' Wide	2311 mm	-

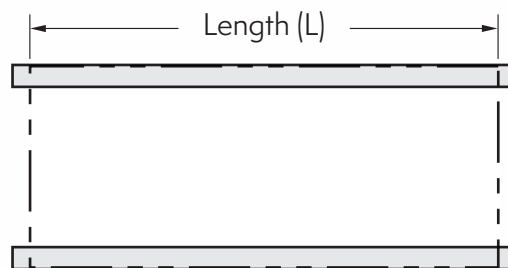
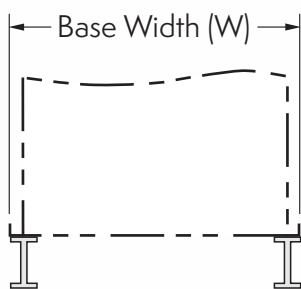

Length as shown on "unit length range (L)" in catalog table

1. These are suggested arrangements for preliminary layout purposes. Consult your EVAPCO representative for factory certified steel support drawings.
2. The recommended support for the eco-Air Series coolers is structural I-beams running the entire length of the unit. Mounting holes 19 mm in diameter are provided for bolting to the structural steel.
3. Beams should be sized in accordance with accepted structural practices. Maximum deflection of beam under unit to be 1/360 of the unit length, not to exceed 13 mm.
5. Beams should be level before setting the unit in place. Do not level the unit by shimming between it and the I-beams.
6. Support beams and Anchor bolts are to be furnished by others.
7. Dimensions, weights and data are subject to change without notice. Refer to the factory certified drawings for exact dimensions.

Staying at the forefront of technology is just as important to us as it is you. In addition to developing sustainable solutions in our state-of-the-art research facility, we've also produced analysis tools to assist you in creating a holistic view of your cooling system.

Our powerful software can optimize your design process by **calculating annualized performance data** for your location and site-specific requirements. We can provide design engineers with a comprehensive range of **water and energy consumption** data to help identify the best cooling solution for any project. You can expect the final analysis to include:

FREE COOLING POTENTIAL
WATER CONSUMPTION
COOLER POWER
CHILLER POWER
PUMP POWER
AND MORE

SPECTRUM™
by **evapco**



LEADING THE INDUSTRY WITH



RESEARCH AND DEVELOPMENT

Tour the Wilson E. Bradley Research and Development Center, one of the largest and most advanced facilities of its kind. Contact your local representative to schedule your visit today.

With our tools, expertise, and global footprint, EVAPCO can help you reach your targets wherever your next data center may be.



TECHNOLOGY

EVAPCO Technical Support Services

EVAPCO Representatives

Your EVAPCO representative is the local expert you can count on to help you with all your HVAC and industrial process needs—from getting quotes, to answering questions, to helping you manage your projects and orders. Find your local representative, by visiting evapco.eu now.

SPECTRUM™ by EVAPCO

SPECTRUM™ is a new industry leading computer selection program that makes it easy for you to find and optimize the right EVAPCO solutions for every project. Evaluate thermal performance, layout, and energy requirements across units; analyze optional equipment features; and generate complete specifications and unit drawings—all within a friendly and intuitive format. Contact your EVAPCO representative to access SPECTRUM™ now.



evapco.eu

Bookmark evapco.eu for the latest and most complete product information. The website contains a multitude of information and resources including:

- Unit certified drawings
- Steel support drawings
- Scaled isometric views in CAD
- 3-D models in Revit
- Product catalogs
- Rigging instructions
- Operation and maintenance instructions
- White papers
- Videos
- Logo apparel and merchandise

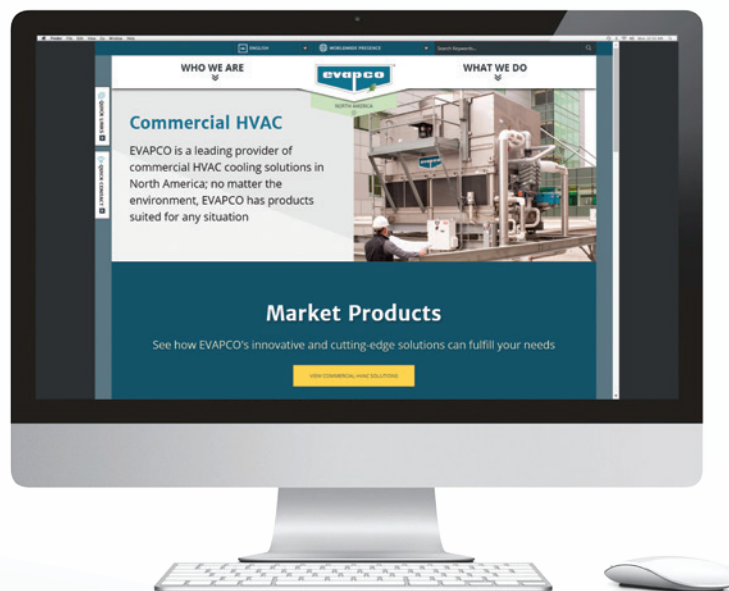



WORLDWIDE MANUFACTURING FACILITIES



- World Headquarters/ Research and Development Center
- EVAPCO Manufacturing Facilities

EVAPCO, Inc. — World Headquarters & Research / Development Center

P.O. Box 1300 • Westminster, MD 21158 USA
410.756.2600 • marketing@evapco.com • evapco.eu

North America

- EVAPCO, Inc.**
World Headquarters
Westminster, MD USA
410.756.2600
marketing@evapco.com
- EVAPCO East**
Taneytown, MD USA
- EVAPCO East**
Key Building
Taneytown, MD USA
- EVAPCO Midwest**
Greenup, IL USA
217.923.3431
evapcomw@evapcomw.com
- Evapcold Manufacturing**
Greenup, IL USA
- EVAPCO Newton**
Newton, IL USA
618.783.3433
evapcomw@evapcomw.com
- EVAPCO West**
Madera, CA USA
559.673.2207
contact@evapcowest.com
- EVAPCO Alcoil, Inc.**
York, PA USA
717.347.7500
info@evapco-alcoil.com
- EVAPCO Iowa**
Lake View, IA USA
- EVAPCO Iowa**
Sales & Engineering
Medford, MN USA
507.446.8005
evapcomn@evapcomn.com

- EVAPCO LMP ULC**
Laval, Quebec, Canada
450.629.9864
info@evapcolmp.ca
- EVAPCO Select Technologies, Inc.**
Belmont, MI USA
844.785.9506
emarketing@evapcoselect.com
- Refrigeration Vessels & Systems Corporation**
Bryan, TX USA
979.778.0095
rvs@rvscorp.com
- Tower Components, Inc.**
Ramseur, NC USA
336.824.2102
mail@towercomponentsinc.com
- EvapTech, Inc.**
Edwardsville, KS USA
913.322.5165
marketing@evaptech.com
- EVAPCO Dry Cooling, Inc.**
Bridgewater, NJ USA
908.379.2665
info@evapcodc.com
- EVAPCO Dry Cooling, Inc.**
Littleton, CO USA
908.895.3236
info@evapcodc.com
- EVAPCO Power México S. de R.L. de C.V.**
Mexico City, Mexico
(52) 55.8421.9260
info@evapcodc.com

Asia Pacific

- EVAPCO Asia Pacific Headquarters**
Baoshan Industrial Zone Shanghai, P.R. China
(86) 21.6687.7786
marketing@evapcochina.com
- EVAPCO (Shanghai) Refrigeration Equipment Co., Ltd.**
Baoshan Industrial Zone, Shanghai, P.R. China
- EVAPCO (Beijing) Refrigeration Equipment Co., Ltd.**
Huairou District, Beijing, P.R. China
(86) 10.6166.7238
marketing@evapcochina.com
- EVAPCO Air Cooling Systems (Jiangxi) Company, Ltd.**
Jiaying, Zhejiang, P.R. China
(86) 573.8311.9379
info@evapcochina.com
- EVAPCO Australia (Pty.) Ltd.**
Riverstone, NSW, Australia
(61) 02.9627.3322
sales@evapco.com.au
- EvapTech (Shanghai) Cooling Tower Co., Ltd.**
Baoshan District, Shanghai, P.R. China
Tel: (86) 21.6478.0265
- EvapTech Asia Pacific Sdn. Bhd.**
Puchong, Selangor, Malaysia
(60) 3.8070.7255
marketing-ap@evaptech.com

Europe | Middle East | Africa

- EVAPCO Europe EMENA Headquarters**
Tongerren, Belgium
(32) 12.39.50.29
info@evapco.be
- EVAPCO Europe BV**
Tongerren, Belgium
- EVAPCO Europe, S.r.l.**
Milan, Italy
(39) 02.939.9041
evapcoeuropa@evapco.it
- EVAPCO Europe, S.r.l.**
Sondrio, Italy
- EVAPCO Europe A/S**
Aabybro, Denmark
(45) 9824.4999
info@evapco.dk
- EVAPCO Europe GmbH**
Meerbusch, Germany
(49) 2159.69560
info@evapco.de
- EVAPCO Middle East DMCC**
Dubai, United Arab Emirates
(971) 56.991.6584
info@evapco.ae
- Evap Egypt Engineering Industries Co.**
A licensed manufacturer of EVAPCO, Inc.
Nasr City, Cairo, Egypt
(20) 10.054.32.198
evapco@tiba-group.com
- EVAPCO S.A. (Pty.) Ltd.**
A licensed manufacturer of EVAPCO, Inc.
Isando, South Africa
(27) 11.392.6630
evapco@evapco.co.za

South America

- EVAPCO Brasil**
Equipamentos Industriais Ltda.
Indaiatuba, São Paulo, Brazil
(55) 11.5681.2000
vendas@evapco.com.br
- FanTR Technology Resources**
Itu, São Paulo, Brazil
(55) 11.4025.1670
fantr@fantr.com